

Pre-  
cious  
De-  
sign '015

**TERZANI**  
LA LUCE PENSATA

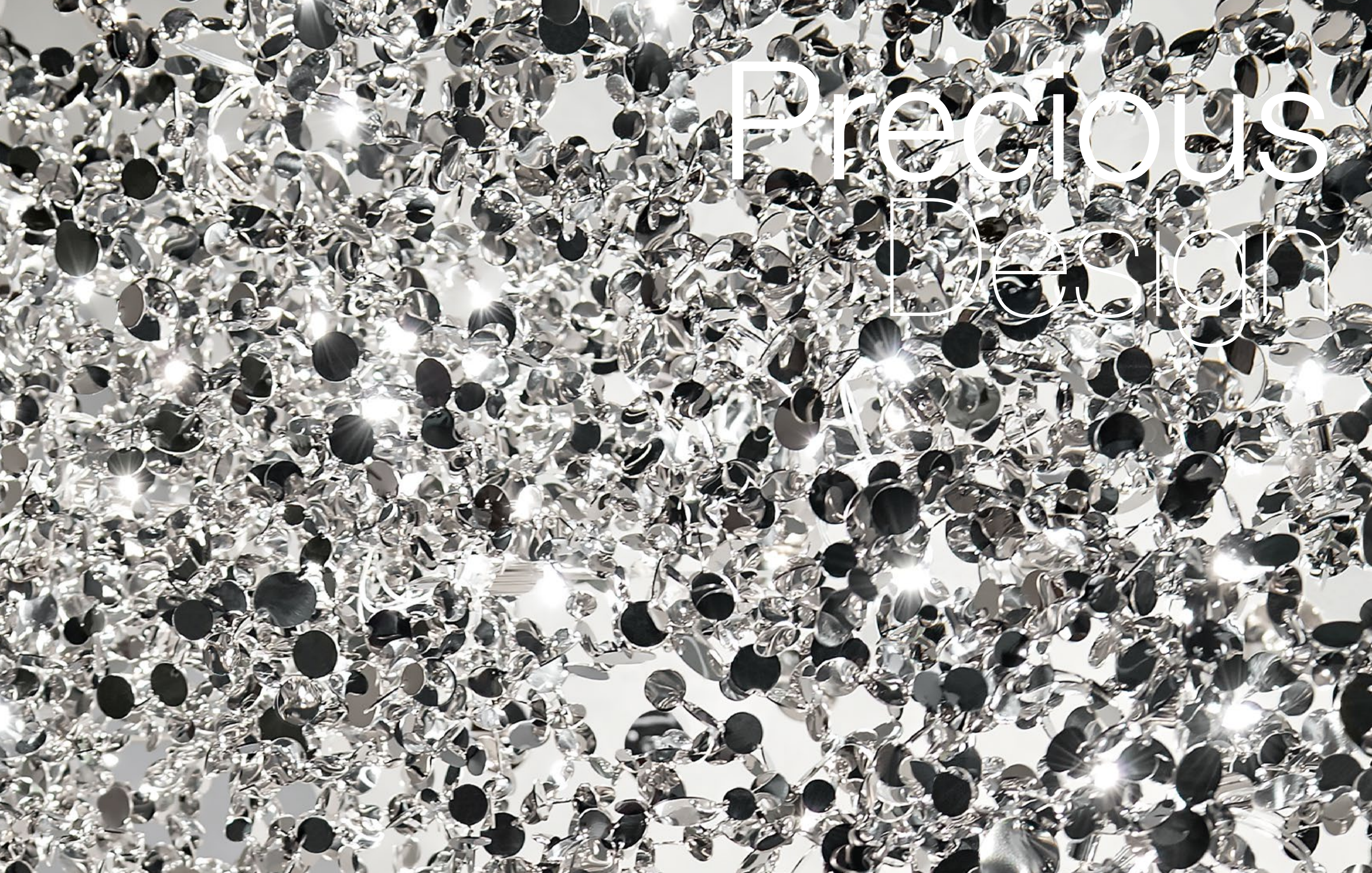



# Precious DESIGN





# Index

- 144 *Angel Falls*
- 072 *Anish*
- 096 *Argent*
- 020 *Atlantis*
- 228 *Bobino*
- 182 *Bond*
- 130 *Calle*
- 090 *Core*
- 080 *Doodle*
- 064 *Etoile*
- 150 *Frame*
- 206 *Glamour*
- 192 *G.r.a*
- 224 *Hook*
- 236 *Hugo*
- 160 *Iceberg*
- 106 *I Lucci Argentati*
- 200 *Magdalena*
- 118 *Mizu*
- 164 *Orten'zia*
- 056 *Sea Urchin*
- 140 *Shar Pei*
- 044 *Soscik*
- 034 *Stream*
- 050 *Tresor*
- 220 *Untitled*
- 010 *Volker*
- 216 *Wabi*
- 232 *Zig-Zag*









# PreciousDesign

*Terzani's Precious Design Concept is luxury evolved. Each piece in this new lighting collection breaks the staid boundaries of traditional luxury, and incorporates stunningly modern design, cutting-edge technology, artisan craftsmanship and precious materials. The result are sculptures of light whose illumination transforms spaces through dynamic lighting and shadow effects. They create a new visual language of what luxury is, one that reflects both today's aesthetics, architecture and design traditions yet also pushes towards the future.*



# Volver, Breath of new *Light.*

At Terzani, we are fortunate to work with some of the brightest young stars in Italian design. For Volver, designer Diego Bassetti and architect Andrea Panzieri of Studio 14, protégés of Bruno Rainaldi, applied their multidisciplinary approach to create Terzani's first LED suspension light. This geometric design combines thin nickel chains with the latest in LED technology to create a light that is both elegant and modern. A breath of new light, Volver melds technology and art to achieve a new level of luxury. Design Studio 14.

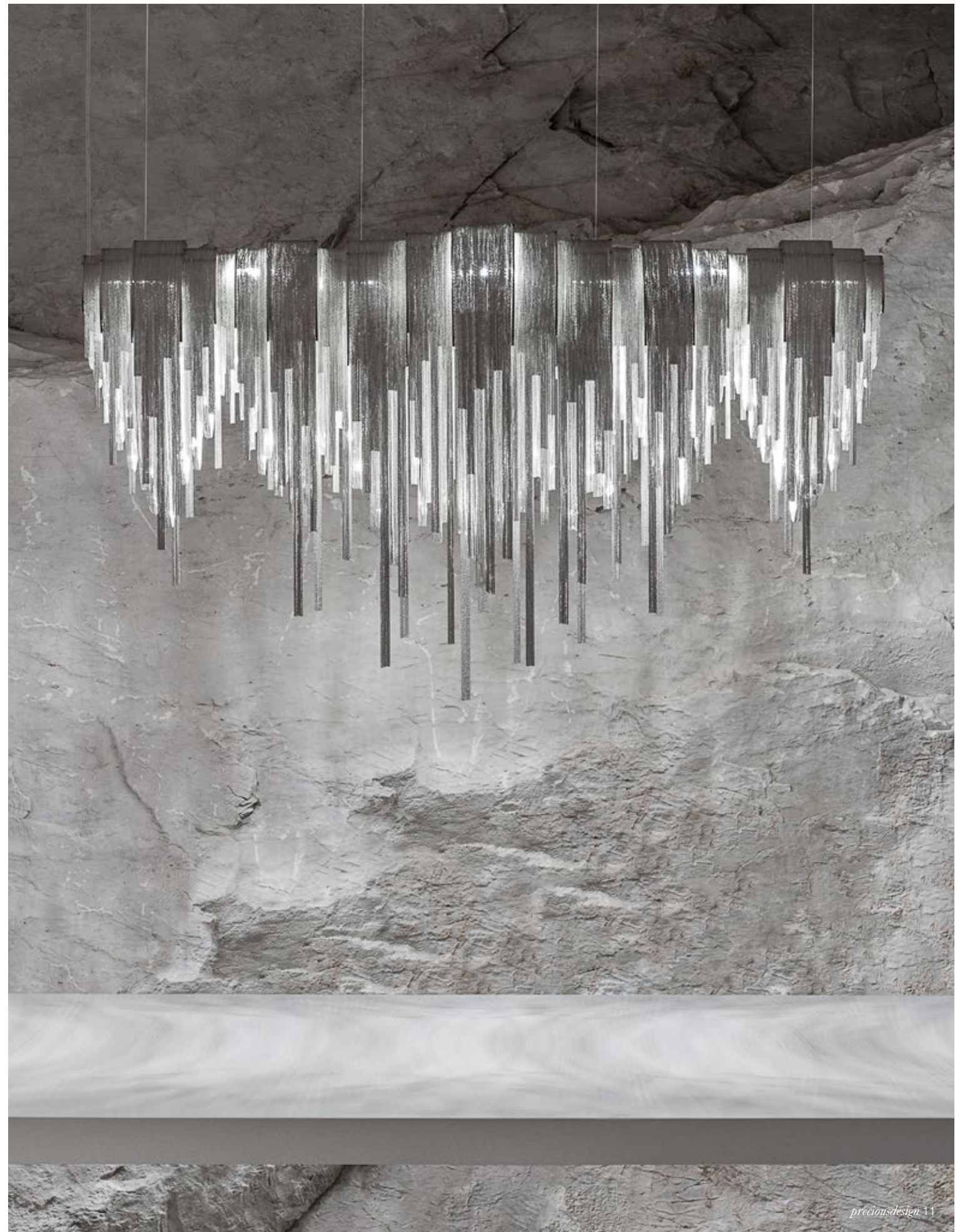















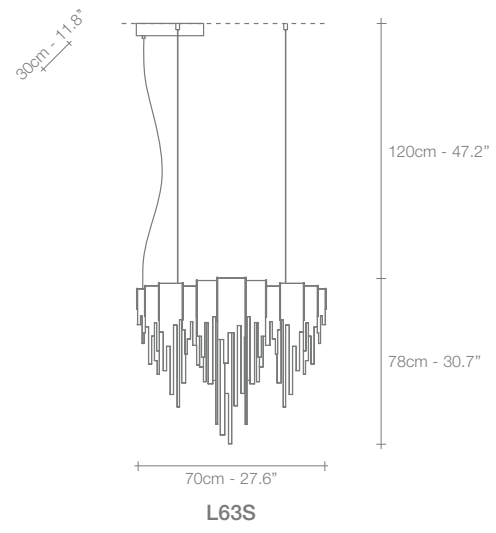
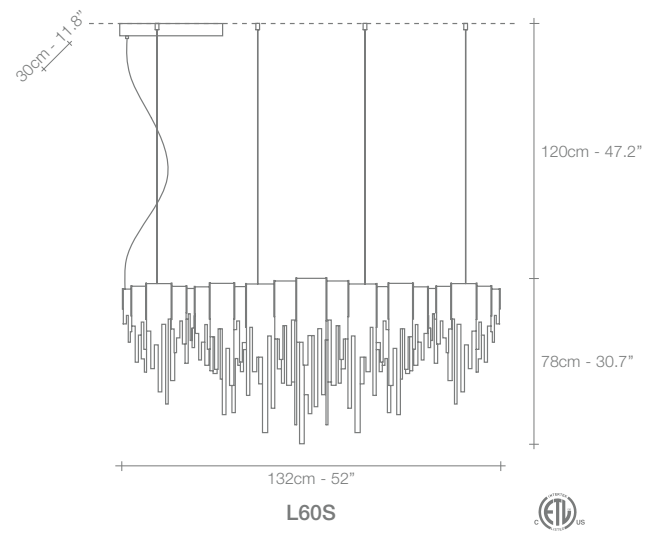
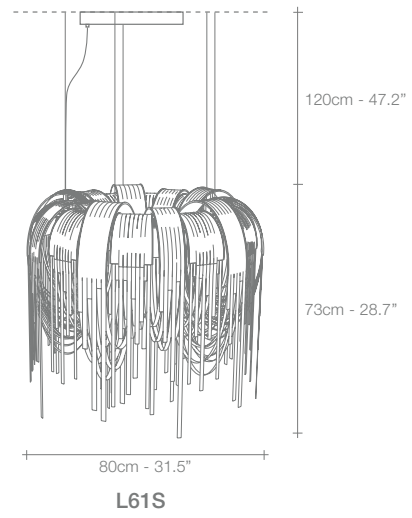
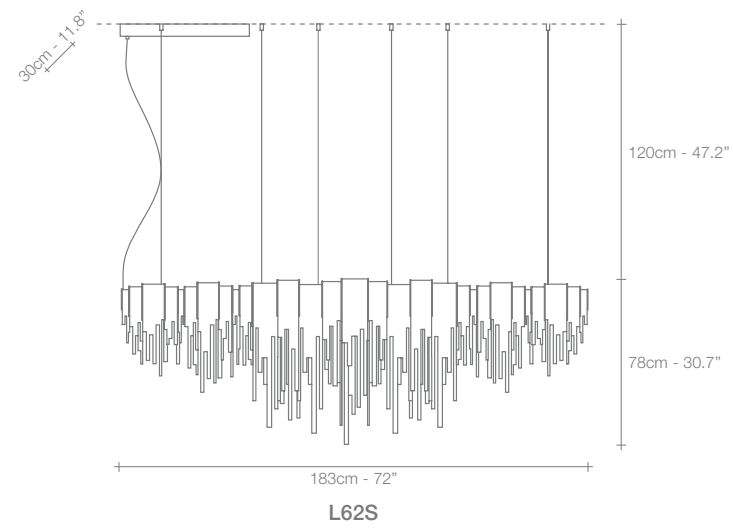

NICKEL



BLACK NICKEL



GOLD



BRONZE

230V / 120V



**L60S**   **L61S**   **L62S**   **L63S**

LED BOARD  
3000 K  
CRI 90

10X4.5W   10X4.5W   20X4.5W   7X4.5W

2700K - CRI 90  
LED BOARD  
AVAILABLE ON  
REQUEST

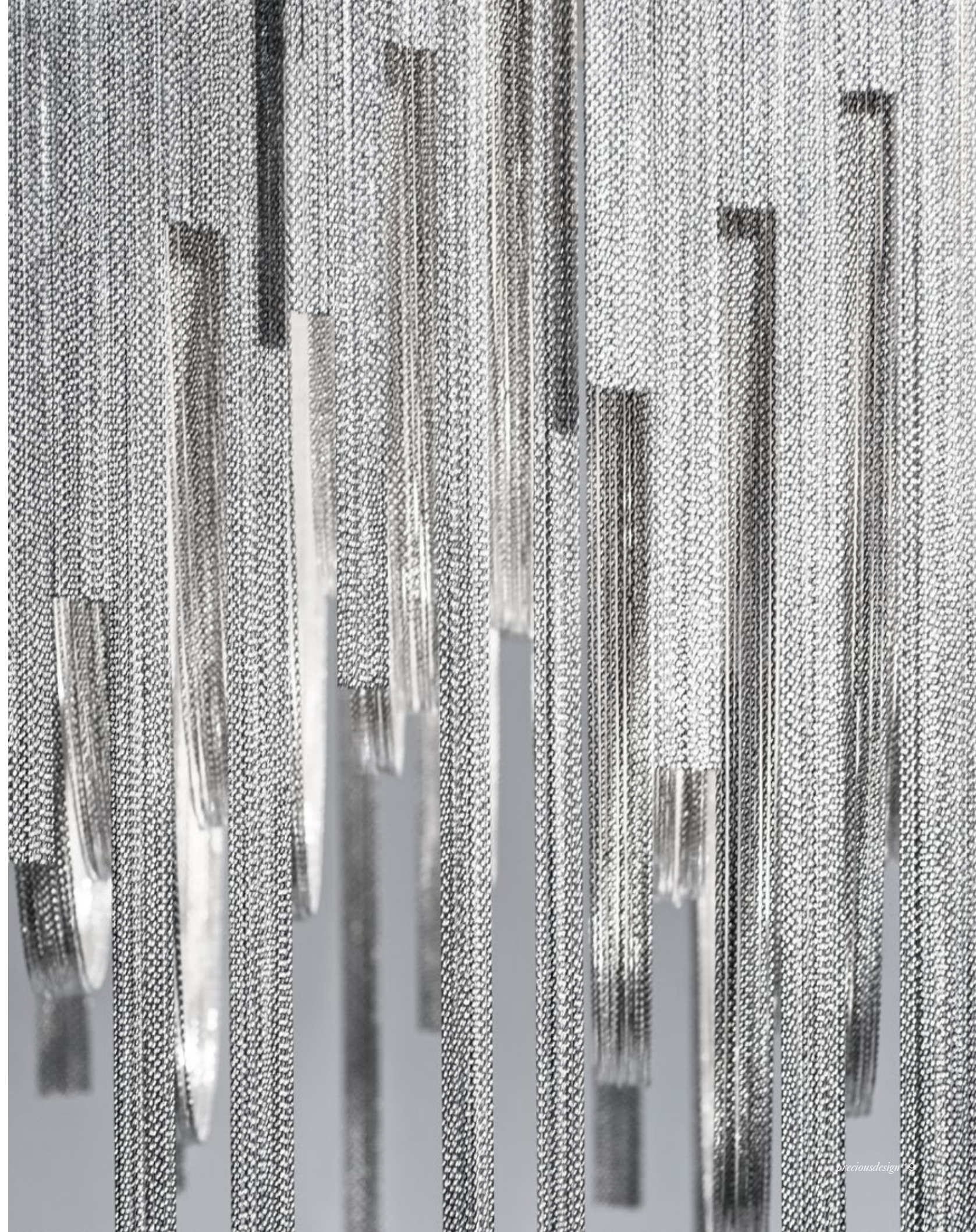



# Atlantis, a Precious *Wave.*

Seemingly alive, Atlantis shimmering light creates a vibrant source of energy. Its mesmerizing, organic effect is created by hundreds of illuminated lengths of draped, nickel chain. Like water in the ocean, Atlantis chains appear liquid, cascading over its gloss nickel bands and falling down towards the abyss before turning back into itself. Atlantis is composed of almost three miles of chain, meticulously hand-crafted by master Italian artisans. Design Barlas Baylar.

























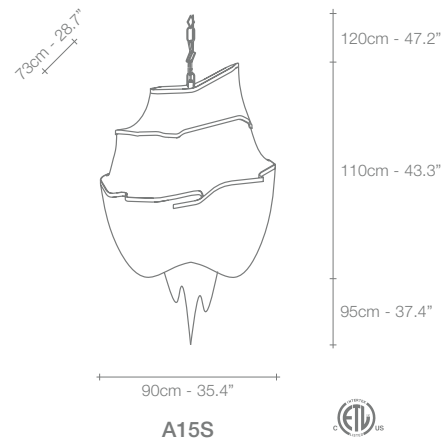

A15S

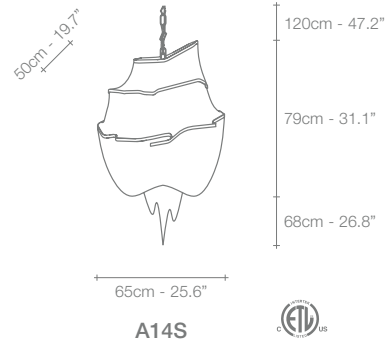

A14S

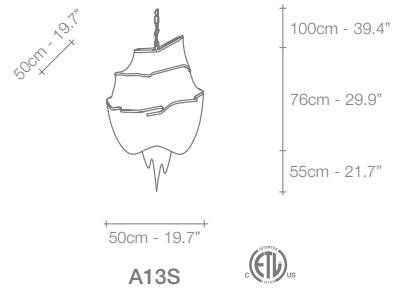

A13S

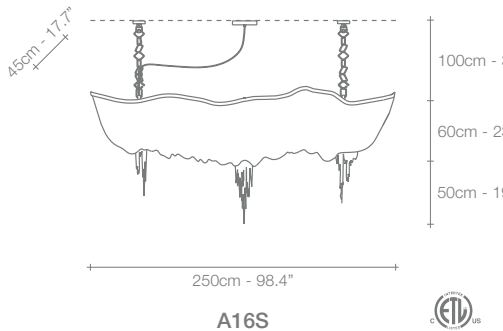

A16S

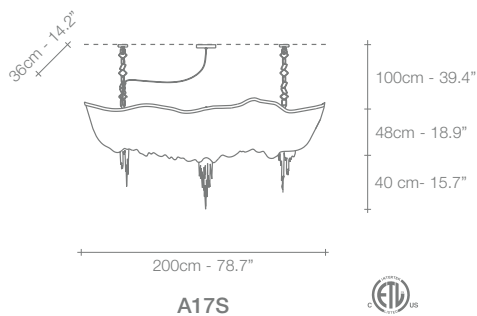

A17S

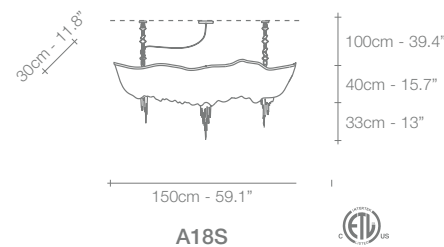

A18S

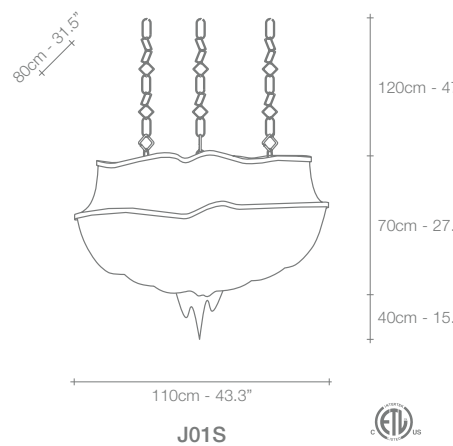

J01S

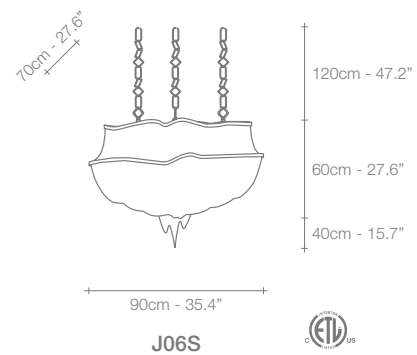

J06S

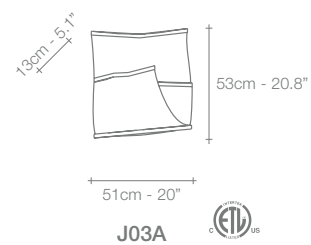

J03A

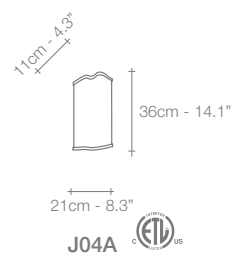

J04A



NICKEL

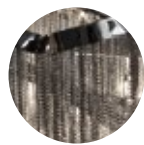

BLACK NICKEL



GOLD



BRONZE

	A13S	A14S	A15S	A16S	A17S	A18S	J01S	J03A	J04A	J06S
230V	HALOGEN ES E14	6X42W (=6x60W)	8X42W (=8x60W)	8X42W (=8x60W)	10X42W (=10x60W)	10X42W (=10x60W)	8X42W (=8x60W)	4X28W (=4x40W)	2X42W (=2x60W)	8X42W (=8x60W)
120V	FLAME CA 10 E12	6X60W	8X60W	8X60W	10X60W	10X60W	8X60W	4X40W	2X60W	8X60W

LED LIGHT BULBS MAY BE USED





# Stream, Iridescent *Light.*

A stunning design from Christian Lava, Stream is an impressive presence in any room. Stream's design exploits the physical characteristics of the materials used to envelop a room in a unique, immersive light. Here, an elegant thin metal chain appear to flow down from the undulating, nickel-plated frame. These cascading tiers project a streaking, yet tranquil, shadow throughout the room. Design Christian Lava.

















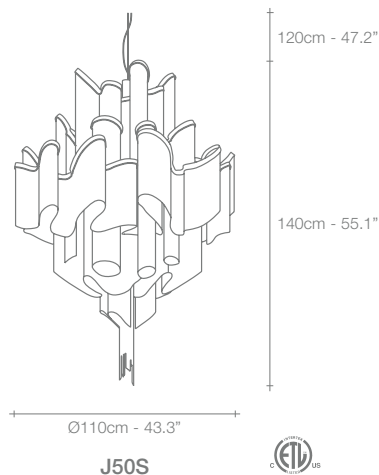

**J50S**

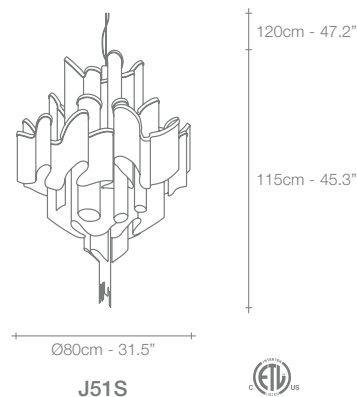

**J51S**

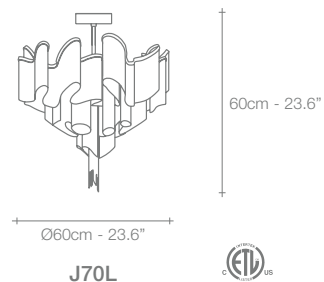

**J70L**

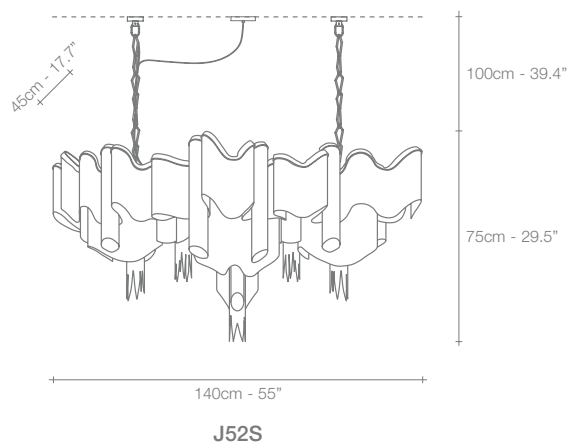

**J52S**

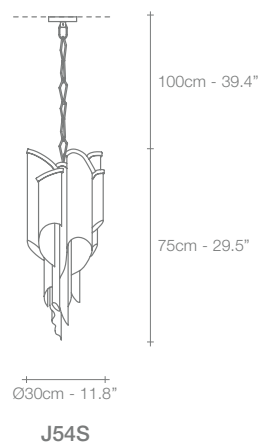

**J54S**

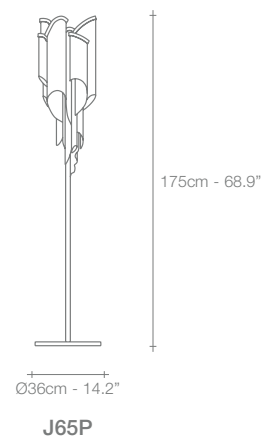

**J65P**

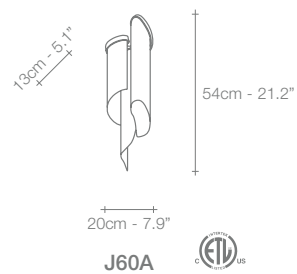

**J60A**



NICKEL

230V	HALOGEN ES E14	+	HALOGEN GU10	<b>J50S</b>	<b>J51S</b>	HALOGEN ES G9	+	HALOGEN GU10	<b>J52S</b>	<b>J54S</b>	<b>J70L</b>	HALOGEN ES E14	<b>J60A</b>	<b>J65P</b>
				20X28W E14 (=20x40W) + 35W GU10	18X28W E14 (=18x40W) + 35W GU10				12X33W G9 (=12X40W) + 3X35W GU10	4X33W G9 (=4X40W) + 35W GU10	8X33W G9 (=8X40W) + 35W GU10		2X42W (=2x60W)	6X28W (=6x40W)
120V	FLAME CA 10	+	HALOGEN MR20 GU10	20X40W E12 + 35W GU10	18X40W E12 + 35W GU10	HALOGEN JCD G9	+	HALOGEN MR20 GU10	12X35W G9 + 3X35W GU10	4X35W G9 + 35W GU10	8X35W G9 + 35W GU10	FLAME CA 10	2X60W	6X40W

LED LIGHT BULBS MAY BE USED





Soscik,  
Classic form,  
*Modern look.*

Reinventing the classics. With Soscik, Terzani combines traditional, artisan techniques with cutting edge technology to give the traditional chandelier a modern update. Over the plated frame, Soscik creates a dramatic and romantic effect, while still being able to compliment today's modern luxury. Available as a chandelier or a ceiling lamp, Soscik proves that modern design does not have to sacrifice luxury. Design Nicolas Terzani.









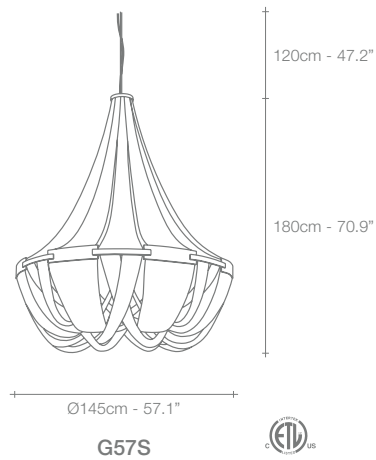

G57S

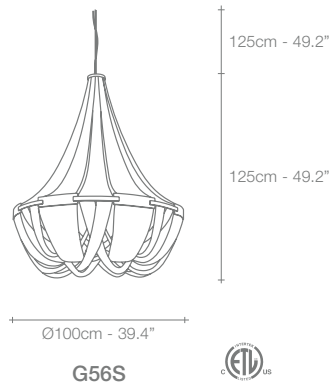

G56S

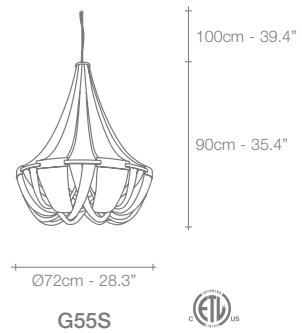

G55S

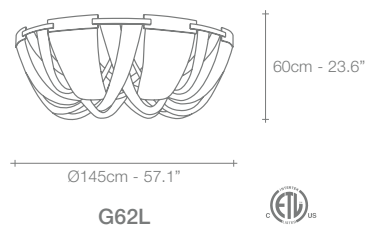

G62L

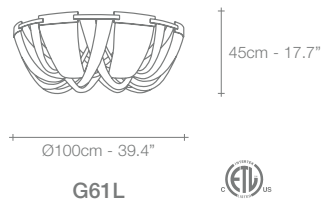

G61L

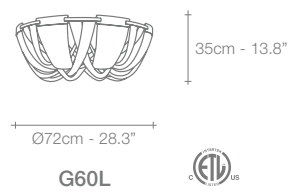

G60L



NICKEL



BRONZE

	G55S	G56S	G57S	G60L	G61L	G62L
230V	HALOGEN ES G9	8X33W (=8X40W)	12X33W (=12X40W)	14X33W (=14X40W)	8X33W (=8X40W)	10X33W (=10X40W)
120V	HALOGEN JCD G9	8X50W	12X35W	14X35W	8X35W	10X35W

LED LIGHT BULBS MAY BE USED





# Tresor, a Wealth *of Light.*

An impeccable addition to any space, Tresor's hand-made design and precious metal "coins" create scintillating halos of light. Recalling discovered treasure, the layers of gold or silver leaf create a rich, luxurious light. Available in a range of sizes, including wall sconces and pendants, Tresor has an elegance that is truly priceless. Design Jean François Crochet.









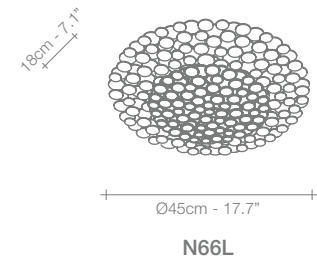
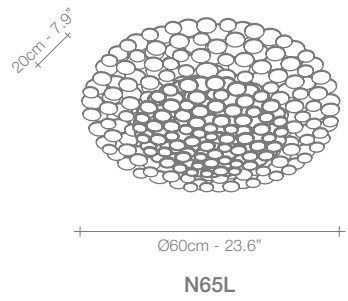
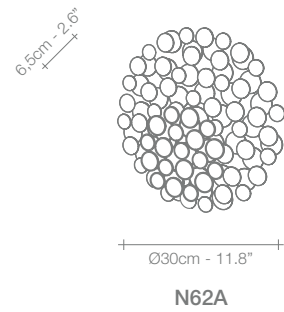
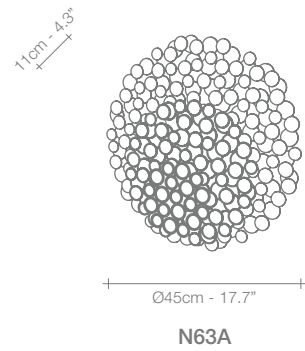
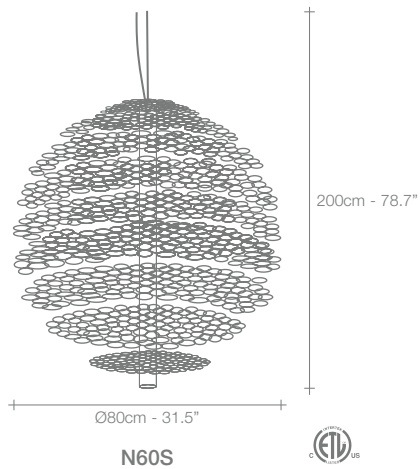

GOLD LEAF



SILVER LEAF

	N60S	N62A	N63A	N65L	N66L	
230V	HALOGEN ES G9	9X33W (=9X40W)	48W (=60W)	2X48W (=2X60W)	6X33W (=6X40W)	6X33W (=6X40W)
120V	HALOGEN JCD G9	9X35W	50W	2X50W	6X35W	6X35W

LED LIGHT BULBS MAY BE USED





# Sea Urchin, Dress your *Light.*

Pushing the boundaries of design and artistry; drawing from the haute couture designer's unique universe, sea urchin features over 1500, translucent crystal "pins" seemingly suspended around the bulb, casting a dynamic shadow around the room. The perfect accessory for your well-curated home, sea urchin is available in different finishes in both round and oblong versions. Design Maurizio Galante.













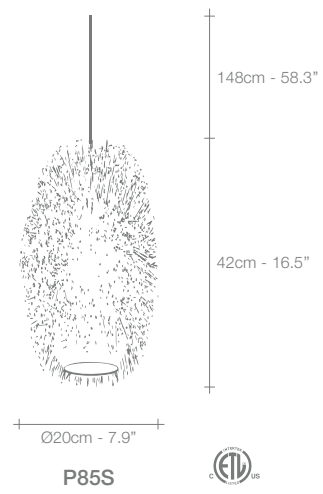
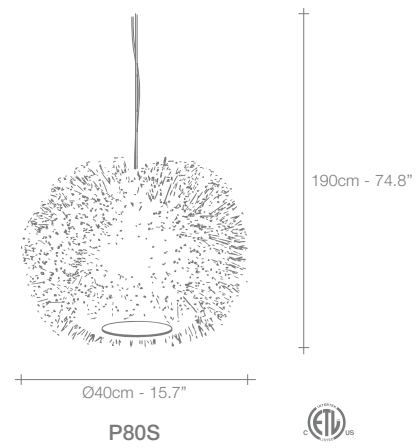
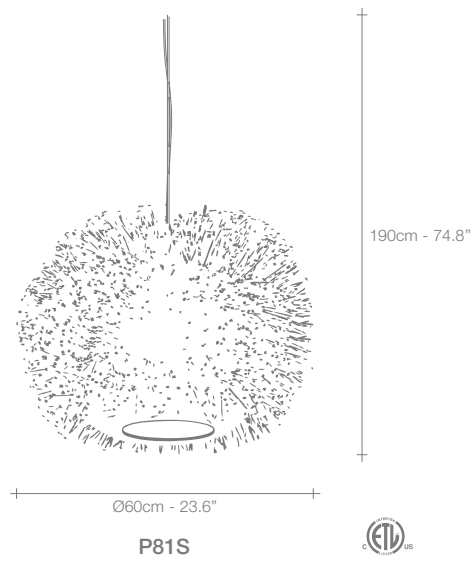

NICKEL  
SILVER  
WHITE



NICKEL  
SILVER  
SILVER



NICKEL  
SILVER  
SWAROVSKI

	P80S	P81S	P85S
230V	HALOGEN ES E27	70W (=100W)	70W (=100W)
120V	HALOGEN ECO A19 E26	72W (=100W)	72W (=100W)
			HALOGEN ES E14
			42W (=60W)
			KX-2000 T3 E12
			40W





Etoile,  
Twinkling in an  
*indoor Sky.*

Etoile's intricate network of intersecting nickel lines recalls constellations in a clear night sky. Strategically placed bulbs cast a starry light, twinkling as viewers move around the pendant. Through projecting these complex patterns throughout the room, Etoile casts a heavenly glow in any space. Design Christian Lava.













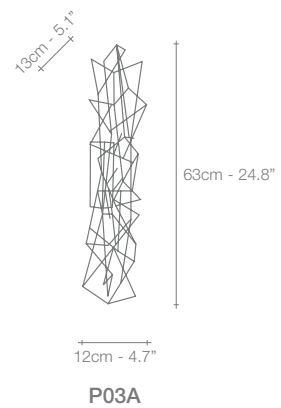
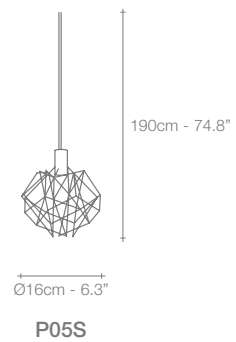
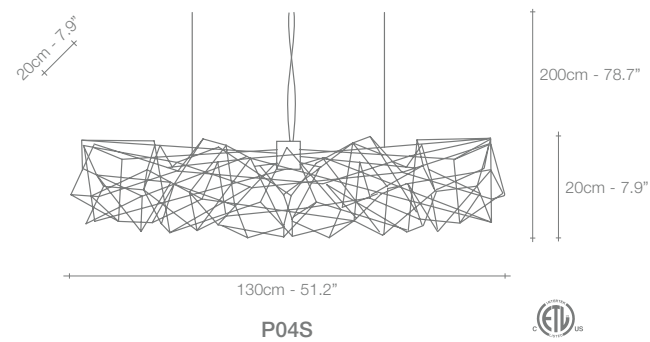
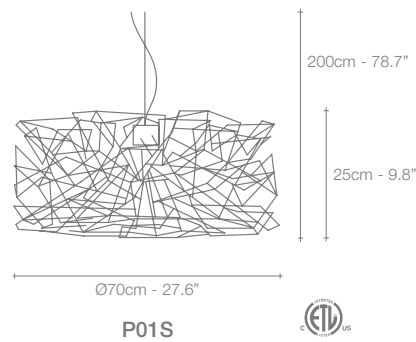

	P01S	P03A	P04S	P05S
230V	8X10W + HALOGEN 12V G4	6X10W	8X20W	20W
120V	8X10W + XENON BI-PIN 12V T3 G4	6X10W	8X20W	20W

ETOILE CAN BE  
MANUFACTURED TO WORK  
WITH BI-PIN LED LIGHT  
SOURCE ON REQUEST





# Anish, Playing *Spoons.*

A playful study of reflection, the idea for Anish was born when designer Dodo Arslan, while playing with his daughter, became fascinated by the almost infinite reflections spoons unleashed due to their concave and convex surfaces. Taking this idea to a larger scale, Dodo took inspiration from Italian flatware manufacturer Sambonet and created a pendant composed of a range of spoons from the smallest teaspoon to serving spoons which magnifies the reflective quality of this shape. The result is an installation that creates a "galaxy" effect of seemingly endless light. Design Dodo Arslan.













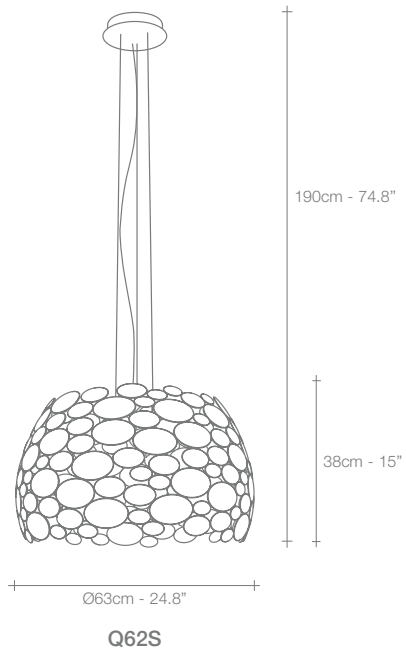

Q62S

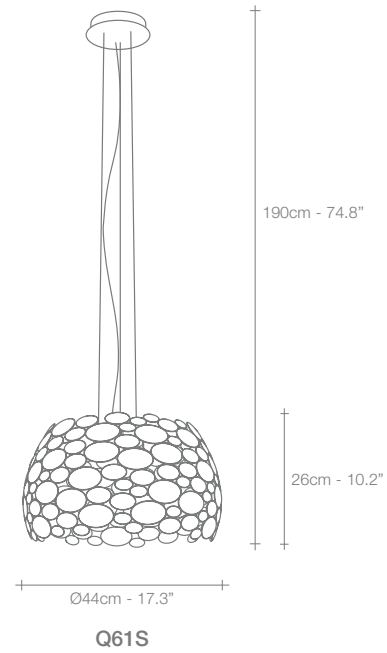

Q61S



NICKEL

230V / 120V

	Q61S	Q62S
LED BOARD		
3000 K		
CRI 90	6X4.5W	6X4.5W

2700K - CRI 90  
LED BOARD  
AVAILABLE ON  
REQUEST

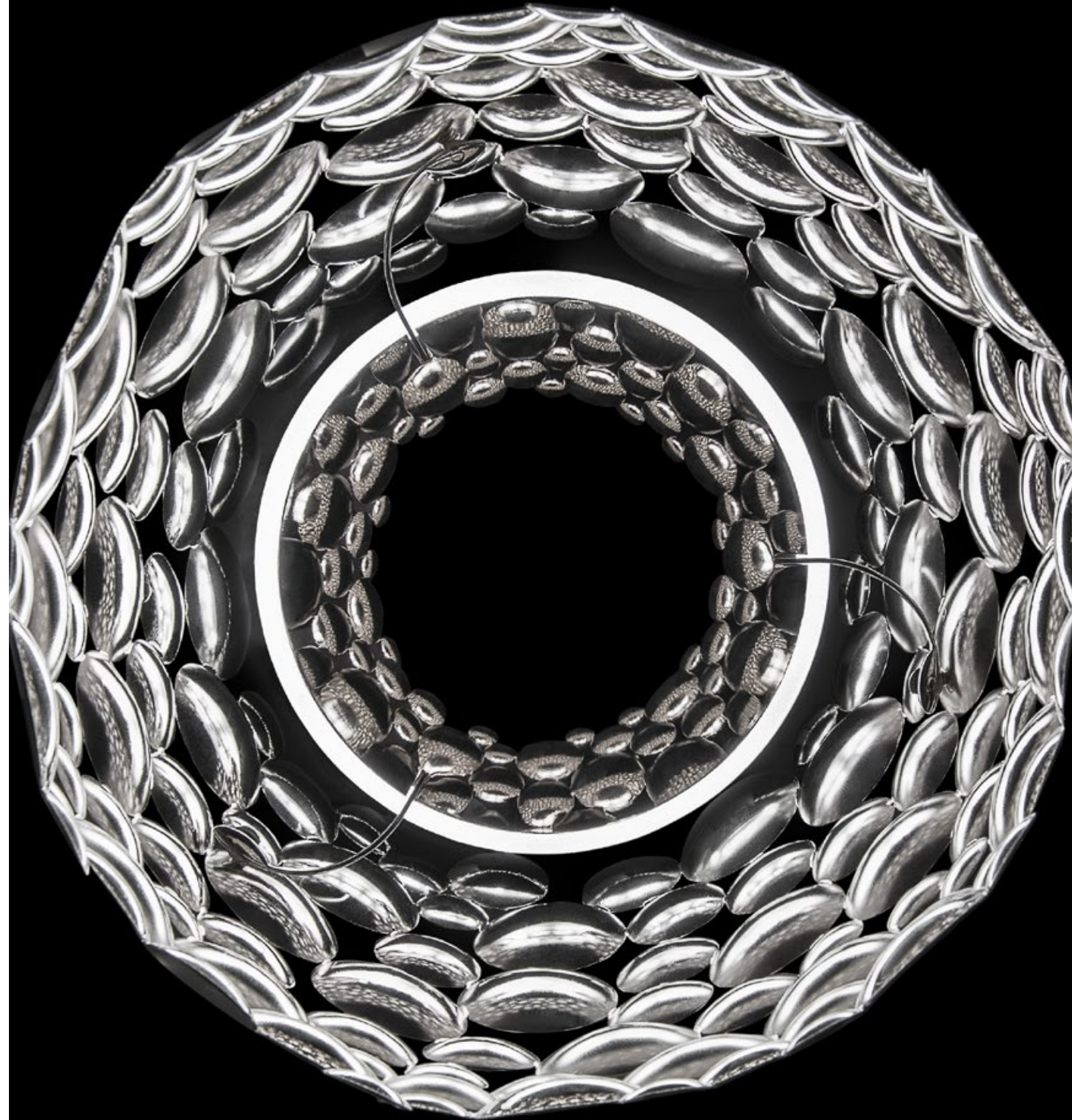



# Doodle, Freehand *Design.*

We no longer march in a straight line. Our lives are dynamic, intertwining collections of relationships, experiences and journeys. Reflecting the fluidity of our generation, designer Simone Micheli has created a new, contemporary light for Terzani, Doodle. Like us, each Doodle is unique, each pendant is handcrafted by artisans to resemble a randomised path. And, to give us control over the journey we want to take, each LED bulb can be placed anywhere on the light, not only reflecting the choices we make in life, but giving Doodle a special flexibility. Design Simone Micheli.













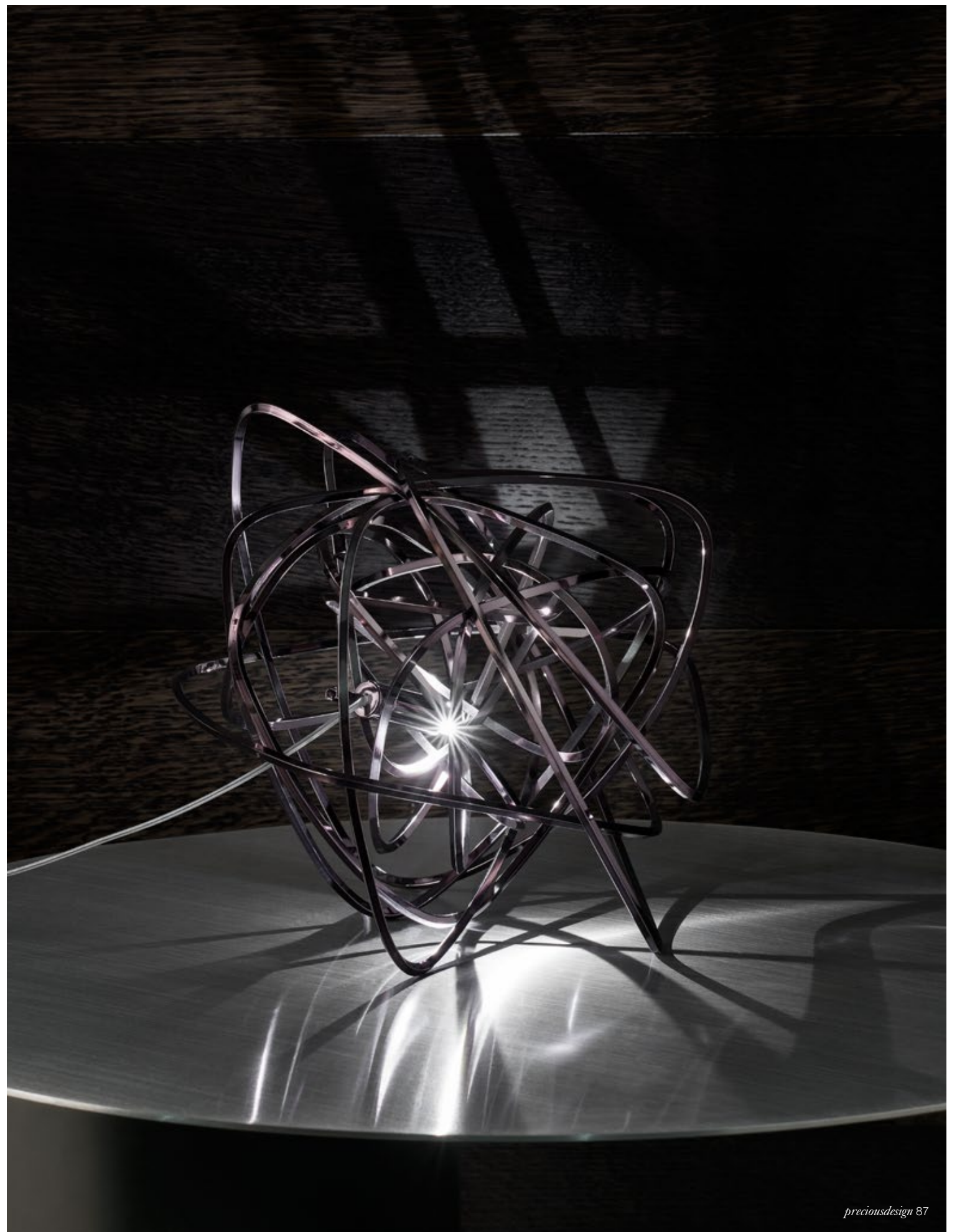



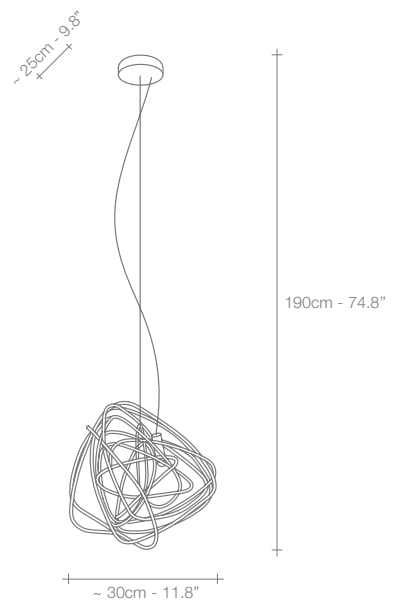

J80S



NICKEL



BLACK  
AMETHYST



GOLD

230V / 120V



J80S

LED PHILIPS G4  
CAPSULE LINE 1.2W G4  
COD. LED1WG427 (=10W)





# Core, Eruption *of Light.*

Core is reminiscent of the natural energy at the heart of our world. Like bright lava seeping through the earth's crust, vibrant spheres of faceted crystal break through the iron surface of this pendant. Forcing light to pass through this metal structure results in a powerful, vibrant exchange of forces light and shadow erupt across the room, as the LED light pours through, as the light itself emits an organic radiance. Design Christian Lava.









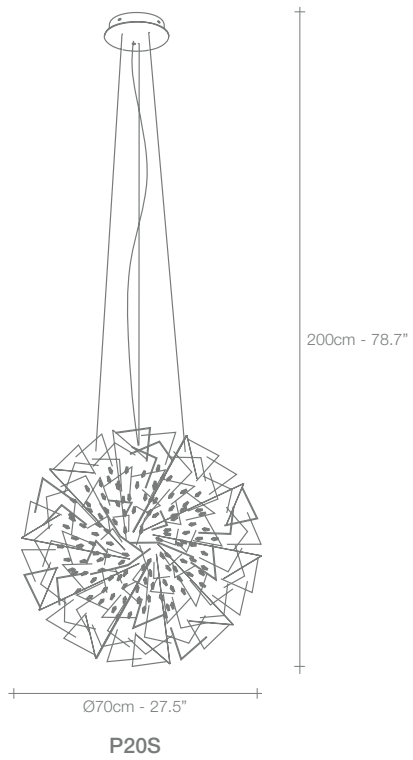

Ø70cm - 27.5"

P20S

200cm - 78.7"



NICKEL  
CLEAR



BLACK NICKEL  
CLEAR

230V / 120V



P20S

COB LED  
3000 K  
CRI 90

22W

2700K - CRI 90  
COB LED  
AVAILABLE ON  
REQUEST





# Argent, a Silver *Cloud.*

With this suspension light, designer Dodo Arslan creates a shimmering, silver cloud. Argent consists of metal discs that have been meticulously joined by hand by Terzani craftsmen into clusters. Once lit, the multiple, angled surfaces of the discs emanate a soft, shimmering, white glow. Design Dodo Arslan.

















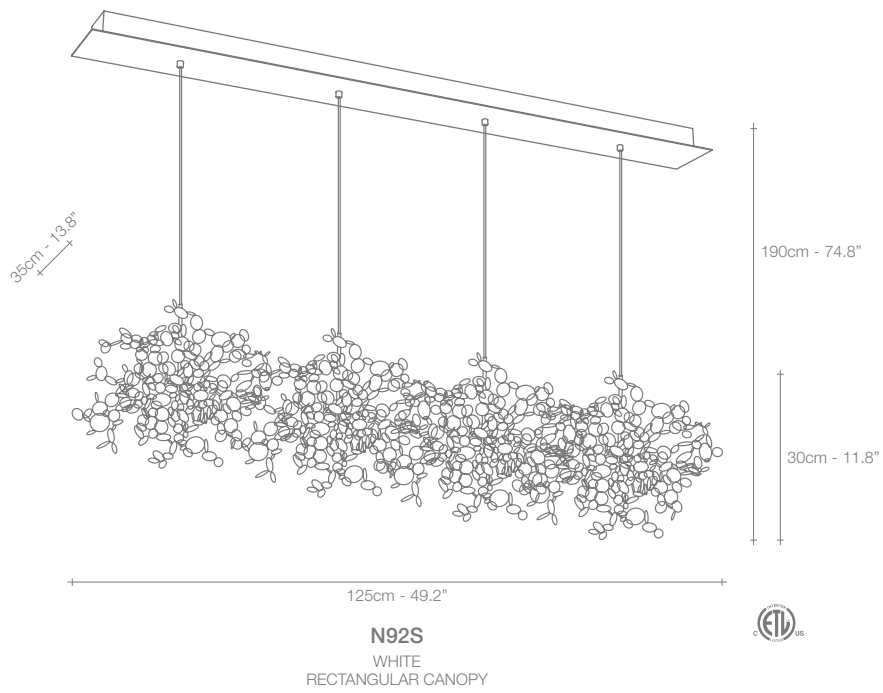
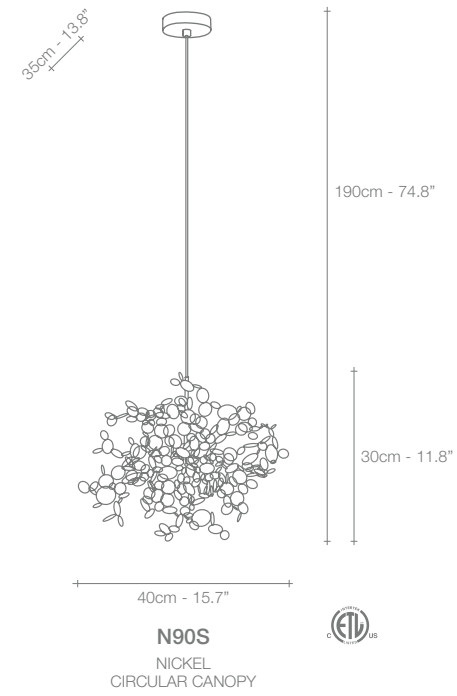
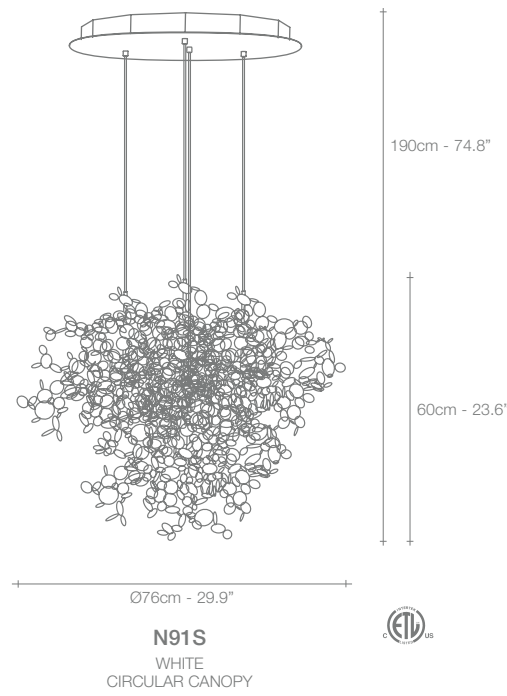

STAINLESS STEEL

	N90S	N91S	N92S
230V	HALOGEN 12V G4	3X20W	12X20W
120V	XENON BI-PIN 12V T3 G4	3X20W	12X20W

ARGENT CAN BE  
MANUFACTURED TO WORK  
WITH BI-PIN LED LIGHT  
SOURCE ON REQUEST





# I Lucci Argentati, School of *Light.*

I Lucci Argentati draws from nature to create a whimsical, yet modern light. Recalling a school of fish darting through freshwater, it creates a mesmerizing luminescence. Sets of sleek lights combine to form a stunning pendant with thin incisions along the bottom creating an understated, tranquil beauty. Thanks to its modular system, I Lucci Argentati is customizable and can be combined in many different configurations: from small to extra large; as a pendant or sconce; and finished either in brushed nickel or white. Design Dodo Arslan.





















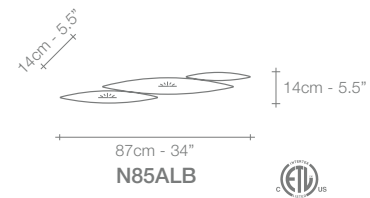
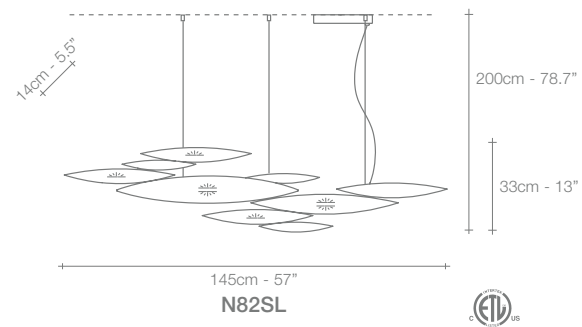
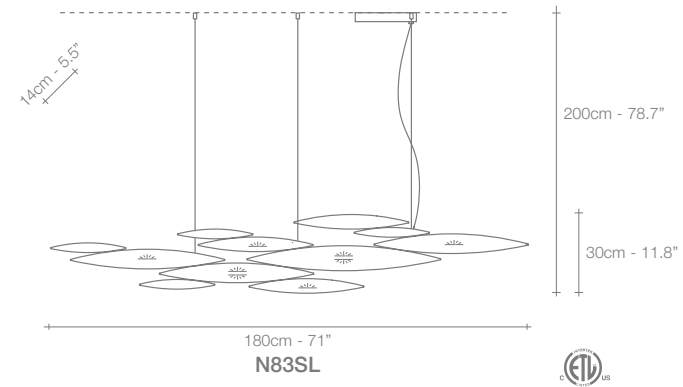
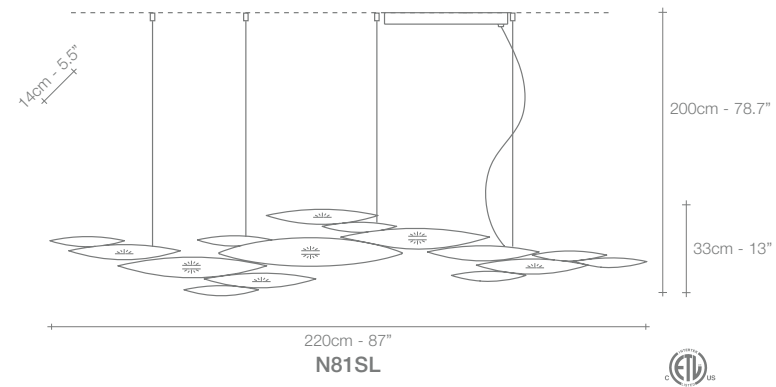
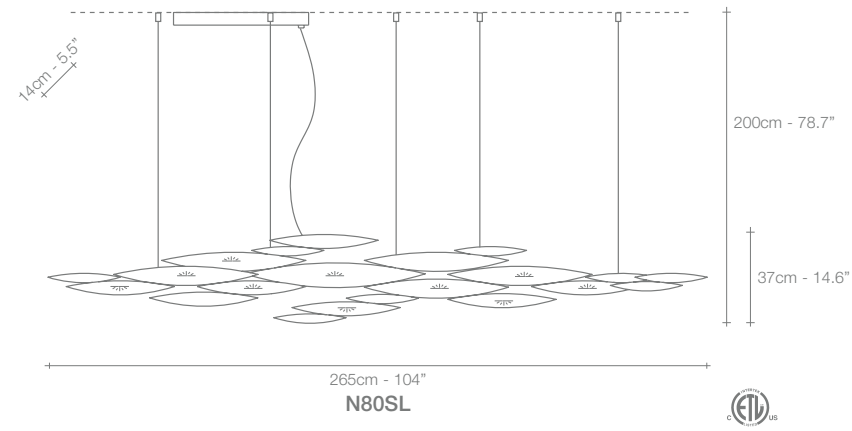

BRUSHED  
NICKEL

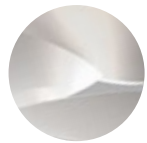

WHITE

230V / 120V

	N80SL	N81SL	N82SL	N83SL	N85SLB
LED BOARD					
3000 K					
CRI 90	10X4.5W	10X4.5W	7X4.5W	8X4.5W	2X4.5W

2700K - CRI 90  
LED BOARD  
AVAILABLE ON  
REQUEST





# Mizu, Flowing *Light.*

Inspired by the tranquil and mesmerizing light refractions created by water, Mizu is customizable pendant light from Terzani. Like water droplets, no two Mizu are alike, each crystal shape is unique and made meticulously by hand. Using only the clearest crystal (24% lead), Mizu perfectly emulates water's refraction of light, causing amazing patterns around the room, reminiscent of flowing water. Also available in gold leaf and silver dust. Design Nicolas Terzani.









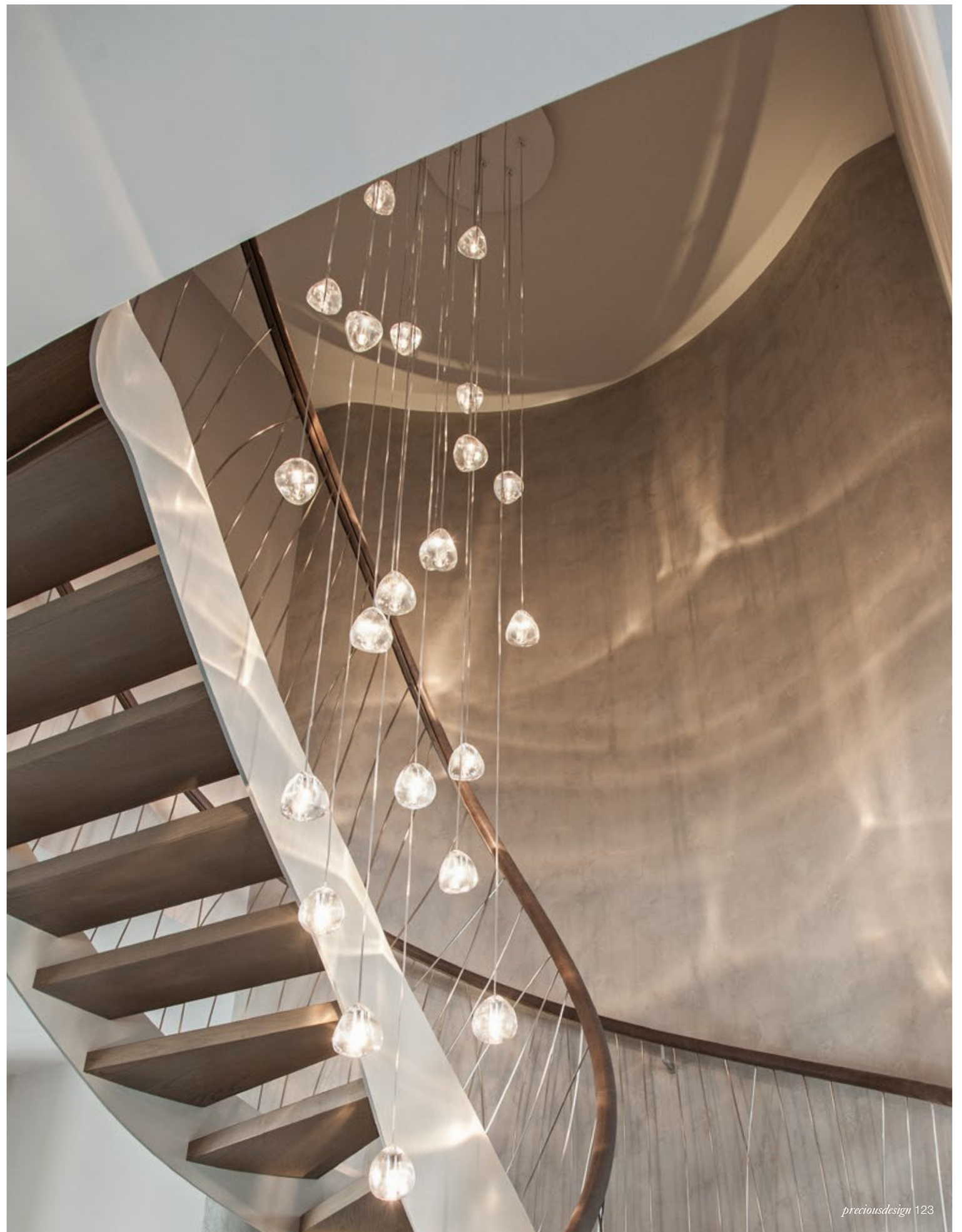











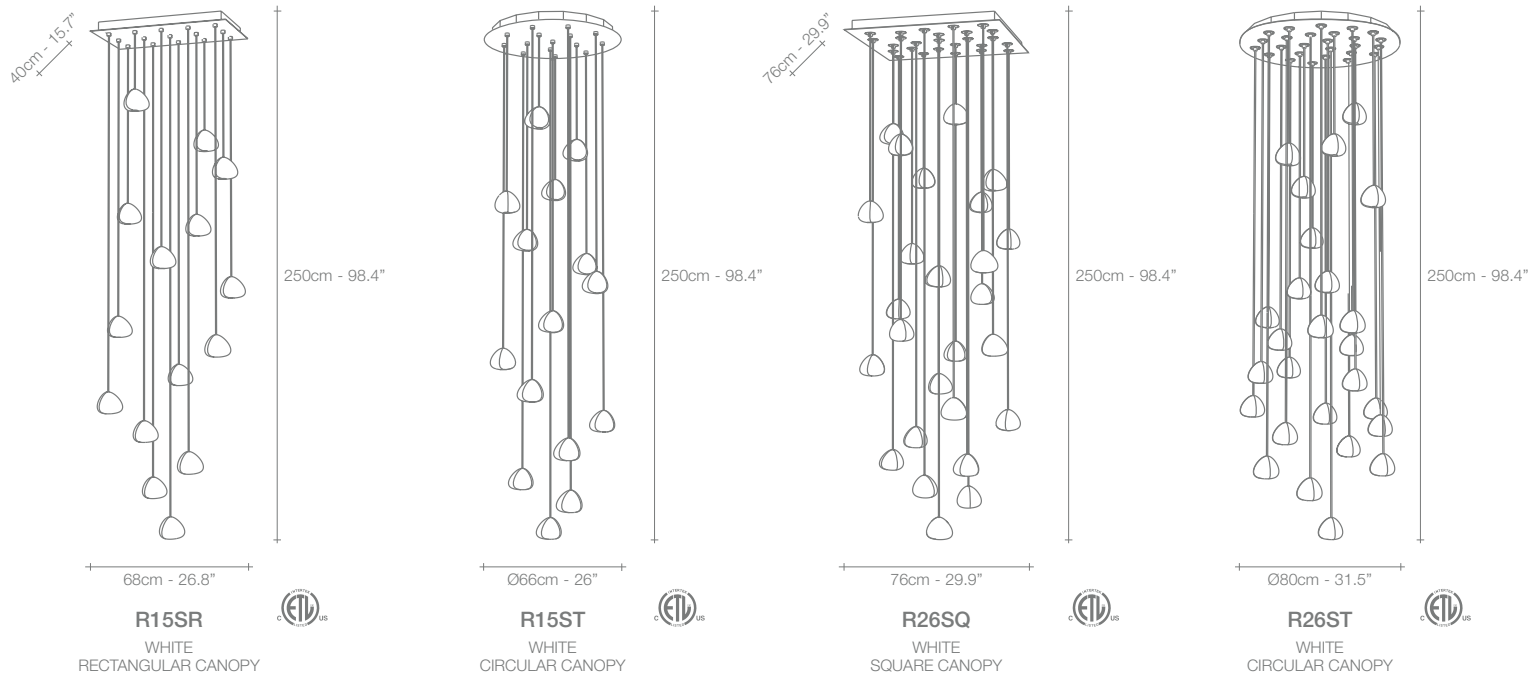
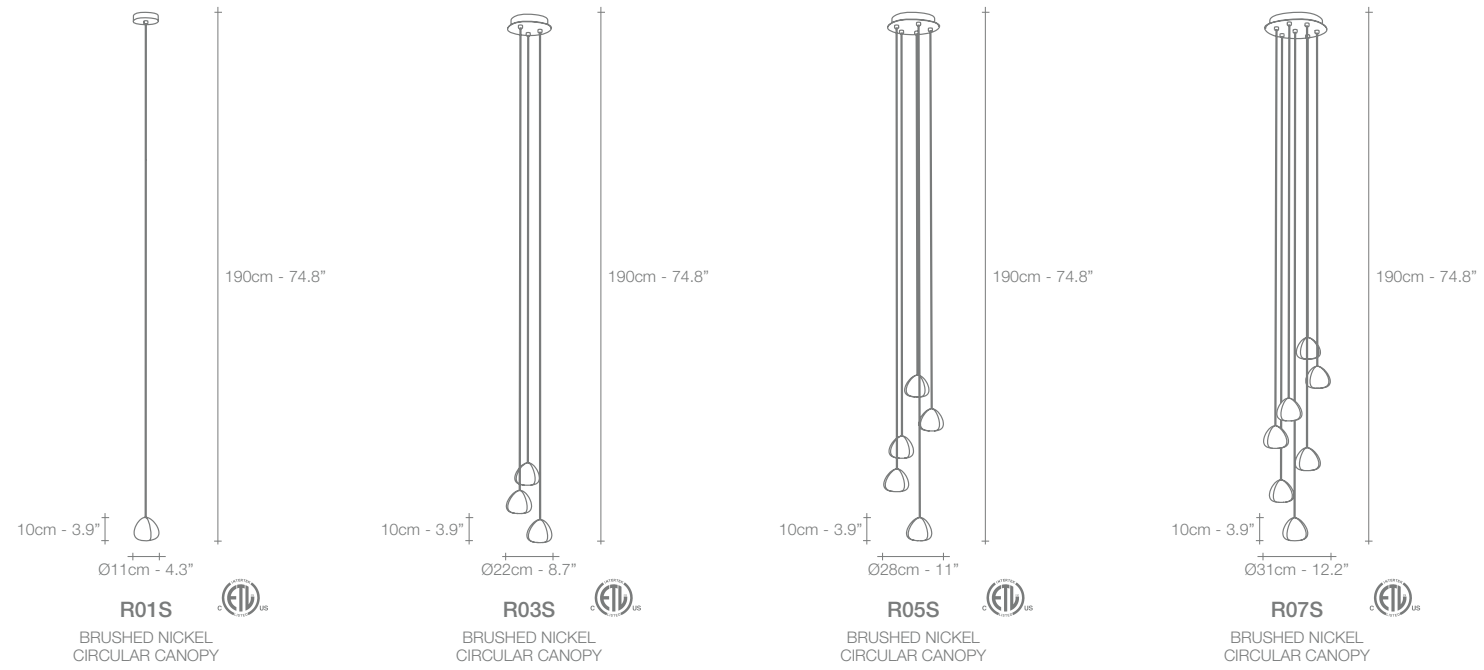

CRYSTAL



GOLD CRYSTAL



SILVER DUST CRYSTAL

	R01S	R03S	R05S	R07S	R15SR	R15ST	R26SQ	R26ST
230V HALOGEN 12V G4	10W	3X10W	5X10W	7X10W	15X10W	15X10W	26X10W	26X10W
120V XENON BI-PIN 12V T3 G4	10W	3X10W	5X10W	7X10W	15X10W	15X10W	26X10W	26X10W

MIZU CAN BE  
MANUFACTURED TO WORK  
WITH BI-PIN LED LIGHT  
SOURCE ON REQUEST





# Calle, Perennial *Elegance.*

At Terzani, we spend countless days searching the globe for talented new designers, but sometimes they find us. Such is the case with the young designers Luca Martorano and Mattia Albicini who approached us with the design for Calle, a fantastic new light we instantly fell in love with. It showcases our skill at crafting crystal to take the material to an exciting, modern place. Luca and Mattia worked with our craftsmen to create a slender inverted flute of 24% lead crystal that, like the calla lily it mimics, can be grouped into stunning bouquets of light. Design Luca Martorano and Mattia Albicini.

















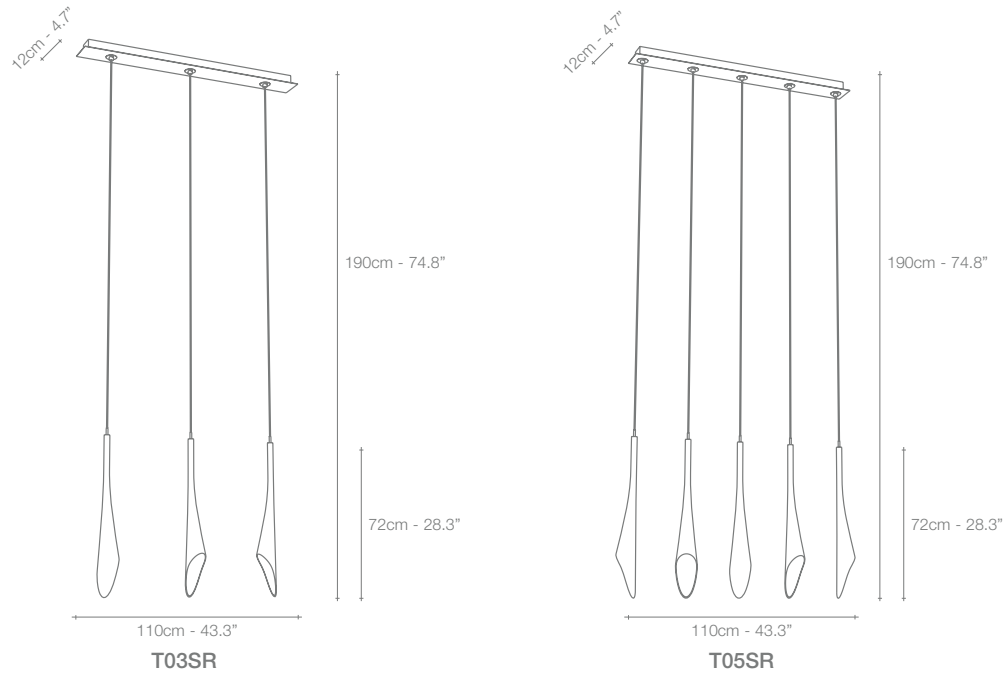
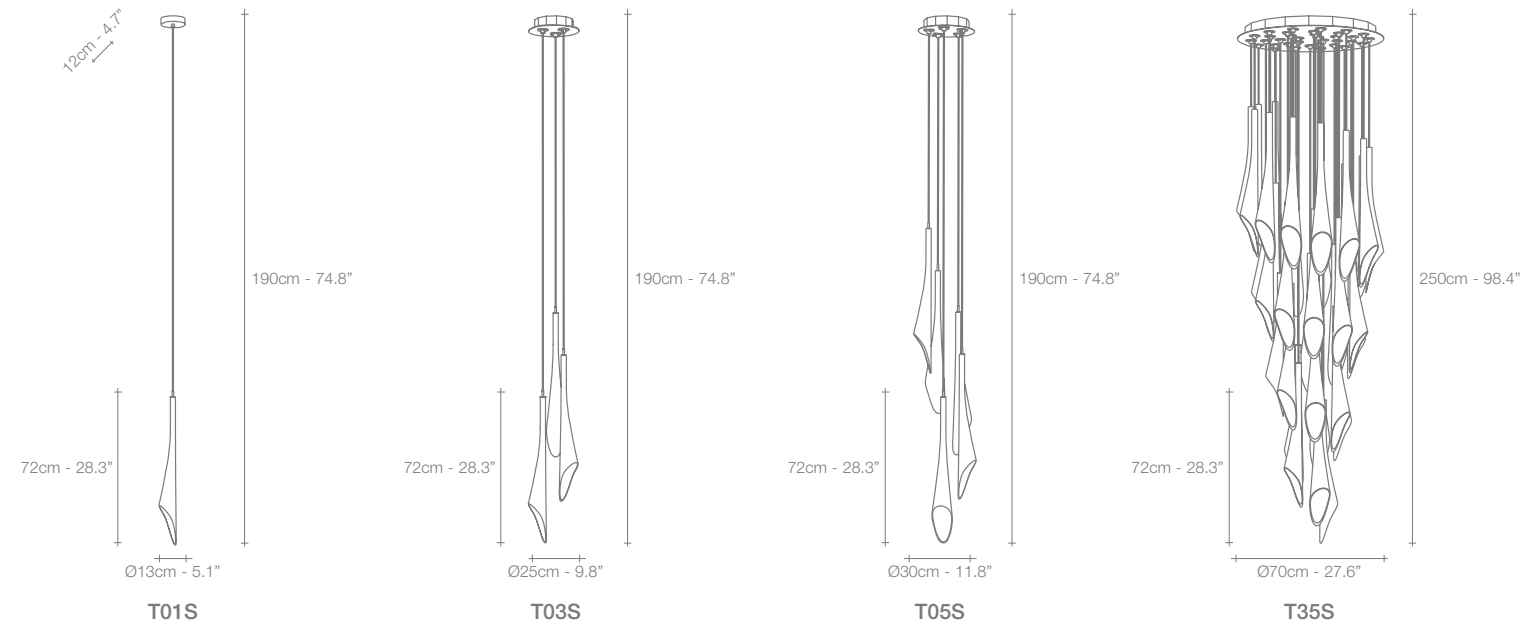

WHITE  
CRYSTAL

	T01S	T03S	T05S	T35S	T03SR	T05SR
230V	HALOGEN 12V G4	20W	3X20W	5X20W	35X10W	3X20W
120V	XENON BI-PIN 12V T3 G4	20W	3X20W	5X20W	35X10W	3X20W

CALLE CAN BE  
MANUFACTURED TO WORK  
WITH BI-PIN LED LIGHT  
SOURCE ON REQUEST





# Shar Pei , Lighthearted *Luxury.*

Shar Pei, employs sheaths of "wrinkled" crystal that take their cues from shar pei puppies. The "cute factor" is replaced by a stunning and elegant display created by the projection of light through the undulating 24% lead crystal. These lights can also be grouped together to create a "pack" of lights. Design Luca Martorano + Mattia Albicini.





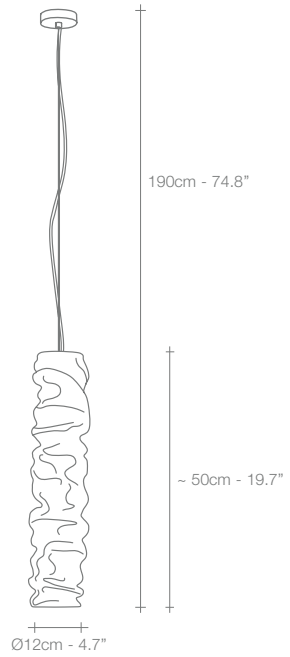

**Q02S**



CLEAR



**Q40S**

230V  
HALOGEN  
12V GY 6.35 35W  
(=40W)



120V  
XENON BI-PIN  
12V T3 GY 6.35 35W





# Angel Falls, Cast down *Earth.*

For his first work for Terzani, Nigel Coates, well known for his unorthodox approach to design, has created an engaging, unique light. Customizable groups of crystal (24% lead) "angels" are illuminated by halogen lamps. What caused these angels to fall from the heavens? It's up to the viewers to decide. Either way, angel falls is sure to garner attention, and generate conversation, in any setting. Design Nigel Coates.









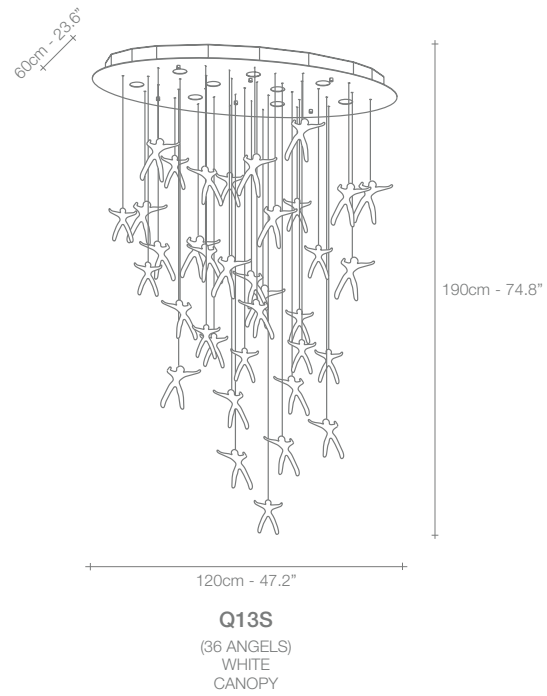
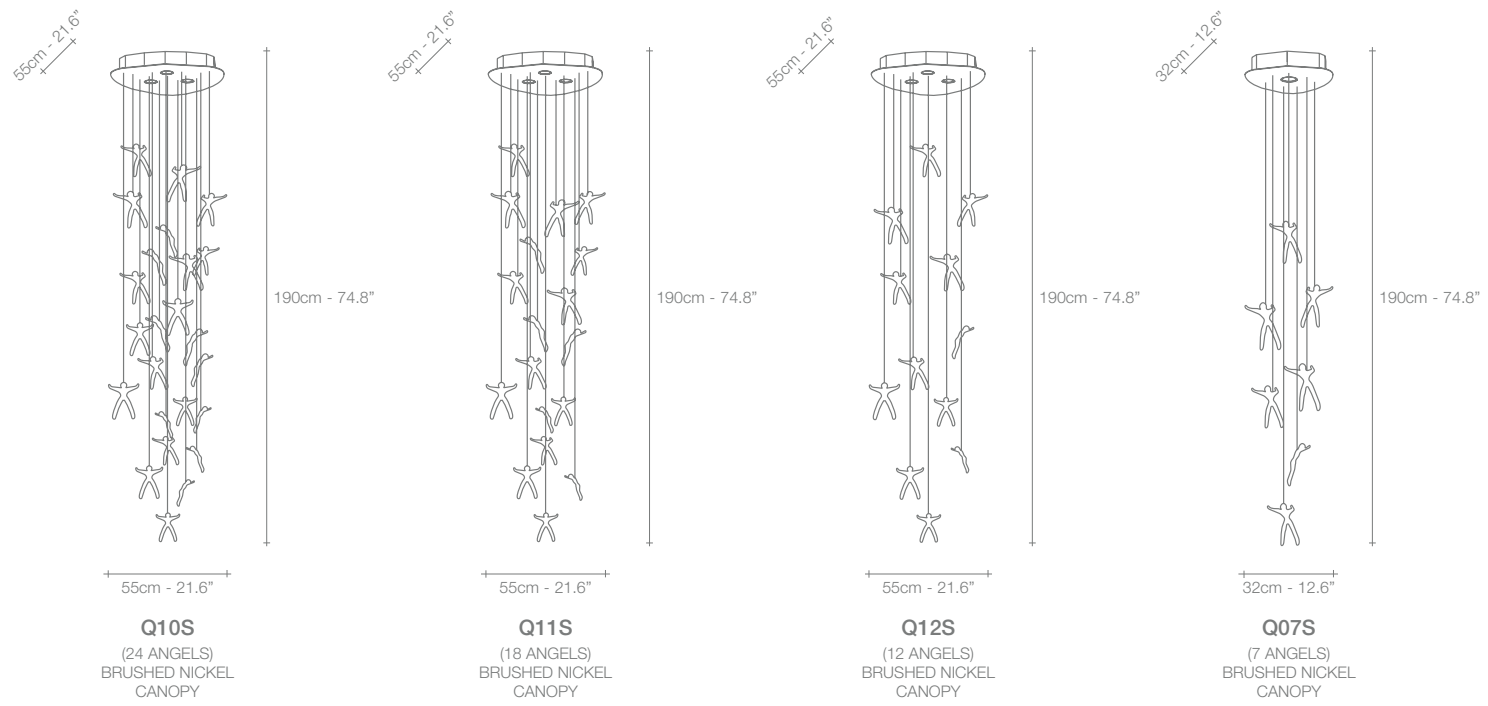

CRYSTAL

	Q07S	Q10S	Q11S	Q12S	Q13S
230V	HALOGEN GZ10 50W	3X50W	3X50W	3X50W	9X35W
120V	HALOGEN MR16 GU10 50W	3X50W	3X50W	3X50W	9X35W

LED LIGHT BULBS MAY BE USED

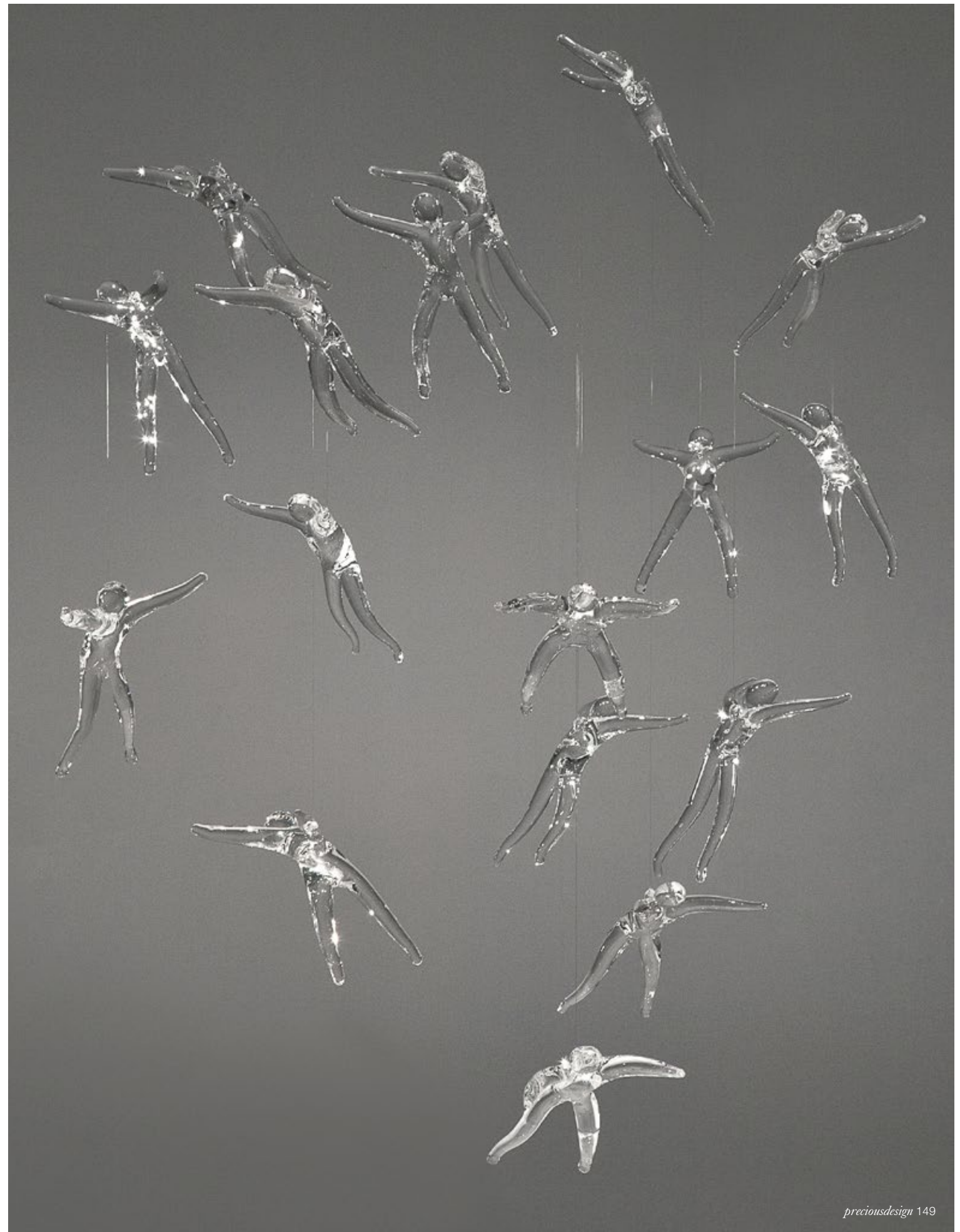



# Frame, Nature's *Imprint.*

Capturing a moment in time, Frame features a metal coral leaf, enclosed inside a borosilicate glass preserving a delicate imprint of nature. Hidden inside is a single bulb which glows from within. Creating a stirring light that projects a dynamic shadow due to the permeable coral. Frame is available in white, red, gold plated or silver plated. Design Terzani Lab.

















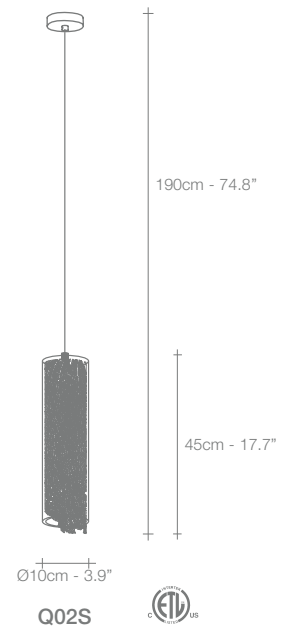

Q02S

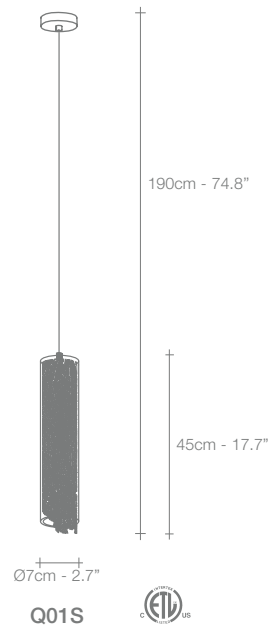

Q01S

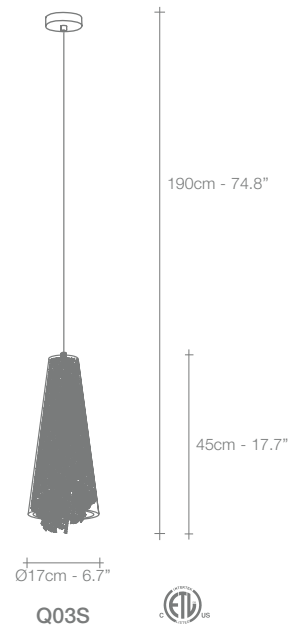

Q03S

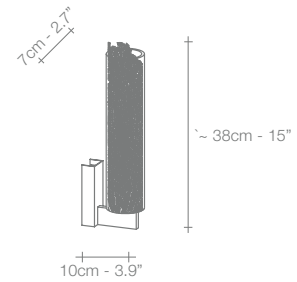

Q04A

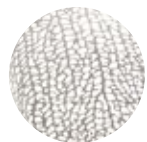

WHITE

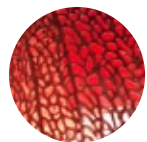

CORAL



SILVER



GOLD

230V		Q01S	Q02S	Q03S
	HALOGEN ES E14	28W (=40W)	28W (=40W)	42W (=60W)
120V				
	FLAME CA 10 E12	40W	40W	60W

	Q04S
	HALOGEN ES G9 (=40W)
	HALOGEN JCD G9 35W

LED LIGHT BULBS MAY BE USED

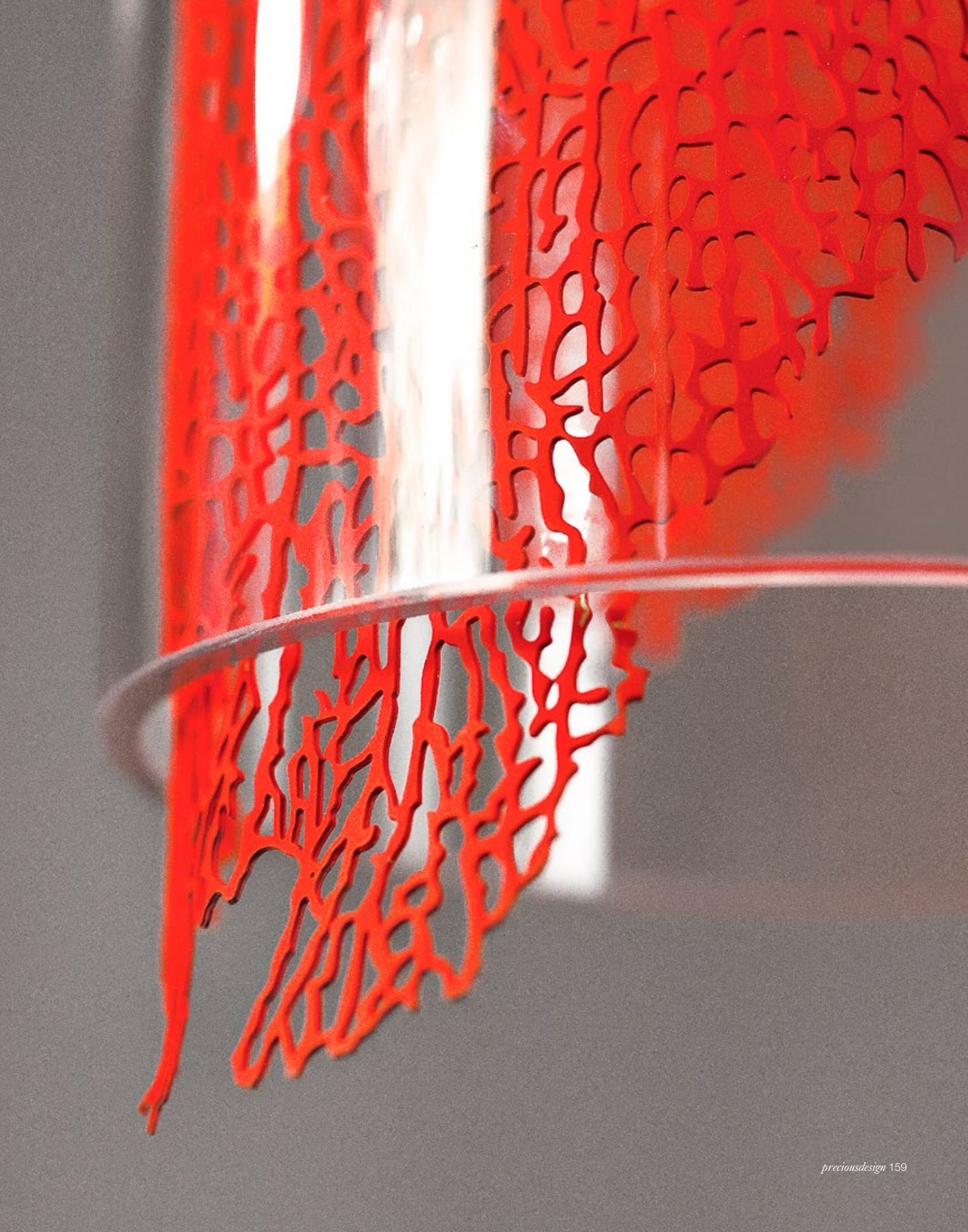



# Iceberg, Pure *Light.*

Inspired by the natural beauty of ice crystals, this new suspension light creates a spectacular, luminous piece through the use of over 3,600 plexyglass tubes. Similar to light refracting through water, the illumination created by Iceberg is both brilliant and natural, meticulously handcrafted, each light is a unique sculpture; sparkling, multifaceted and powerful. Design Dodo Arslan.





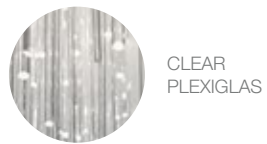
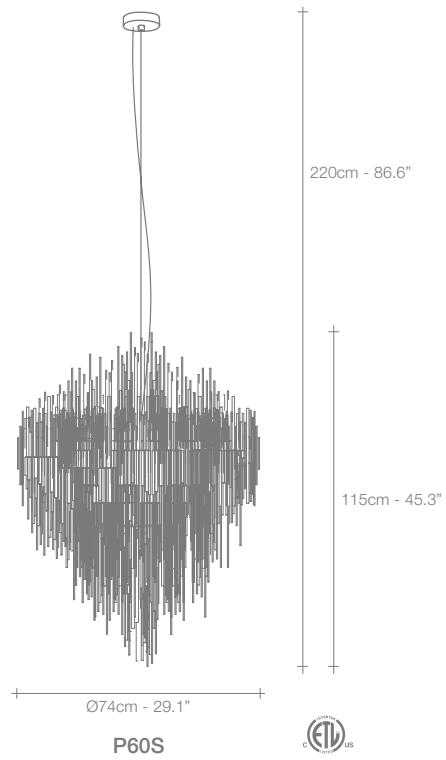

- P60S**
- |      |                   |   |                   |                     |
|------|-------------------|---|-------------------|---------------------|
| 230V | COMPACT FLUO. E14 | + | COMPACT FLUO. E27 | 6X14W E14 + 23W E27 |
| 120V | COMPACT FLUO. E12 | + | COMPACT FLUO. E26 | 6X12W E12 + 23W E26 |





# Orten'zia, Petals of *Light.*

Recalling the natural beauty of a flower, Orten'zia hand-soldered "petals" emanate a unique glow, immersing the entire room in a glimmering light. An organic radiance is created through light and shadow, planting a garden within the room. Available in either nickel or gold plated, the orten'zia's elegant form complements its dramatic light. Design Bruno Rainaldi.

























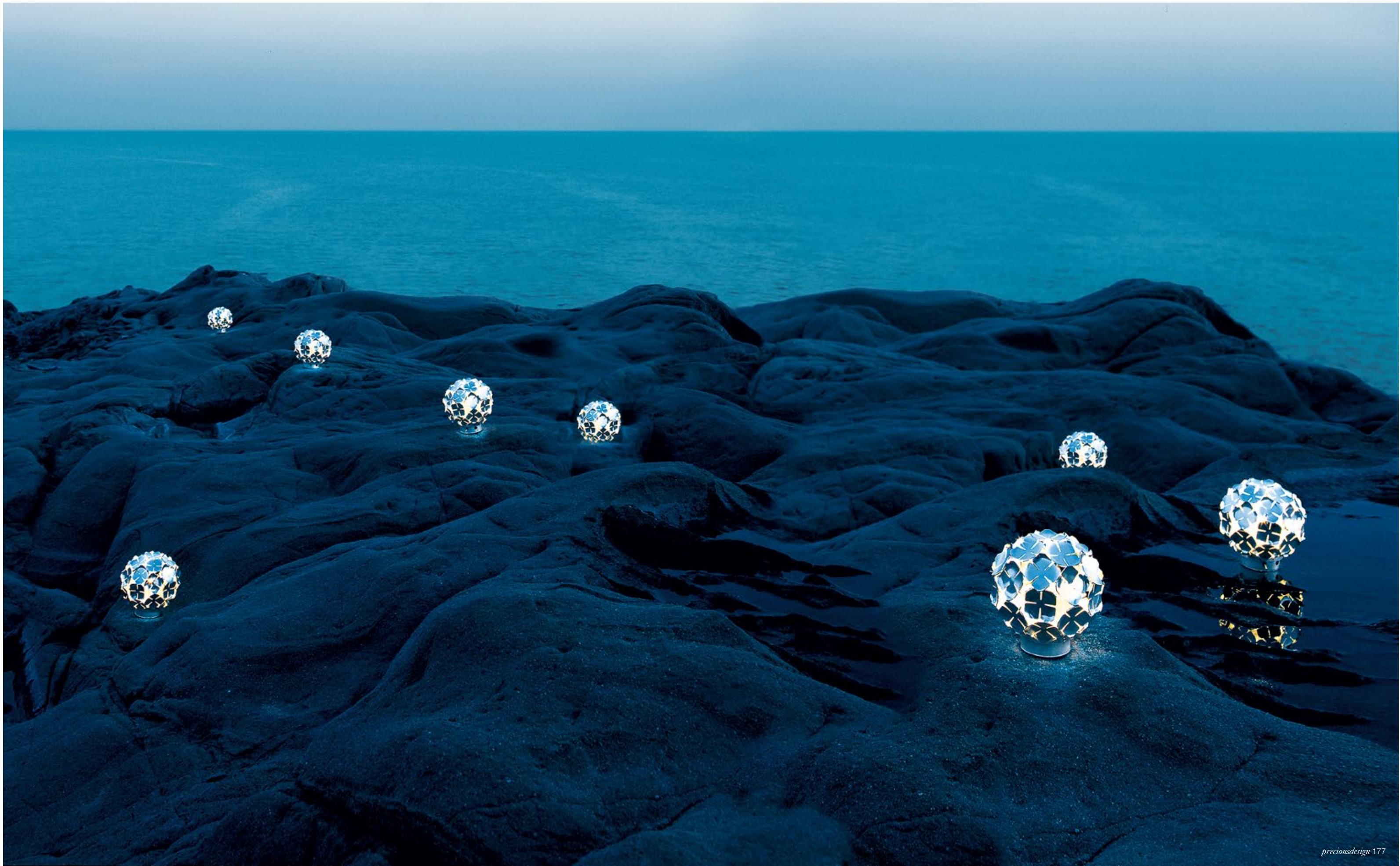







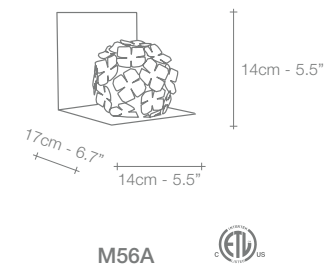
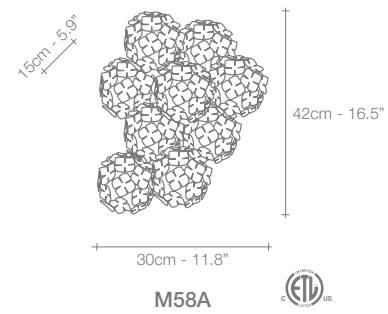
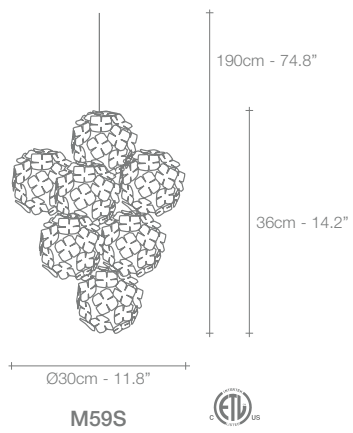
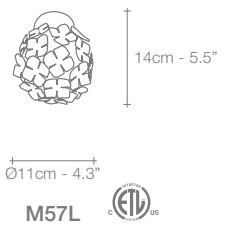
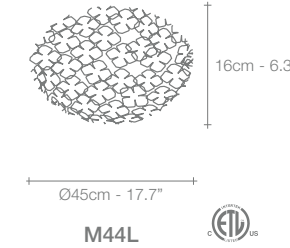
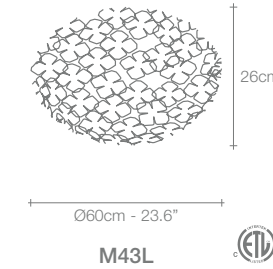
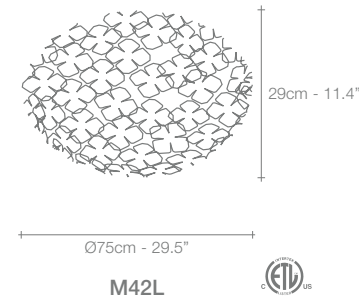
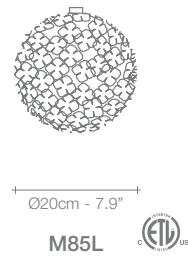
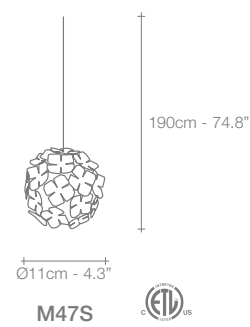
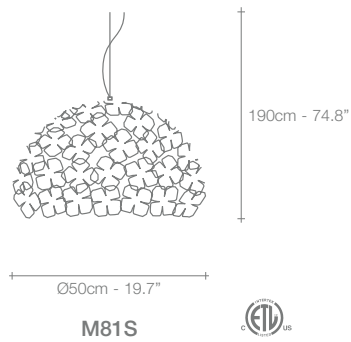
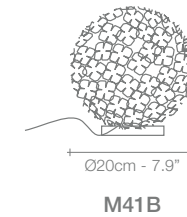
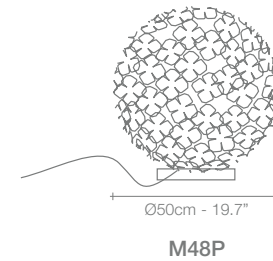
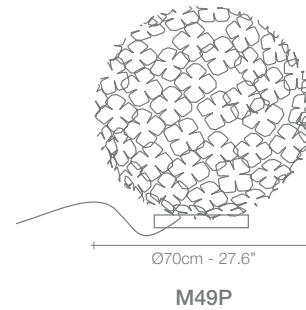
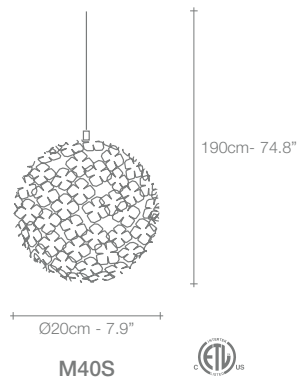
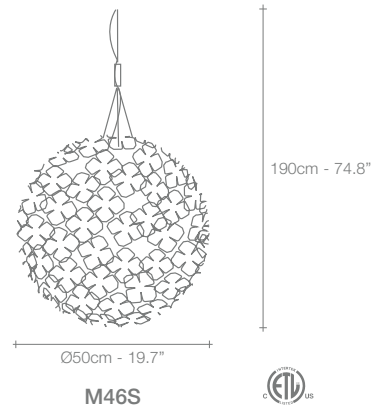
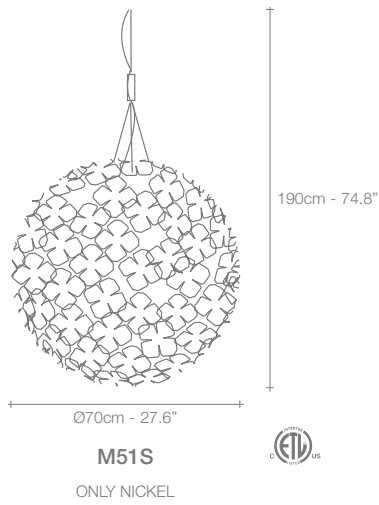

230V		<b>M40S</b>	<b>M41B</b>		<b>M42L</b>	<b>M43L</b>	<b>M46S</b>	<b>M48P</b>	<b>M49P</b>	<b>M51S</b>		<b>M44L</b>		<b>M50B</b>
	HALOGEN ES E14	42W (=60W)	42W (=60W)		HALOGEN ES E27	140W (=200W)	105W (=150W)	140W (=200W)	105W (=150W)	140W (=200W)		140W (=200W)		HALOGEN ES R7S
120V		<b>M40S</b>	<b>M41B</b>		<b>M42L</b>	<b>M43L</b>	<b>M46S</b>	<b>M48P</b>	<b>M49P</b>	<b>M51S</b>		<b>M44L</b>		<b>M50B</b>
	KX-2000 T3 E12	40W	40W		CLEAR STD. TYPE A E26	A23 200W	A23 200W	A23 200W	A21 150W	A23 200W		A23 200W		HALOGEN J-SHORT R7S

230V		<b>M47S</b>	<b>M56A</b>	<b>M57L</b>	<b>M58A</b>	<b>M59S</b>	<b>M85L</b>		<b>M81S</b>
	HALOGEN ES G9	48W (=60W)	48W (=60W)	33W (=40W)	5X33W (=5X40W)	60W (=75W)	33W (=40W)		COMPACT FLUO. E27
120V		<b>M47S</b>	<b>M56A</b>	<b>M57L</b>	<b>M58A</b>	<b>M59S</b>	<b>M85L</b>		<b>M81S</b>
	HALOGEN JCD G9	50W	50W	50W	5X35W	50W	35W		GLOBE G40 E26



# Bond, brands of *Racing Light.*

Bond's bands of light expose a deceptively luxurious interior. Under the glass exterior, lays a core of gold leaf that creates a deep, complex radiance. The overall glow is intensified by incisions that emit focused, dramatic lines of light. Extremely versatile, Bond is available in three sizes; as either a pendant or a table/floor light; and with a black or white exterior. Whether alone or grouped together, Bond's light creates a dynamic atmosphere. Design Bruno Rainaldi.

















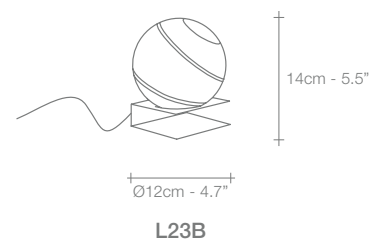
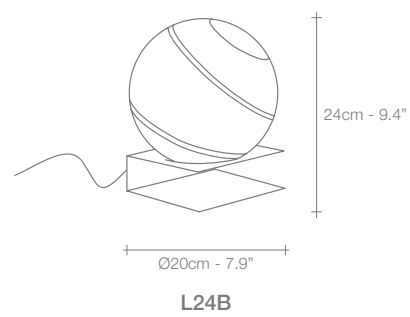
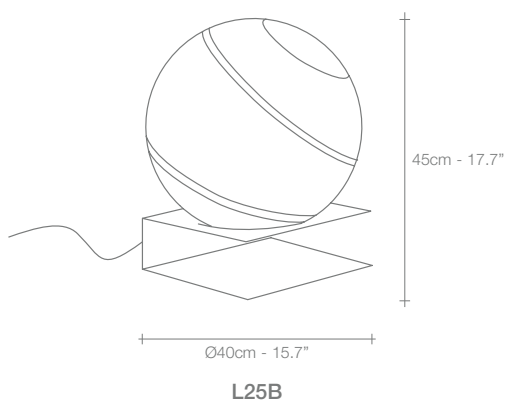
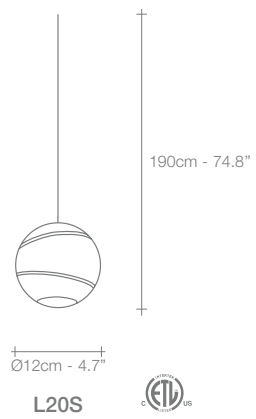
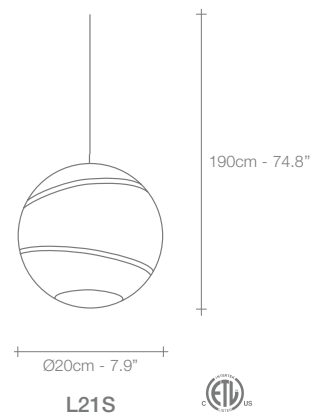
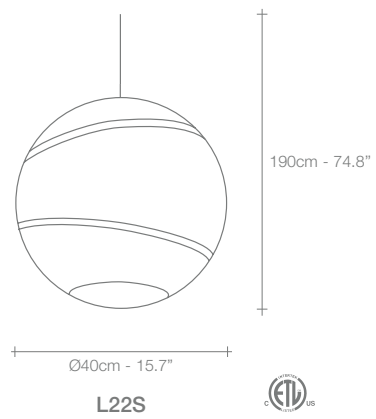

CLEAR GLASS  
WHITE WITH  
GOLD LEAF



CLEAR GLASS  
BLACK WITH  
GOLD LEAF

	L20S	L23B	L21B	L22S	L25B	L24B				
230V	HALOGEN ES G9	20W (=25W)	20W (=25W)	HALOGEN ES E14	42W (=60W)	HALOGEN ES E27	70W (=100W)	70W (=100W)	HALOGEN ES E14	42W (=60W)
120V	HALOGEN JCD G9	20W	20W	HALOGEN JCD G9	35W	HALOGEN ECO A19 E26	72W (=100)	72W (=100)	CLEAR GLOBE G16 1/2 E12	60W





G.r.a,  
gyrating Romantic  
*rings of Light.*

This clean, precise form is the result of hours of labor by our artisans, who meticulously weld each ring together. G.r.a. is a delicate, refined pendant whose intricate shape belies its romantic glow. Available as an oval or a sphere, and finished in nickel or gold, G.r.a. serves as an elegant, unobtrusive complement to any room. Design Bruno Rainaldi.













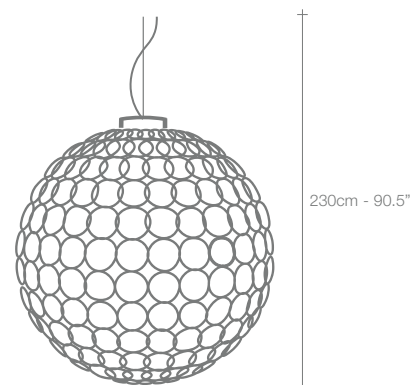

Ø90cm - 35.4"

N40S OR N40SL

230cm - 90.5"

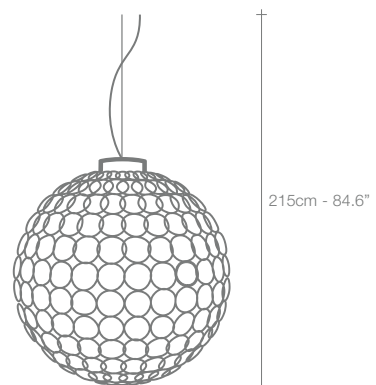

Ø70cm - 27.6"

N42S OR N42SL

215cm - 84.6"

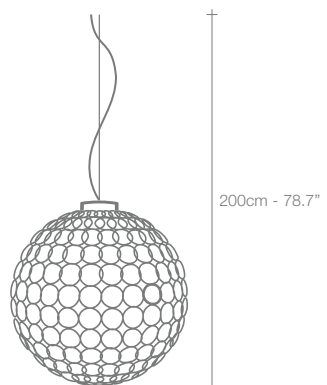

Ø54cm - 21.6"

N43S OR N43SL

200cm - 78.7"

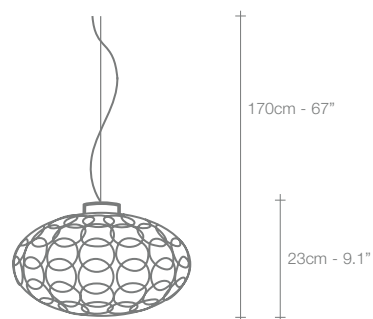

Ø50cm - 19.7"

N41S OR N41SL

170cm - 67"

23cm - 9.1"



NICKEL

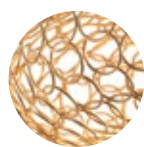

GOLD LEAF

230V / 120V



N40S N41S N42S N43S

OR



N40SL N41SL N42SL N43SL

HALOGEN  
R 111 GU10 100W 100W 100W 100W

COB LED  
3000 K  
CRI 90

22W 22W 22W 22W

2700K - CRI 90  
COB LED  
AVAILABLE ON  
REQUEST

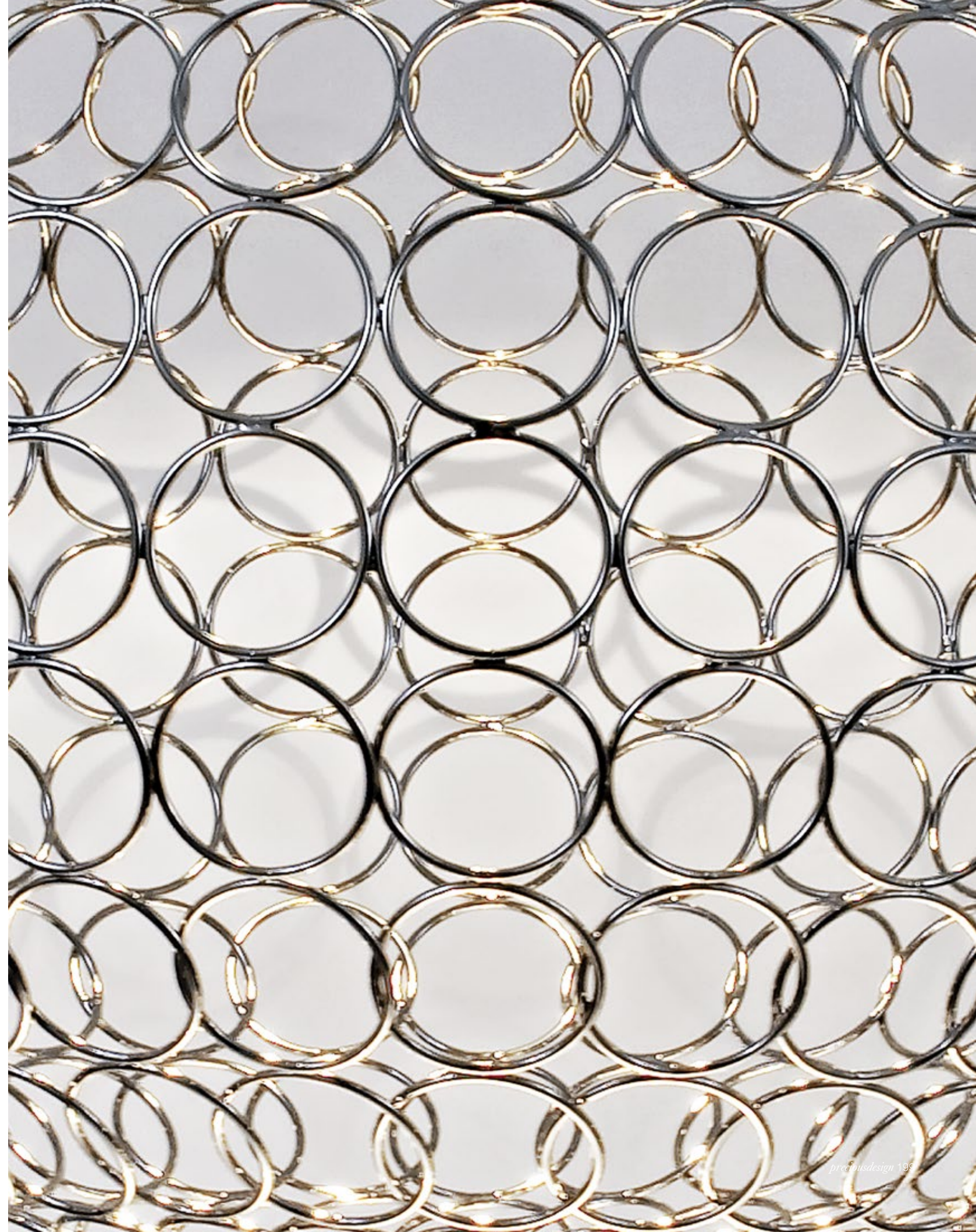



# Magdalena, Cutting edge *Beauty.*

Reaching inside traditional forms, Magdalena's laser-cut, horizontal openings allow for its light to expand its range to the entire room. Creating an alluring pattern of light and shadow, Magdalena highlights the shape of the room itself. This unique exchange creates a pendant that impacts every space, regardless of size. Design Bruno Rainaldi.





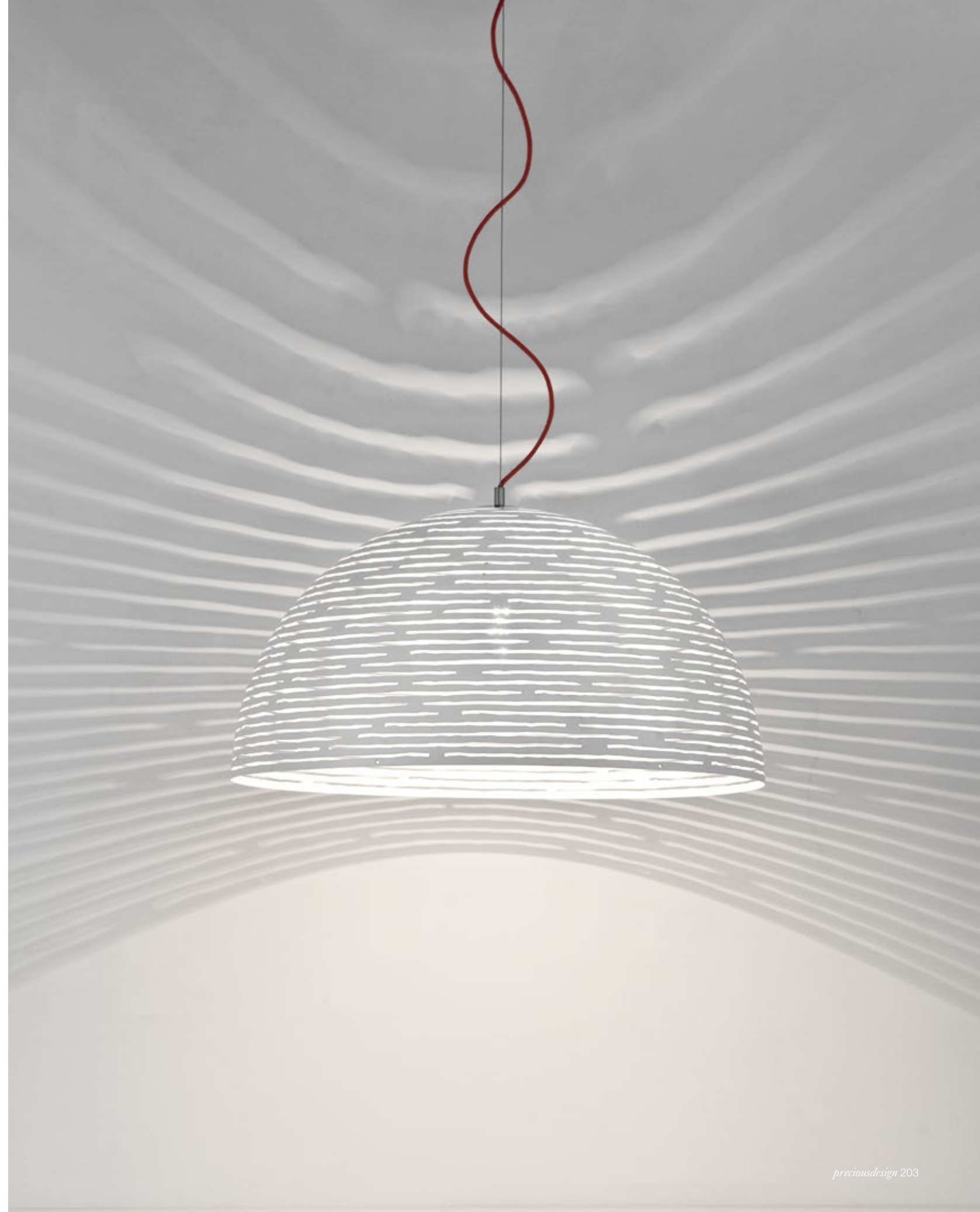



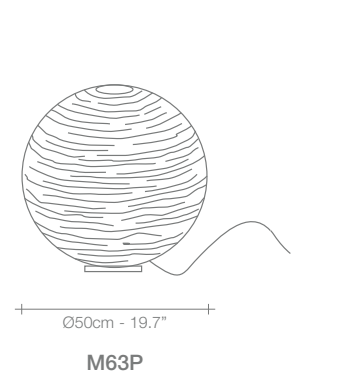
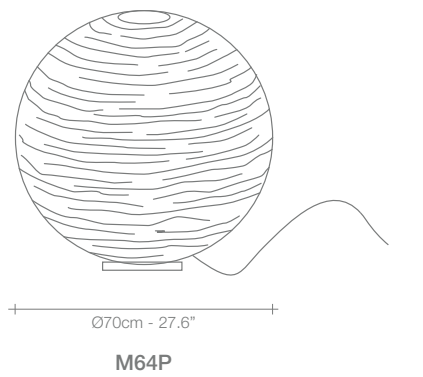
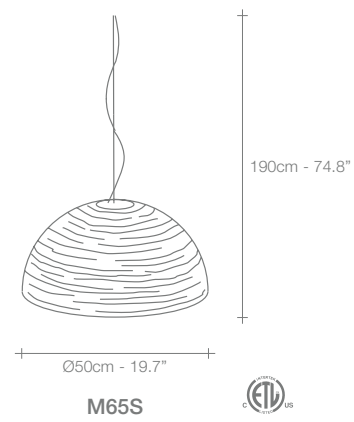
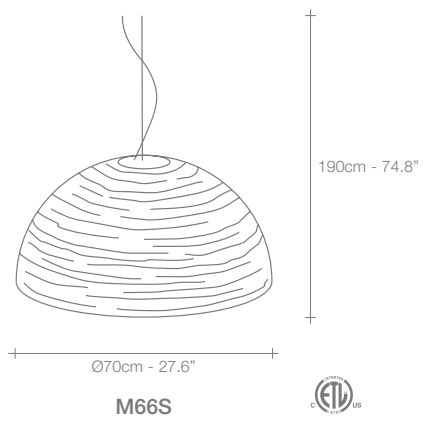
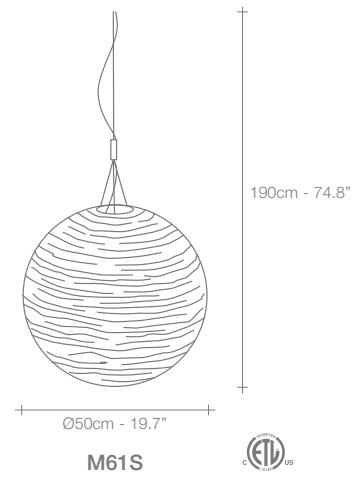
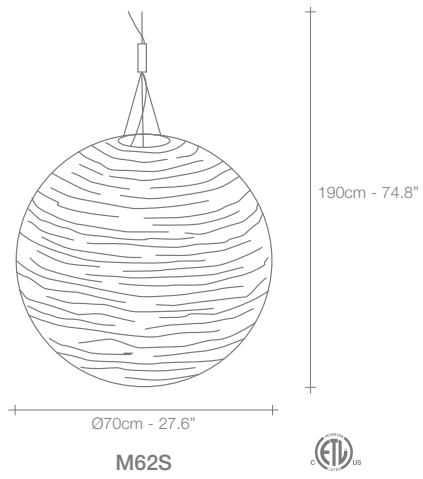

230V		<b>M61S</b>	<b>M62S</b>	<b>M63P</b>	<b>M64P</b>		<b>M65S</b>	<b>M66S</b>
	HALOGEN ES E27	140W (=200W)	140W (=200W)	105W (=150W)	140W (=200W)	COMPACT FLUO. E27	23W	23W
120V								
	CLEAR STD. A23 E26	200W	200W	200W	200W	GLOBE G40 E26	150W	150W





# Glamour, Modern *Seduction.*

Glamour's randomly interspersed rings imbue this design with a seductiveness rarely applied to geometric shapes. Whether finished in gold, nickel or white, the diffused light emanating behind Glamour's rings bathes the surrounding area in a soft, sensuous glow. Available as a wall sconce, table lamp or pendant, glamour can provide subtle accents or act as the focal point of a room. Design Dodo Arslan.









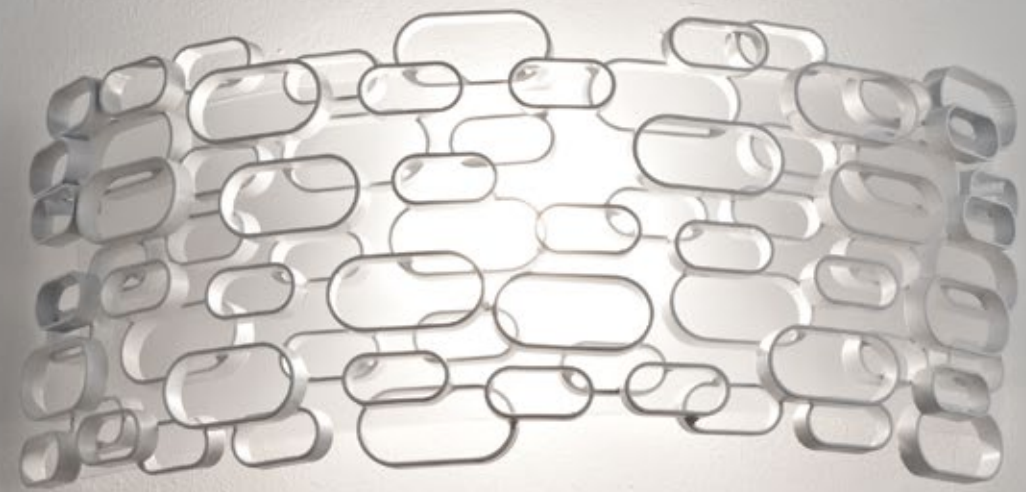







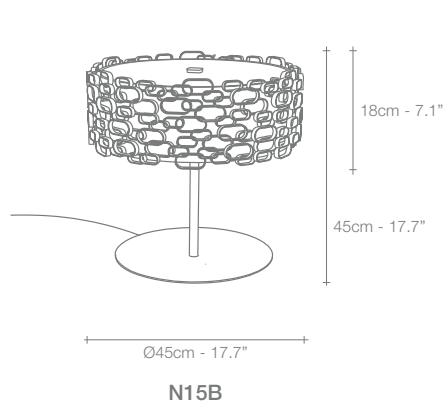

**N15B**

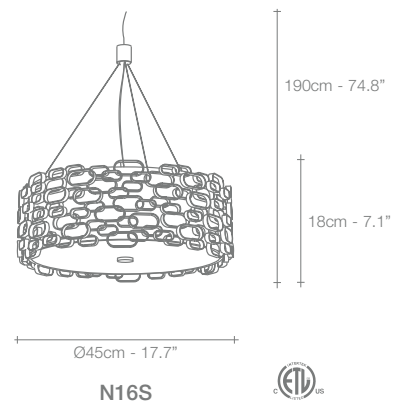

**N16S**

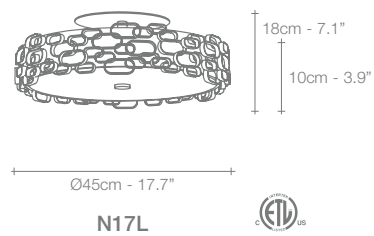

**N17L**



16cm - 6.3"

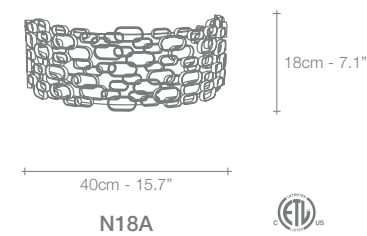

**N18A**



WHITE



NICKEL



GOLD

	N15B	N16S	N17L	N18A
230V	 HALOGEN ES E14 3X28W (=3X40W)	 HALOGEN ES R7S 3X28W (=3X40W)	 HALOGEN ES R7S 3X28W (=3X40W)	 HALOGEN ES R7S 48W (=60W)
120V	 CLEAR GLOBE G12 E12 3X40W	 CLEAR GLOBE G12 E12 3X40W	 CLEAR GLOBE G12 E12 3X40W	 HALOGEN J-SHORT R7S 75W





# Wabi, Understated *Elegance.*

Influenced by the rustic simplicity of the mulberry tree, Nicolas Terzani set out to create a piece that delivered the same quiet, harmonious elegance. Thus, wabi, available in white, gold-plated or silver-plated finish, which recalls the serenity and balance of its natural inspiration. The texture of wabi harnesses the anomalies of a cortex, resulting in a unique and classic light. Design Nicolas Terzani.





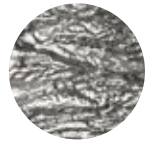
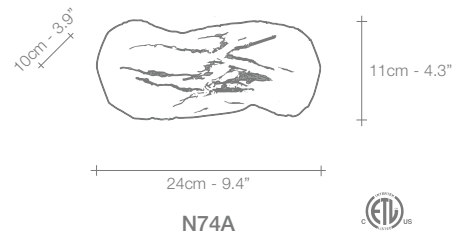

NICKEL



GOLD

N74A



230V

HALOGEN ES R7S 48W (=60W)



120V

HALOGEN J-SHORT R7S 75W





# Untitled, Beauty is in the eye *of the Beholder.*

A powerful work of art has a unique meaning for each viewer. With Untitled, laser-cut stainless steel frames create a depth and complexity that changes at every angle, providing a dynamic element to any space. This unique design elicits a range of responses and provides an intriguing element that stands the test of time. Design Bruno Rainaldi.





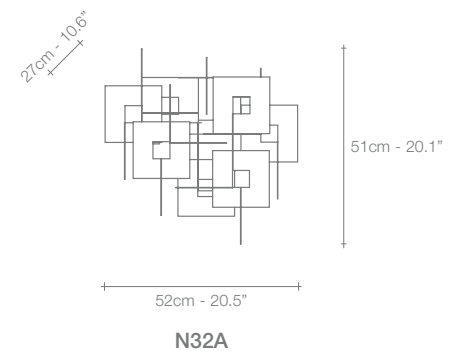
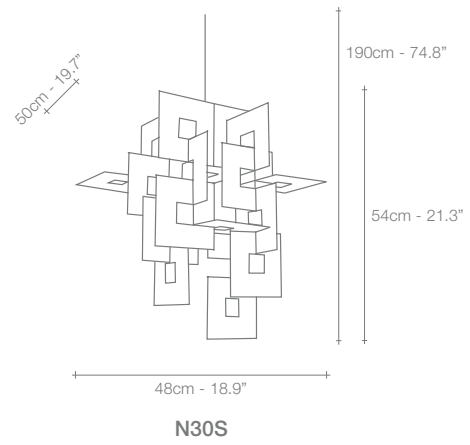

	N30S	N32S
230V	HALOGEN ES G9 5X33W (=5X40W)	4X33W (=4X40W)
120V	HALOGEN JCD G9 5X35W	4X35W

LED LIGHT BULBS MAY BE USED

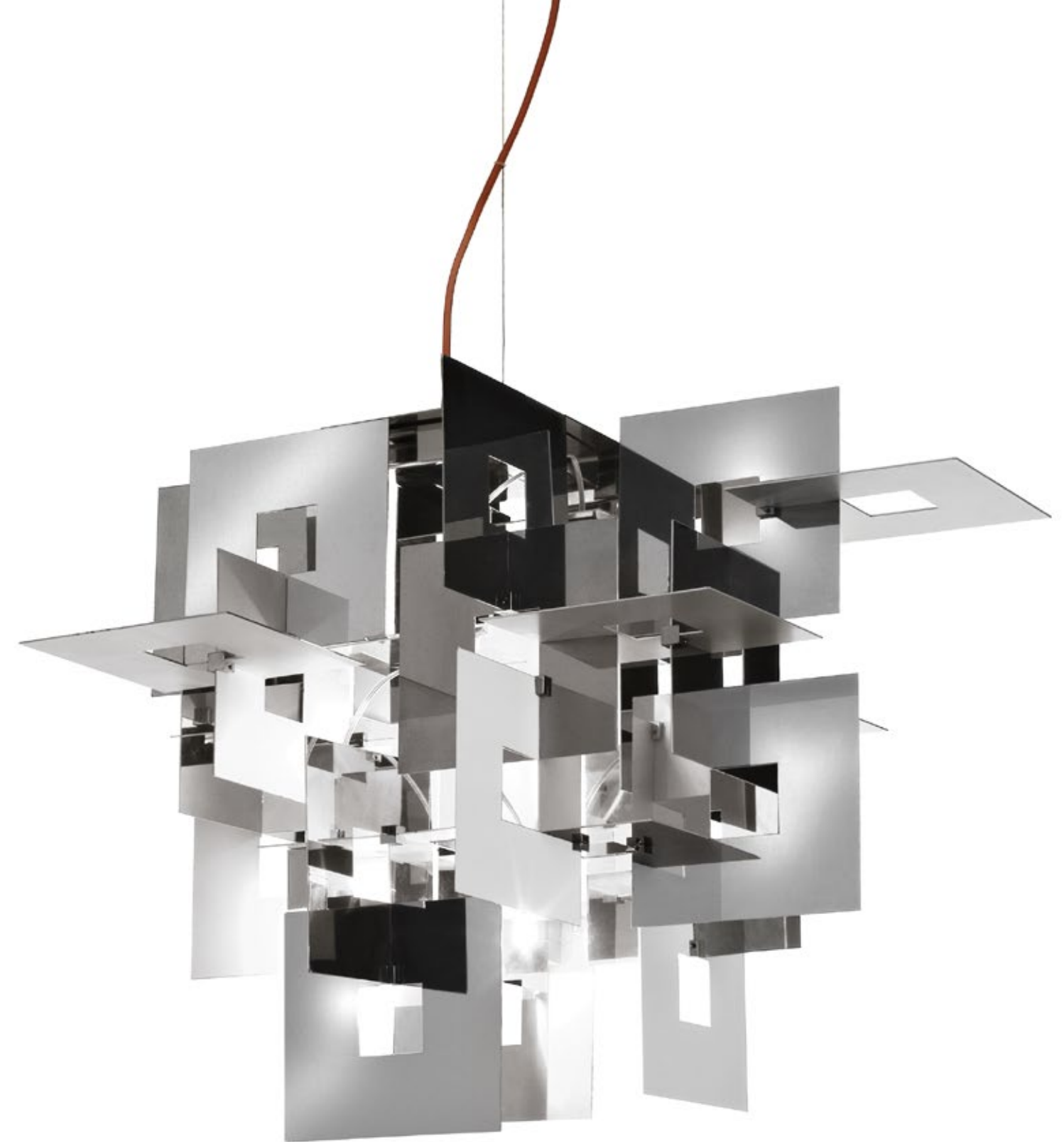



# Hook, an Alluring *Design.*

Hook, comprised of a series of arched arms, creates an enticing light that draws people towards it. Bathing the room in a soft glow, viewers are easily captured by Hook's inviting elegance. Its clean design lends well in a variety of settings, casting a light that is equally suitable in commercial or residential environments. Design Jean François Crochet.





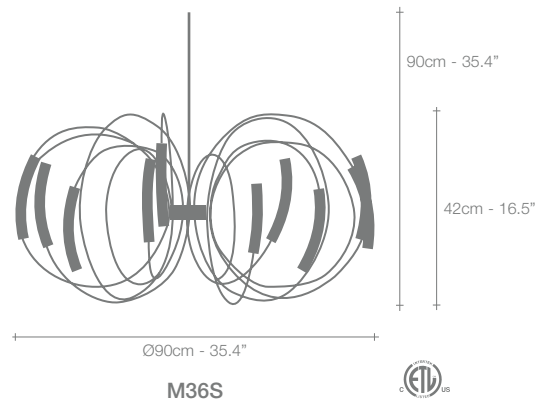

		M36S
230V		HALOGEN 12V G4 12X14W (=12X20W)
120V		XENON BI-PIN 12V T3 G4 12X20W

HOOK CAN BE  
MANUFACTURED TO WORK  
WITH BI-PIN LED LIGHT  
SOURCE ON REQUEST





# Bobino, a Hidden *Illumination.*

The wire-wrapped frame of Bobino encases a simple, clean spotlight, perfect for showcasing a special object or area. Created with over 16 meters of metal wire, this compact design belies an elegant complexity. While perfect in a commercial setting, Bobino's design is equally effective in residential applications. Also available in clear glass. Design Jean François Crochet.





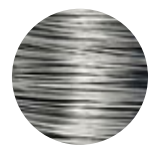
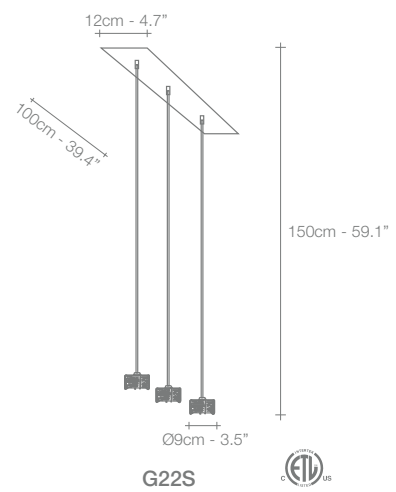
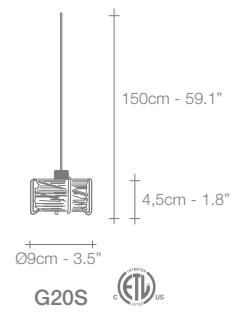
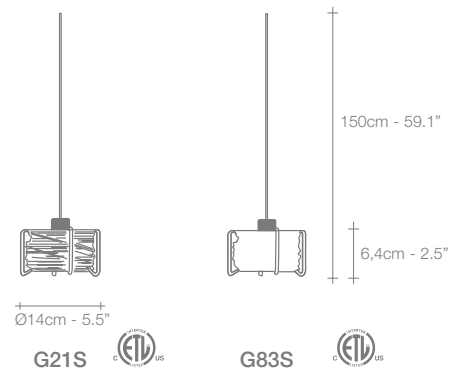

CHROME FINISH  
METAL



CHROME FINISH  
CLEAR GLASS

	G20S G22S		G21S		G83S			
230V		HALOGEN 12V GU4 35W		3X35W		HALOGEN GZ10 50W		HALOGEN ES G9 48W (=60W)
120V		HALOGEN 12V BI-PIN MR11 GU4 35W		3X35W		HALOGEN MR16 GU10 50W		HALOGEN JCD G9 35W





# Zig-Zag, Easy *Sophistication.*

Either alone or a group, Zig-Zag is a truly unique way to add light to any space. Intended to lean nonchalantly against a wall, the soft glow from the notched, Zig-Zag openings creates a comfortable ambience while adding a distinctly progressive design element. Zig-Zag complements rooms with high ceilings while opening up smaller spaces. Design Jean François Crochet.





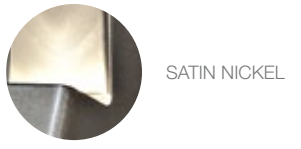
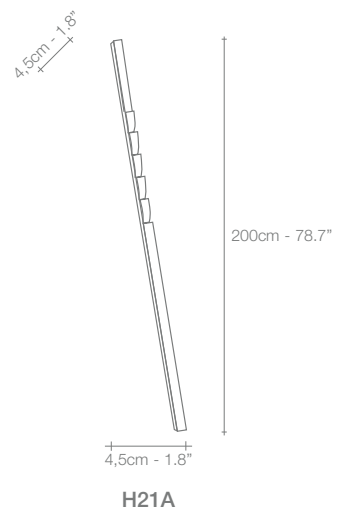
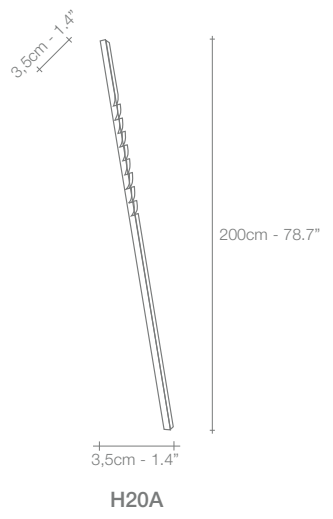

	H20A	H21A
230V	HALOGEN 12V G4	9X5W 6X10W
120V	XENON BI-PIN 12V T3 G4	9X5W 6X10W

ZIG-ZAG CAN BE  
MANUFACTURED TO WORK  
WITH BI-PIN LED LIGHT  
SOURCE ON REQUEST





# Hugo, a Welcome *Guest.*

Some designs are strong enough to stand alone. These are the pieces that transform spaces and inspire viewers. Hugo, a unique sculpture created by Terzani's master craftsmen, is composed of hand-forged metal stems, encasing a single light. With a graceful, delicate form, Hugo is a welcome guest in any space, intriguing and powerful. Design Jean François Crochet.





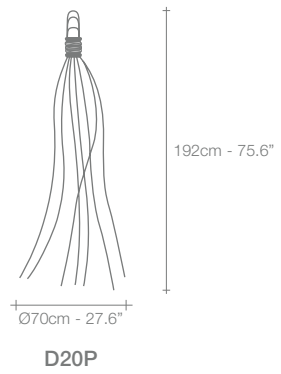

**D20P**

230V HALOGEN ES E27 105W (=150W)

120V HALOGEN ECO A19 E26 72W (=100W)







## Art and *Crafts*

*Terzani has a tradition deeply rooted in Italian craftsmanship. From shaping precious metals to painstakingly constructing every piece, our master craftsmen give attention to every design, resulting in unparalleled quality and a distinct aesthetic.*













**TERZANI**  
LA LUCE PENSATA

All products in Terzani collections are inspired by a return to noble artisan traditions. Every object is carefully created using craft techniques and for this reason certain details may vary from product to product. These variations are not imperfections but characteristic peculiarities of the production process. Terzani reserves the right to modify its products in order to improve its features. The reproduction on paper of products may result in a misrepresentation of some colors. Measurements are in cm and inches. For updated technical data please refer to our current price list or our website. For updates on etl  please visit our website or call our customer service. Etl  certification may be available on request when not listed. All products are CE certified.

**Terzani srl**

Via Castelpulci Int.9  
50018 Firenze Italy  
Ph +39 055 722021  
F +39 055 7311161  
info@terzani.com

**Terzani Usa, Inc.**

11470 Interchange  
Circle North  
Miramar, FL 33025  
Ph 954 438 7779  
F 954-438 7566  
Toll free1 (866) 380-5412  
info@terzaniusa.com

Creative Direction Terzani  
Photos Leonardo Beglieri  
Art Direction Camilla Cordella  
Artwork Terzani  
Photo (pages 24/25) Riccardo Umato  
Digital imaging Art And Pixel  
Eu (Italy) 2015

**terzani.com**

© terzani 2015





**TERZANI**  
LA LUCE PENSATA

[terzani.com](http://terzani.com)