

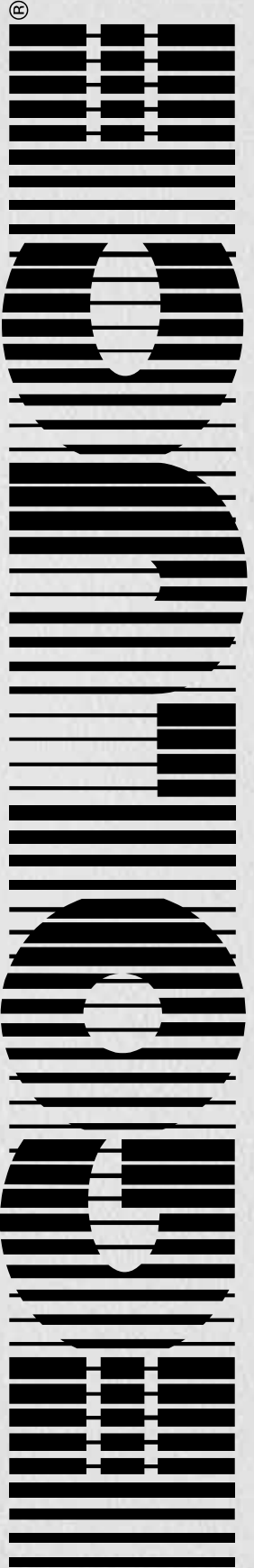

technical
2016 - 2017



Architectural

p. 12

Outdoor

p. 134

Lighting Systems

p. 202

Decorative Lights

p. 280

Spots

p. 334

Technology

p. 406

PIÙ DI 35 ANNI DI MADE IN ITALY

L'Italia è la culla della creatività. La tradizione artigianale e lo stile italiani sono conosciuti e ammirati in tutto il mondo, tanto che il marchio Made in Italy costituisce da sempre un valore aggiunto ambito e ricercato. Un prodotto italiano è immediatamente riconoscibile per la cura dei particolari e i valori estetici che esprime.

Nel solco di questa grande tradizione, dal 1978 EGOLUCE crea prodotti Made in Italy, collaborando con aziende e artigiani italiani per garantire ai propri clienti un prodotto dagli altissimi contenuti tecnologici e di design. La rigorosa selezione qualitativa dei componenti e dei materiali e la lavorazione guidata dai criteri della qualità totale ci consente di produrre e offrire alla clientela una vasta gamma di apparecchi per tutti i tipi di utilizzo. Prodotti dei quali siamo fieri e orgogliosi. **Prodotti Made in Italy.**

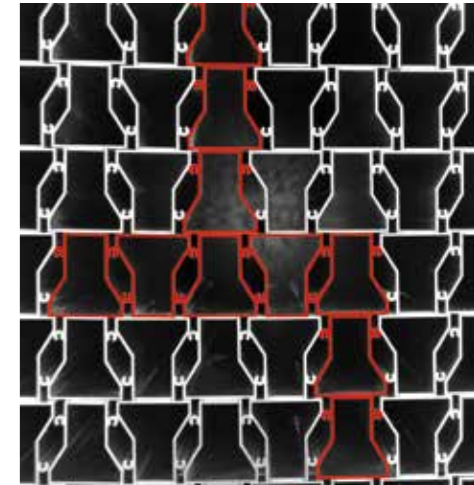

MORE THAN 35 YEARS OF MADE IN ITALY

Italy is the cradle of creativity. Its artisan tradition and style are known and admired throughout the world, so much so that the Made in Italy mark has always constituted sought-after added value. An Italian product can immediately be recognized for the attention to details and the aesthetic values it expresses.

In the wake of this great tradition, since 1978 EGOLUCE has been creating Made in Italy products, mostly collaborating with Italian companies and craftsmen in order to offer its clients a high tech and design product.

The rigorous selection of high-quality components and materials and the processing guided by criteria such as total quality enable us to produce and offer clients a vast range of light fixtures for all types of use.

Products of which we are very proud.

Products Made in Italy.

This catalogue completes the process of transformation of all EGOLUCE technical products into luminaires with/for LED light sources.

Continuous research on newly developing LED technologies, combined with a decade of experience in this specific sector, has led us to this goal with the certainty of offering cutting edge technological solutions while ensuring reliability and durability of our products.

We have decided to abandon comparisons and analogies with the traditional light sources used in the past as performance reference and switch to a new vocabulary made of light parameters which explain precisely the various aspects and increasingly high performances of LED sources.

We have been working with the aim to provide the information in an easy-to-read and understandable way in order to make the technical catalogue EGOLUCE 2017 a valuable tool for light designers all around the world.

With this catalogue we have completed the transformation of all EGOLUCE technical products into luminaires with/for LED light sources.

Continuous research on newly developing LED technologies, combined with a decade of experience in this specific sector, has led us to this goal with the certainty of offering cutting edge technological solutions while ensuring reliability and durability of our products.

We have decided to abandon comparisons and analogies with the traditional light sources used in the past as performance reference and switch to a new vocabulary made of light parameters which explain precisely the various aspects and increasingly high performances of LED sources.

We have been working with the aim to provide the information in an easy-to-read and understandable way in order to make the technical catalogue EGOLUCE 2017 a valuable tool for light designers all around the world.

**PROJECT
YOUR
LIGHT**

Architectural

Lines

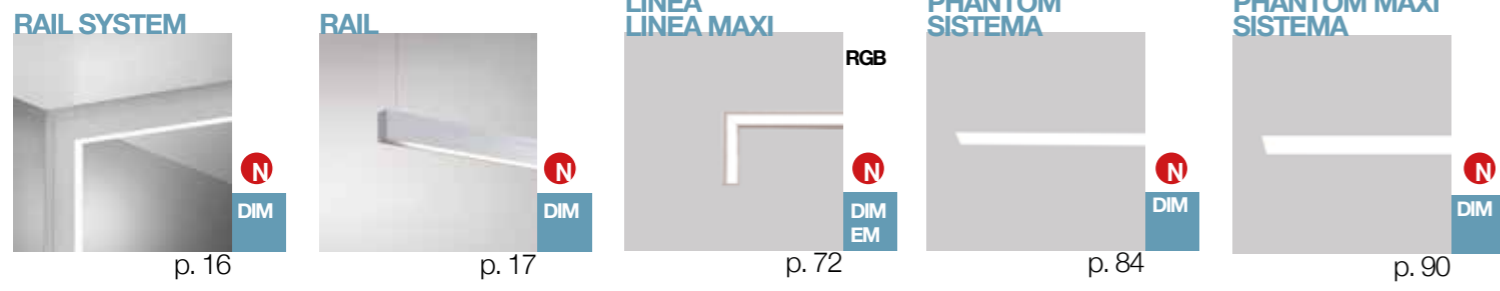

Square

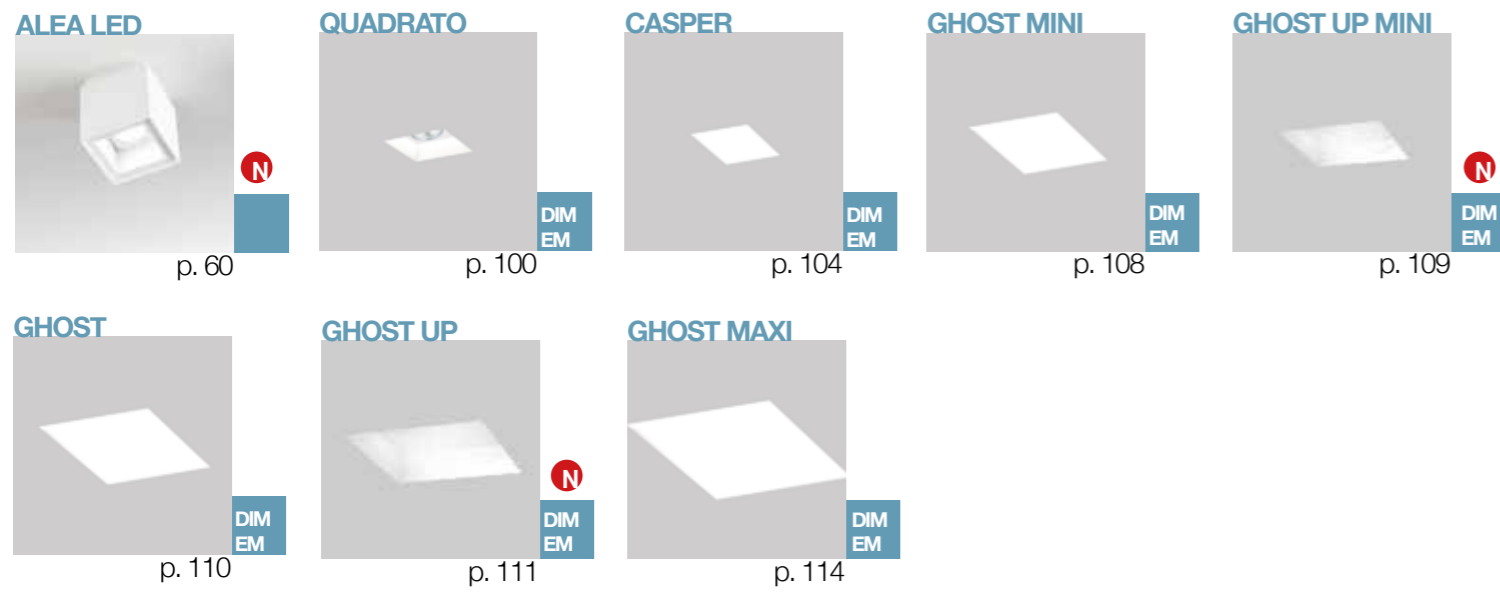

Round

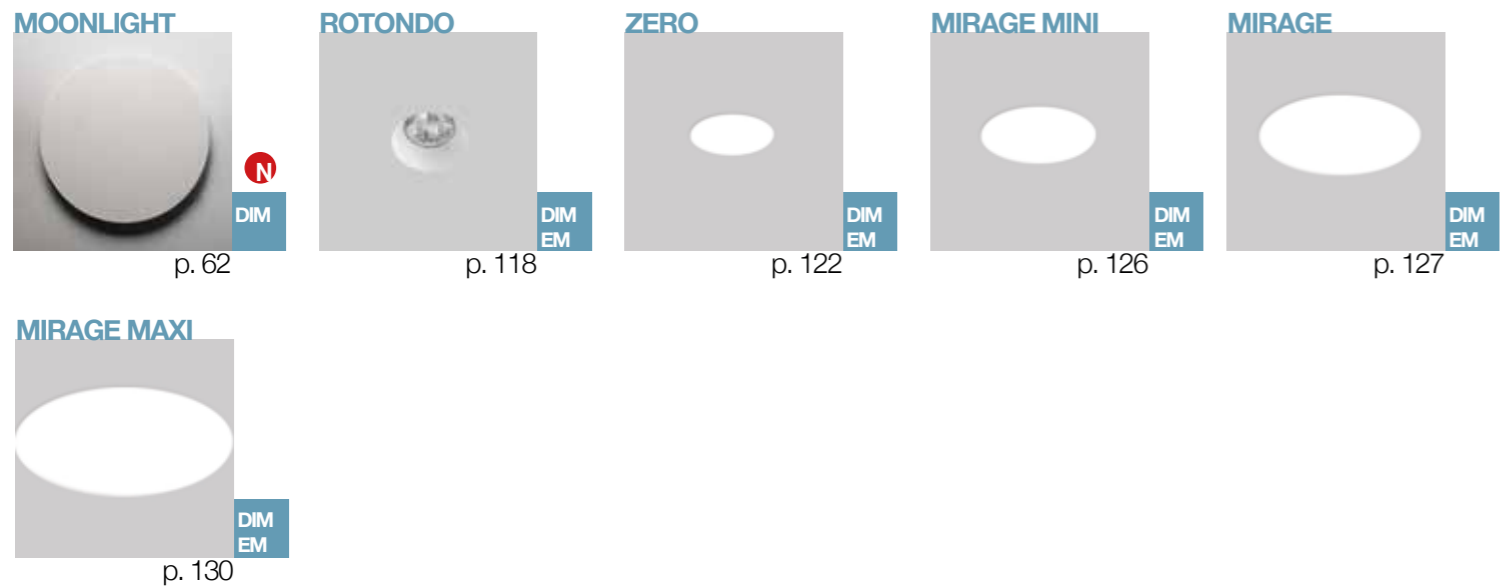

Outdoor

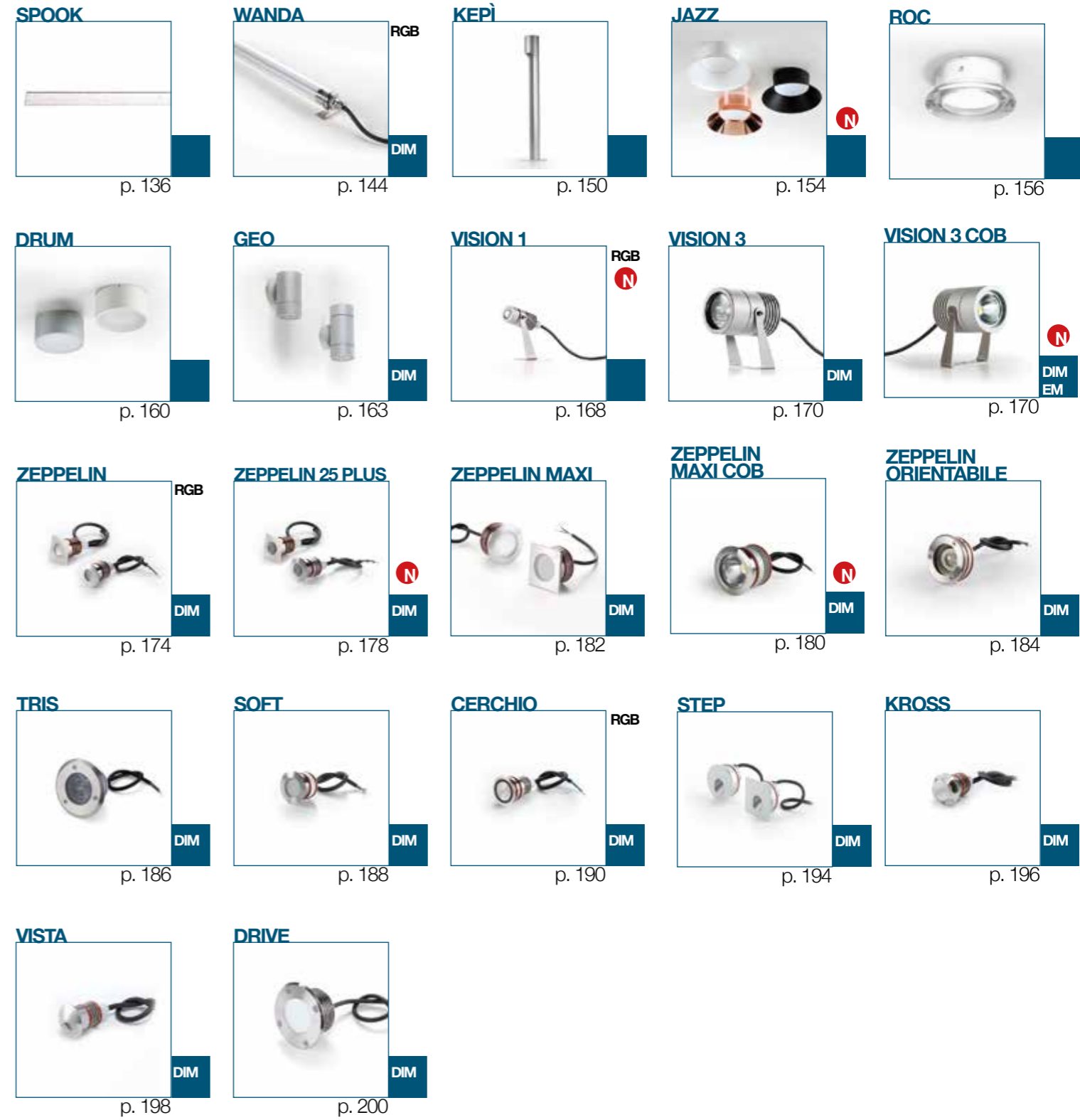

Lighting Systems

Profiles



Projectors



Track Spots



Cable



Decorative Lights

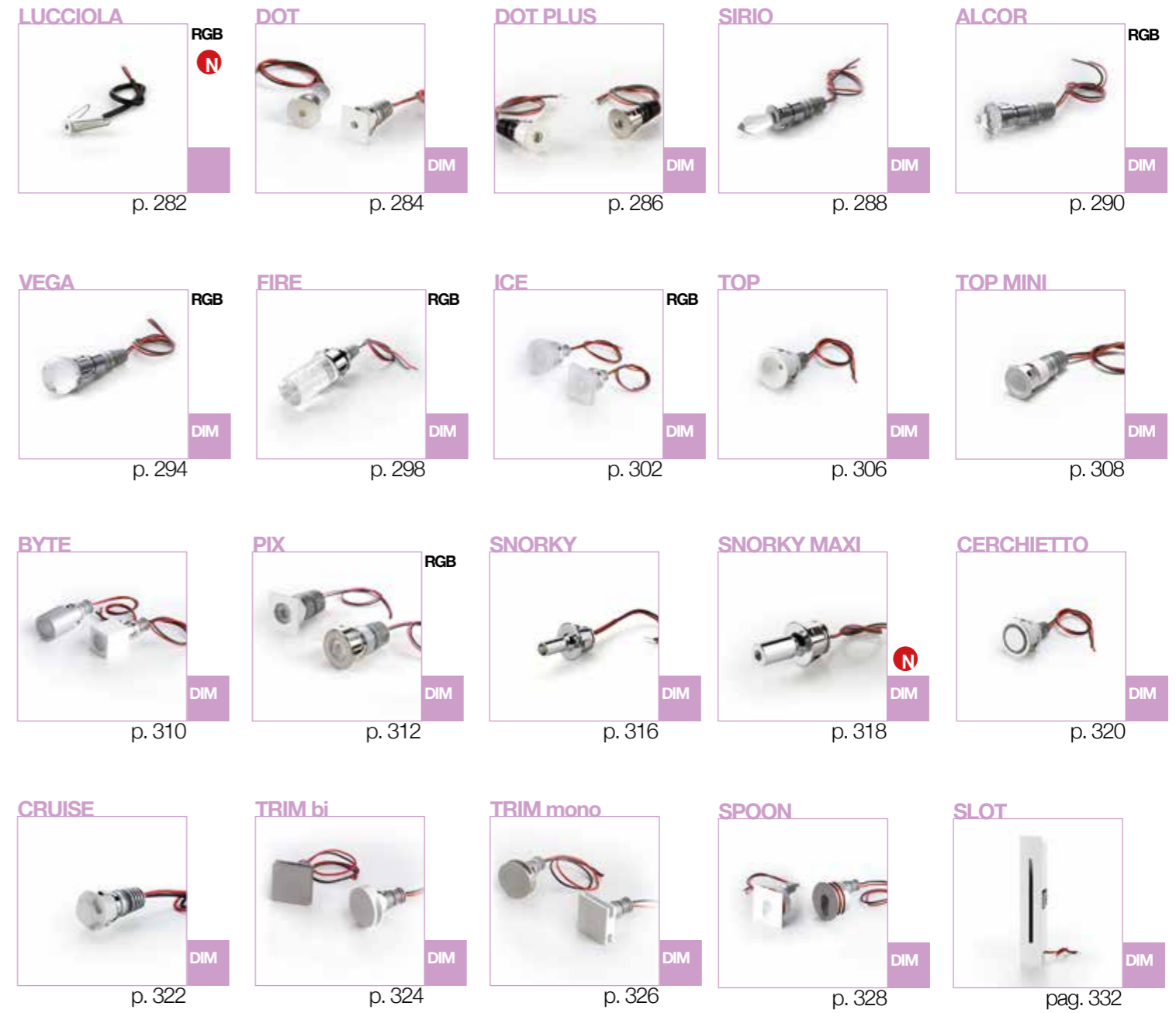

Spots



Square



Round

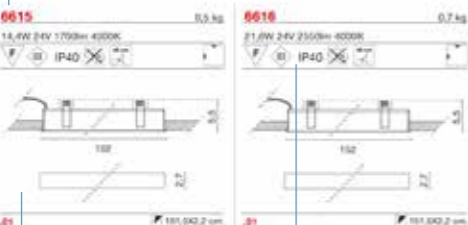
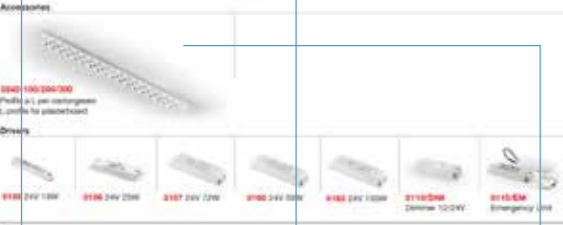

LAYOUT

Capitolo Chapter	Codice Code	Nome Name	Foto Picture	Ambientazione Still Life
LINEA design: U.T. EGOLUICE				
				
				
Disegno Tecnico Technical Drawing	Dati Tecnici Technical Data	Accessori Accessories	Alimentatori Drivers	

I caratteri in rosso sono utilizzati per il codice e le specifiche che concorrono alla definizione del prodotto da indicare negli ordini.

Red characters are used for code and specifications needed to identify the product code to be indicated in orders.

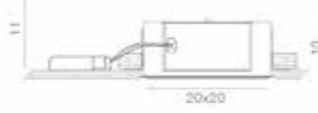
Prodotto Product	6608 ghost led DIMMERABILE 1-10 1,9 kg
Lumen Nominali Gross Lumen Package	15,3W 1750lm 3000°K (WW) 15,3W 1800lm 4000°K (W)
Finitura Finish	.01/W/DIM .01/WW/DIM 70,5x22,5cm
Specifiche Specifications	
Colore luce Light color	

Architectural	12
Lineari-Lines	P. 14
Quadrati-Square	P. 100
Rotondi-Round	P. 118
Outdoor	134
Lineari-Lines	P. 136
Lampade-Lamps	P. 154
Paletti-Bollards	P. 150
Segnali o luci-Signal or spot lights	P. 172
Carrabili-Driveover	P. 200
Lighting Systems	202
Profilì-Profiles	P. 204
Proiettori-Projectors	P. 256
Sistema cavo-Cable	P. 270
Proiettori per Binario-Track Spots	P. 250
Decorative Lights	280
Spots	334
Quadrati-Square	P. 336
Rotondi-Round	P. 364
Tecnology	406
Tecnologie led-Led Technologies	P. 407
Sistemi di controllo Led-Led Control Systems	P. 414
Installazioni-Installations	P. 436
Accessori-Accessories	P. 440
Alimentatori-Drivers	P. 443

Lines

RAIL SISTEMA	p. 18
RAIL	p. 50
LINEA MAXI	p. 72
LINEA	p. 76
LINEA MAXI RGB	p. 80
LINEA RGB	p. 80
PHANTOM	p. 84
PHANTOM MAXI	p. 90
PHANTOM MAXI PLUS	p. 92

Square

ALEA LED	p. 60
QUADRATO	p. 100
CASPER	p. 104
GHOST MINI	p. 108
GHOST UP MINI	p. 109
GHOST	p. 110
GHOST UP	p. 111
GHOST MAXI	p. 114

Round

MOONLIGHT	p. 62
ROTONDO	p. 118
ZERO	p. 122
MIRAGE MINI	p. 126
MIRAGE	p. 127
MIRAGE MAXI	p. 130

ARCHITECTURAL

RAIL SYSTEM - RAIL

design: U.T. EGOLUCE

Architectural

Architectural

Un modo diverso d'interpretare la luce. Un sistema lineare continuo LED che, allo stesso tempo, diventa uno strumento decorativo per disegnare e ridefinire lo spazio. La modularità degli elementi permette di realizzare molteplici configurazioni luminose senza ombre o interruzioni.

È possibile disegnare linee, angoli ed incroci di luce su di un unico piano o tra piani diversi (parete/soffitto, parete/sospensione, incasso).

Questo rende RAIL un sistema estremamente versatile che si presta per una vasta gamma di installazioni sia in ambienti privati che pubblici.

A different way to interpret lighting. An endless linear LED lighting system that becomes at the same time a decorative instrument to define and re-design spaces. The availability of a wide range of modular elements allows to design a number of compositions without any light interruption or shade.

It is possible to draw lines and angles of light on single or multiple planes (Ceiling/wall, wall/suspension, recessed). This makes RAIL an extremely versatile fixture that fits for a vast range of installations both in private and public spaces.

Une façon différente d'interpréter la lumière. Un système linéaire LED qui devient au même temps un instrument décoratif pour dessiner et redéfinir l'espace.

La modularité des éléments permet de réaliser nombreuses configurations lumineuses sans ombres ou interruptions.

On peut dessiner des lignes avec coins et croisements de lumière sur un seul ou plusieurs plans (mur/plafond, mur/suspension, encastré).

Tout ça rend RAIL un appareil extrêmement flexible qui bien s'adapte pour nombreux projets soit dans d'espaces publics ou privés.

Einen unterschiedliche Interpretation der Licht.

Ein lineares LED Beleuchtungssystem, die gleichzeitig eine dekorative Instrument für Raumdesign ist.

Dank die Modularität von verschiedene Elemente, kann man mehrere endlose Kompositionen ohne Schatten oder Unterbrechungen realisieren.

Man kann einfach Lichtlinien mit Winkeln und Kreuzungen zusammensetzen auf eine oder mehrere Oberflächen (Wand/Decke, Wand/Pendel, Einbau).

Auf diesem Grund ist RAIL eine sehr vielseitige Leuchte, die für viele Installationen in Öffentliche- sowie in Privatbereich sehr gut passt.

Una interpretación diferente de la luz. Un sistema linear LED que, al mismo tiempo, se convierte en instrumento decorativo para diseñar y redefinir el espacio.

La modularidad de sus elementos permite de realizar numerosas configuraciones luminosas sin alguna sombra o interrupción.

Se pueden diseñar líneas con esquinas y cruces sur uno o mas planos (techo/pared, pared/suspension, empotrado).

Todo esto hace de RAIL un sistema muy versátiles adapto por varias instalaciones también en espacios públicos y privados.

новый подход к освещению. Бесконечная линейная светодиодная система, которая может стать одновременно функциональным и декоративным элементом способным изменить дизайн помещения.

Разнообразие элементов для дизайна световой системы позволяет создавать множество световых композиций избегая темных участков.

Можно создавать световые линии, угловые переходы в одной или нескольких плоскостях (стена/потолок, стена/подвес, встройка). Это делает RAIL чрезвычайно гибкой системой, которую можно адаптировать как к частным, так и к общественным интерьерам.

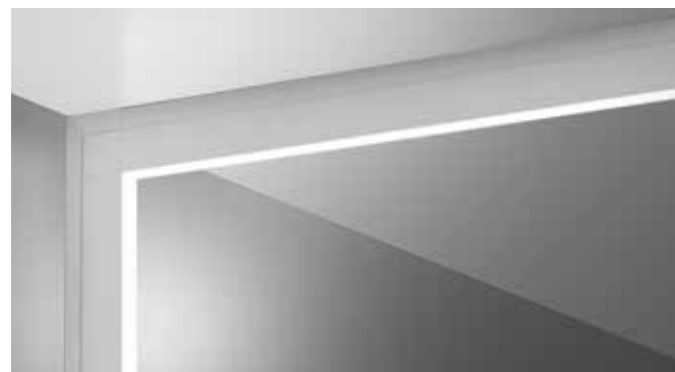

Soffitto - Parete
Ceiling - Wall

p. 18



Sospensione
Suspension

p. 50



Sospensione
Suspension

p. 26



Sospensione Biemissione
Suspension Double emission

p. 54



Parete (Luce radente)
Wall (Grazing light)

p. 34



Parete (Luce radente)
Wall (Grazing light)

p. 56

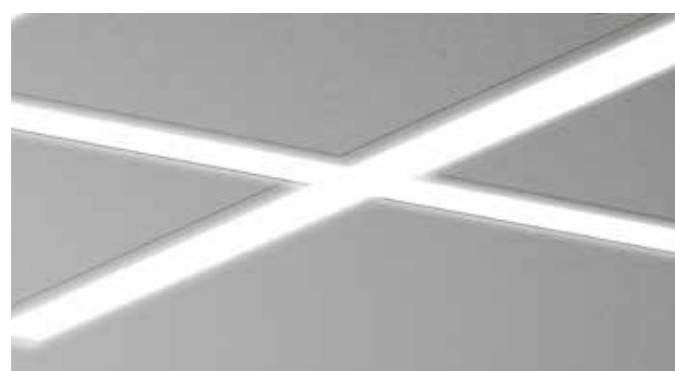

Incasso
Recessed

p. 42



Soffitto - Parete
Ceiling - Wall

p. 58

RAIL SYSTEM CEILING/WALL

design: U.T. EGOLUCE

Sistema modulare soffitto/parete per luce diffusa. Profilo in alluminio estruso verniciato bianco opaco RAL 9016 (a richiesta nero semi opaco RAL 9005).

Testate in metacrilato stampato e verniciato bianco.

Gli apparecchi sono completi di circuito LED, converter interno, elementi di giunzione e particolari adesivi per mascherare eventuali sbaffi di luce indesiderati.

Da ordinare separatamente: il diffusore in polycarbonato satinato e le testate di chiusura.

Gli elementi lineari sono disponibili in varie lunghezze da 60 fino a 300 cm con modularità ogni 10 cm (vedi tabella) a cui si aggiungono giunzioni angolari 90°, a T, o a croce.

Il sistema consente di realizzare grandi configurazioni partendo da un unico punto di alimentazione.

LED disponibili in bianco 2700K, 3000K o 4000K.

A richiesta sono fornibili anche altre tonalità di luce o potenze.

Ceiling/wall modular system for diffused lighting. Profile in extruded aluminum matt white finish RAL 9016 (semi-matt black RAL 9005 upon request).

End pieces in white painted molded methacrylate.

Fixtures are complete with onboard converter, joints and special patches to mask any unwanted light scatter.

To be ordered separately: satin polycarbonate diffuser and the end pieces.

Linear elements are available in different lengths from 60 to 300 cm with a 10 cm modularity (see table). Joints: 90° Angle, T shaped and cross shaped.

The system allows the realization of wide compositions starting from a single power outlet.

LED are available in white 2700K, 3000K, 4000K.

Other light tones and powers can be supplied on request.

Système modulaire mur/plafond pour lumière diffuse. Profil en aluminium extrudé verni blanc mat RAL9016 (noir demi mat RAL9005 sur requête).

Terminales en méthacrylate moulé verni blanc.

Les appareils sont complets de circuit LED, convertisseurs intégrés, joints et adhésives spécifiques pour masquer des éventuelles fuites de lumière.

À commander séparément: diffuseur en polycarbonate satiné et terminales.

Les éléments linéaires sont disponibles en différentes longueurs de 60 à 300cm avec modularité 10cm (voir table). Joints disponibles: Angle 90°, en forme de T et croix.

Le système permet de créer des grandes configurations à partir d'un seul point d'alimentation.

Trois tonalité de lumière disponibles: 2700, 3000 ou 4000K.

D'autres tonalités de lumière et puissances sont disponibles à la demande.

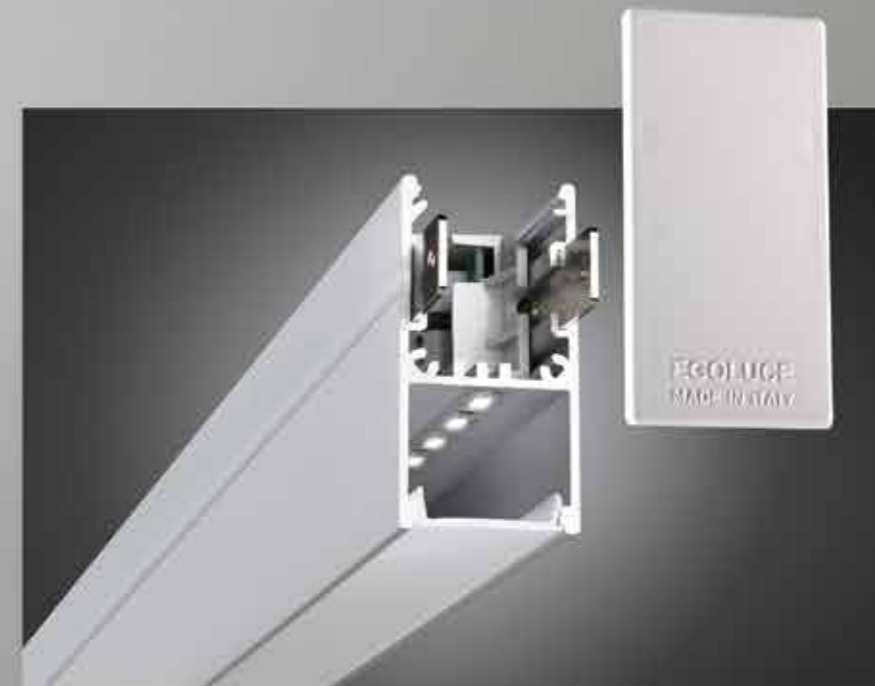

Modular Wand-/Deckenleuchten-System für diffuses Licht. Profil aus stranggepresstem Aluminium matt weiß lackiert RAL 9016 (auf Anfrage halbmatt schwarz RAL 9005).

Endteile aus weiß lackiertem Methacrylat. Die Beleuchtungskörper sind komplett mit LED Platten, 'on board' Konverter, Verbindungsteile und besondere Aufklebern, der eventuelle unerwünschte Lichtflecken entfernen.

Separat zu bestellen: Diffusor aus satiniertem Methacrylat und Endteile.

Die einzelnen Lichtsegmente sind in verschiedene Länge von 60 bis 300cm vorgestellt; Modularität je 10 cm (siehe Tabelle). Zubehör: Ecke 90°, T-förmige Verbinder, Kreuz-verbinder.

Von einen einzelne Stromversorgung Punkt kann man Größe Konfigurationen zusammenfügen.

Drei Lichttonen verfügbar: 2700, 3000 oder 4000K.

Auf Anfrage sind andere Lichttonen oder Leistungen verwendbar.

Sistema modular Techo/pared para luz difusa. Perfil en aluminio extruido pintado blanco mate RAL 9016 (a pedido se hace en Negro semimate RAL 9005).

Finales de metacrilato moldeado pintado blanco.

Los aparatos incluyen placas de LED, convertidor integrado, enganches, y autoadhesivos para eliminar manchas de luz no deseadas.

A pedir por separado: difusor de metacrilato satinado y terminales.

Los elementos lineares se proponen en diferentes longitudes desde 60 hasta 300 cm, modularidad cada 10 cm (ver tabla).

Accesorios: esquina 90°, conector a T, conector a cruz.

El sistema permite de crear configuraciones muy grandes a partir de un único punto de alimentación.

Tres temperaturas de luz disponibles: 2700, 3000 y 4000K.

A pedido se realizan aparatos con otras temperaturas de luz y potencia.

Потолочная/настенная модульная система для равномерного диффузного света. Профиль из экструдированного алюминия или окрашенный в матовый белый цвет RAL 9016 или полуматовый черный RAL 9005 (изготавливается по запросу). Формованные заглушки из матового метакрилата окрашены в белый цвет. Блок питания внутри профиля, переходники тросы и специальные экраны для избавления от нежелательного рассеянного света.

Отдельно заказываются: рассеиватели из сатинированного поликарбоната и заглушки.

Линейные элементы доступны в различных длинах от 60 до 300 см с шагом 10 см (см. таблицу длин). Соединители: угловые 90°, T и X – образные. Можно создавать широкий набор композиций, запитанных из одной точки. Цветовая температура светодиодного модуля: 2700K, 3000K или 4000K. Светильники с другой цветовой температурой могут быть изготовлены по запросу.

RAIL SYSTEM CEILING/WALL

design: U.T. EGOLUCE

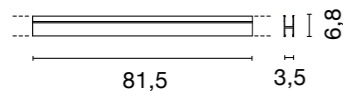

5542 1,1 kg

/xw Led 12W 1424lm 2700K

/ww Led 12W 1520lm 3000K

/w Led 12W 1600lm 4000K



.01/XW .01/WW .01/W

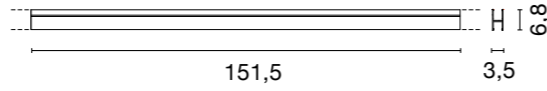

5543 1,5 kg

/xw Led 22,5W 2670lm 2700K

/ww Led 22,5W 2850lm 3000K

/w Led 22,5W 3000lm 4000K



.01/XW .01/WW .01/W

CUSTOM SIZE - Tabella lunghezze disponibili a richiesta. Table of available lengths on request.

cm.	watt	2700K (XW)	lm	3000K (WW)	lm	4000K (W)	lm
61,5	9W	A5542.01/60/XW	1068	A5542.01/60/WW	1140	A5542.01/60/W	1200
71,5	10,5W	A5542.01/70/XW	1246	A5542.01/70/WW	1330	A5542.01/70/W	1400
★ 81,5	12W	5542.01/XW	1424	5542.01/WW	1520	5542.01/W	1600
91,5	13,5W	A5542.01/90/XW	1602	A5542.01/90/WW	1710	A5542.01/90/W	1800
101,5	15W	A5542.01/100/XW	1780	A5542.01/100/WW	1900	A5542.01/100/W	2000
111,5	16,5W	A5542.01/110/XW	1958	A5542.01/110/WW	2090	A5542.01/110/W	2200
121,5	18W	A5542.01/120/XW	2136	A5542.01/120/WW	2280	A5542.01/120/W	2400
131,5	19,5W	A5542.01/130/XW	2314	A5542.01/130/WW	2470	A5542.01/130/W	2600
141,5	21W	A5542.01/140/XW	2492	A5542.01/140/WW	2660	A5542.01/140/W	2800
★ 151,5	22,5W	5543.01/XW	2670	5543.01/WW	2850	5543.01/W	3000
161,5	24W	A5542.01/160/XW	2848	A5542.01/160/WW	3040	A5542.01/160/W	3200
171,5	25,5W	A5542.01/170/XW	3026	A5542.01/170/WW	3230	A5542.01/170/W	3400
181,5	27W	A5542.01/180/XW	3204	A5542.01/180/WW	3420	A5542.01/180/W	3600
191,5	28,5W	A5542.01/190/XW	3382	A5542.01/190/WW	3618	A5542.01/190/W	3800
201,5	30W	A5542.01/200/XW	3560	A5542.01/200/WW	3800	A5542.01/200/W	4000
211,5	31,5W	A5542.01/210/XW	3738	A5542.01/210/WW	3990	A5542.01/210/W	4200
221,5	33W	A5542.01/220/XW	3916	A5542.01/220/WW	4180	A5542.01/220/W	4400
231,5	34,5W	A5542.01/230/XW	4094	A5542.01/230/WW	4370	A5542.01/230/W	4600
241,5	36W	A5542.01/240/XW	4272	A5542.01/240/WW	4560	A5542.01/240/W	4800
251,5	37,5W	A5542.01/250/XW	4450	A5542.01/250/WW	4750	A5542.01/250/W	5000
261,5	39W	A5542.01/260/XW	4628	A5542.01/260/WW	4940	A5542.01/260/W	5200
271,5	40,5W	A5542.01/270/XW	4806	A5542.01/270/WW	5130	A5542.01/270/W	5400
281,5	42W	A5542.01/280/XW	4984	A5542.01/280/WW	5320	A5542.01/280/W	5600
291,5	43,5W	A5542.01/290/XW	5162	A5542.01/290/WW	5510	A5542.01/290/W	5800
301,5	45W	A5542.01/300/XW	5340	A5542.01/300/WW	5700	A5542.01/300/W	6000

★ Articolo standard a catalogo - Standard catalogue item

Accessories



Angolo 90° - 90° Corner

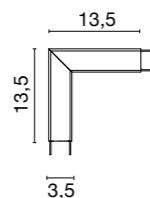

0941 0,4 kg

/xw Led 3W 356lm 2700K

/ww Led 3W 380lm 3000K

/w Led 3W 400lm 4000K



.01/XW .01/WW .01/W



2 testate di chiusura.
2 closing heads.

0945

.01



Giunzione a T - T joint

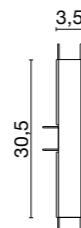

0942 0,35kg

/xw Led 4,5W 534lm 2700K

/ww Led 4,5W 570lm 3000K

/w Led 4,5W 600lm 4000K



.01/XW .01/WW .01/W



Diffusore - Diffuser

0948/200

L. 200cm

0948/300

L. 300cm



Giunzione a croce - Cross joint

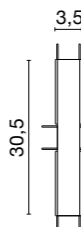

0943 0,35 kg

/xw Led 4,5W 534lm 2700K

/ww Led 4,5W 570lm 3000K

/w Led 4,5W 600lm 4000K



.01/XW .01/WW .01/W



Raccordo parete - plafone
Wall - ceiling joint



0944 0,15 kg

.01

RAIL SYSTEM CEILING/WALL

design: U.T. EGOLUCE

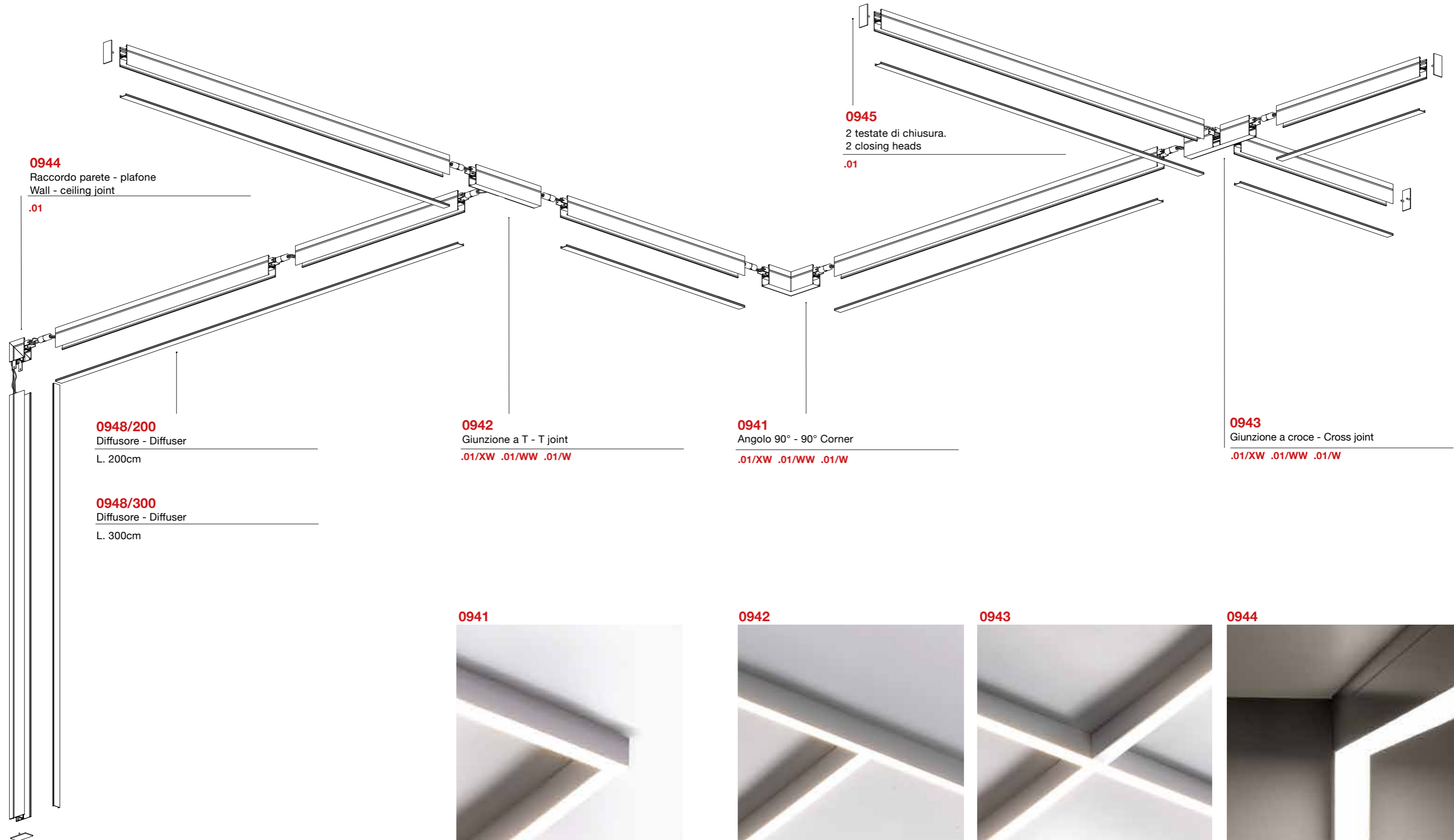

RAIL SYSTEM CEILING/WALL

design: U.T. EGOLUCE

Architectural



RAIL SYSTEM SUSPENSION

design: U.T. EGOLUCE

Sistema modulare sospeso per luce diffusa. Profilo in alluminio estruso verniciato bianco opaco RAL 9016 (nero semiopaco RAL 9005 a richiesta).

Testate in metacrilato stampato e verniciato bianco.

Gli apparecchi sono completi di circuito LED, converter interno, elementi di giunzione, cavi d'acciaio regolabili e particolari adesivi per mascherare eventuali sbaffi di luce indesiderati.

Da ordinare separatamente: il diffusore in policarbonato satinato, il rosone a soffitto e le testate di chiusura.

Gli elementi lineari sono disponibili in varie lunghezze da 60 fino a 300 cm con modularità ogni 10 cm (vedi tabella) a cui si aggiungono giunzioni angolari 90°, a T, o a croce.

Il sistema consente di realizzare grandi configurazioni partendo da un unico punto di alimentazione.

Tre toni di luce disponibili: 2700, 3000 o 4000K.

A richiesta sono fornibili altre tonalità di luce o potenze.

Suspended modular system for diffused lighting. Profile in extruded aluminum, matt white finish RAL 9016 (semi-matt black RAL 9005 upon request). End pieces in white painted molded methacrylate.

Fixtures are complete with onboard converter, joints, adjustable steel ropes and special patches to mask any unwanted light scatter.

To be ordered separately: satin polycarbonate diffusers, ceiling rose and the end pieces.

Linear elements are available in different lengths from 60 to 300 cm with a 10 cm modularity (see table). Available joints: 90° Angle, T shaped and cross shaped.

The system allows the realization of wide compositions starting from a single power outlet.

Three light tones available: 2700, 3000, 4000K.

Other light tones and powers can be supplied on request.

Système modulaire suspendu pour lumière diffuse. Profil en aluminium extrudé verni blanc mat RAL 9016 (noir demi mat RAL 9005 sur requête). Terminales en méthacrylate moulé

Les appareils sont complets de circuit LED, convertisseurs intégré, joints, câbles réglables en acier et adhésives spécifiques pour masquer des éventuelles fuites de lumière.

À commander séparément: diffuseur en polycarbonate satiné, rosace et terminales.

Les éléments linéaires sont disponibles en différentes longueurs de 60 à 300 cm avec modularité 10 cm (voir table). Joints disponibles: Angle 90°, en forme de T et croix.

Le système permet de créer des grandes configurations à partir d'un seul point de alimentation.

Trois tonalités de lumière disponibles: 2700, 3000 ou 4000K.

D'autres tonalités de lumière et puissances sont disponibles à la demande.

Modular Pendelleuchten-System für diffuses Licht. Profil aus stranggepresstem Aluminium matt weiß lackiert RAL 9016 (auf Anfrage halbmatt schwarz RAL9005).

Endteile aus weiß lackiertem Methacrylat. Die Beleuchtungskörper sind komplett mit LED Platten, 'on board' Konverter, Verbindungsteile und besondere Aufklebern, der eventuelle unerwünschte Lichtflecken entfernen.

Separat zu bestellen: Diffusor aus satiniertem Methacrylat, Baldachin und Endteile. Die einzelnen Lichtsegmente sind in verschiedene Länge von 60 bis 300cm vorgestellt; Modularität je 10 cm (siehe Tabelle) Zubehör: Ecke 90°, T-förmige Verbinder, Kreuz-verbinder.

Von einen einzelne Stromversorgung Punkt kann man Größe Konfigurationen zusammenfügen.

Drei Lichttonen verfügbar: 2700, 3000 oder 4000K.

Auf Anfrage sind andere Lichttonen oder Leistungen verwendbar.

Sistema modular suspendido para luz difusa. Perfil en extrusión de aluminio pintado blanco mate RAL 9016 (a pedido se hace en Negro semimate RAL 9005).

Finales de metacrilato moldeado pintado blanco.

Los aparatos incluyen placas de LED, convertidor integrado, enganches y autoadhesivos para eliminar manchas de luz no deseadas.

A pedir por separado: difusor de metacrilato satinado, floron y terminales.

Los elementos lineares se proponen en diferentes longitudes desde 60 hasta 300 cm, modularidad cada 10 cm (ver tabla).

Acesorios: esquina 90°, conector a T, conector a cruz.

El sistema permite de crear configuraciones muy grandes a partir de un único punto de alimentación

Tres temperaturas de luz disponibles: 2700, 3000 y 4000K.

A pedido se relizan aparatos con otras temperaturas de luz y potencia.

Подвесная модульная система для равномерного диффузного света.

Профиль из экструдированного алюминия или окрашенный в матовый белый цвет RAL 9016 или полуматовый черный RAL 9005 (изготавливается по запросу). Формованные заглушки из матового метакрилата окрашены в белый цвет. Блок питания внутри профиля, переходники, регулируемые стальные тросы и специальные экраны для предотвращения нежелательного рассеянного света.

Отдельно заказываются: рассеиватели из сатинированного поликарбоната, потолочная база и заглушки.

Линейные элементы доступны в различных длинах от 60 до 300 см с шагом 10 см (см. таблицу длин). Соединители: угловые 90°, T и X – образные. Можно создавать широкий набор композиций, запитанных из одной точки. Цветовая температура светодиодного модуля: 2700K, 3000K или 4000K. Светильники с другой цветовой температурой могут быть изготовлены по запросу.



RAIL SYSTEM SUSPENSION

design: U.T. EGOLUCE

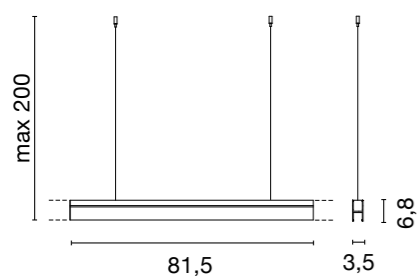

1543 1 kg

/XW Led 12W 1424lm 2700K

/WW Led 12W 1520lm 3000K

/W Led 12W 1600lm 4000K



.01/XW .01/WW .01/W



1544 1,4 kg

/XW Led 22,5W 2670lm 2700K

/WW Led 22,5W 2850lm 3000K

/W Led 22,5W 3000lm 4000K



.01/XW .01/WW .01/W

CUSTOM SIZE - Tabella lunghezze disponibili a richiesta. Table of available lengths on request.

cm.	watt	2700K (XW)	lm	3000K (WW)	lm	4000K (W)	lm
61,5	9W	A1543.01/60/XW	1068	A1543.01/60/WW	1140	A1543.01/60/W	1200
71,5	10,5W	A1543.01/70/XW	1246	A1543.01/70/WW	1330	A1543.01/70/W	1400
* 81,5	12W	1543.01/XW	1424	1543.01/WW	1520	1543.01/W	1600
91,5	13,5W	A1543.01/90/XW	1602	A1543.01/90/WW	1710	A1543.01/90/W	1800
101,5	15W	A1543.01/100/XW	1780	A1543.01/100/WW	1900	A1543.01/100/W	2000
111,5	16,5W	A1543.01/110/XW	1958	A1543.01/110/WW	2090	A1543.01/110/W	2200
121,5	18W	A1543.01/120/XW	2136	A1543.01/120/WW	2280	A1543.01/120/W	2400
131,5	19,5W	A1543.01/130/XW	2314	A1543.01/130/WW	2470	A1543.01/130/W	2600
141,5	21W	A1543.01/140/XW	2492	A1543.01/140/WW	2660	A1543.01/140/W	2800
* 151,5	22,5W	1544.01/XW	2670	1544.01/WW	2850	1544.01/W	3000
161,5	24W	A1543.01/160/XW	2848	A1543.01/160/WW	3040	A1543.01/160/W	3200
171,5	25,5W	A1543.01/170/XW	3026	A1543.01/170/WW	3230	A1543.01/170/W	3400
181,5	27W	A1543.01/180/XW	3204	A1543.01/180/WW	3420	A1543.01/180/W	3600
191,5	28,5W	A1543.01/190/XW	3382	A1543.01/190/WW	3618	A1543.01/190/W	3800
201,5	30W	A1543.01/200/XW	3560	A1543.01/200/WW	3800	A1543.01/200/W	4000
211,5	31,5W	A1543.01/210/XW	3738	A1543.01/210/WW	3990	A1543.01/210/W	4200
221,5	33W	A1543.01/220/XW	3916	A1543.01/220/WW	4180	A1543.01/220/W	4400
231,5	34,5W	A1543.01/230/XW	4094	A1543.01/230/WW	4370	A1543.01/230/W	4600
241,5	36W	A1543.01/240/XW	4272	A1543.01/240/WW	4560	A1543.01/240/W	4800
251,5	37,5W	A1543.01/250/XW	4450	A1543.01/250/WW	4750	A1543.01/250/W	5000
261,5	39W	A1543.01/260/XW	4628	A1543.01/260/WW	4940	A1543.01/260/W	5200
271,5	40,5W	A1543.01/270/XW	4806	A1543.01/270/WW	5130	A1543.01/270/W	5400
281,5	42W	A1543.01/280/XW	4984	A1543.01/280/WW	5320	A1543.01/280/W	5600
291,5	43,5W	A1543.01/290/XW	5162	A1543.01/290/WW	5510	A1543.01/290/W	5800
301,5	45W	A1543.01/300/XW	5340	A1543.01/300/WW	5700	A1543.01/300/W	6000

* Articolo standard a catalogo - Standard catalogue item

Accessories



Angolo 90° - 90° Corner

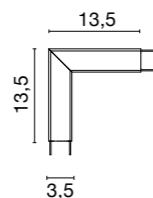

0941 0,4 kg

/XW Led 3W 356lm 2700K

/WW Led 3W 380lm 3000K

/W Led 3W 400lm 4000K



.01/XW .01/WW .01/W



Giunzione a T - T joint

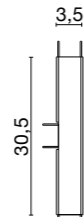

0942 0,35kg

/XW Led 4,5W 534lm 2700K

/WW Led 4,5W 570lm 3000K

/W Led 4,5W 600lm 4000K



.01/XW .01/WW .01/W



Giunzione a croce - Cross joint

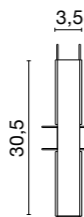

0943 0,35 kg

/XW Led 4,5W 534lm 2700K

/WW Led 4,5W 570lm 3000K

/W Led 4,5W 600lm 4000K



.01/XW .01/WW .01/W



Raccordo parete - plafone
Wall - ceiling joint

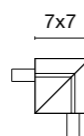

0944 0,15 kg

.01



2 testate di chiusura.
2 closing heads.

0945

.01



Rosone completo di cavo
di alimentazione
Ceiling rose with
cable

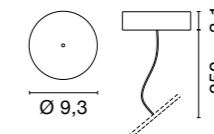

0946 0,08 kg

.01



Piastra con molle per controsoffitti
Ceiling plate with springs

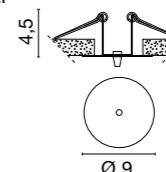

0947 0,07 kg

.01

⌀ 7,5 cm.



Diffusore - Diffuser

0948/200

L. 200cm

0948/300

L. 300cm

RAIL SYSTEM SUSPENSION

design: U.T. EGOLUCE

Architectural

Architectural

0944
Raccordo parete - plafone
Wall - ceiling joint
.01

0947
Piastra con molle per controsoffitti
Ceiling plate with springs
.01

0946
Rosone completo di cavo di alimentazione
Ceiling rose with cable
.01

0941 Angolo 90° - 90° Corner
.01/XW .01/WW .01/W

0942 Giunzione a T - T joint
.01/XW .01/WW .01/W

0943 Giunzione a croce - Cross joint
.01/XW .01/WW .01/W

0948/200 Diffusore - Diffuser
L. 200cm

0948/300 Diffusore - Diffuser
L. 300cm

0945
2 testate di chiusura.
2 closing heads
.01

0941



0942



0943



0944



RAIL SYSTEM SUSPENSION

design: U.T. EGOLUCE

Architettura

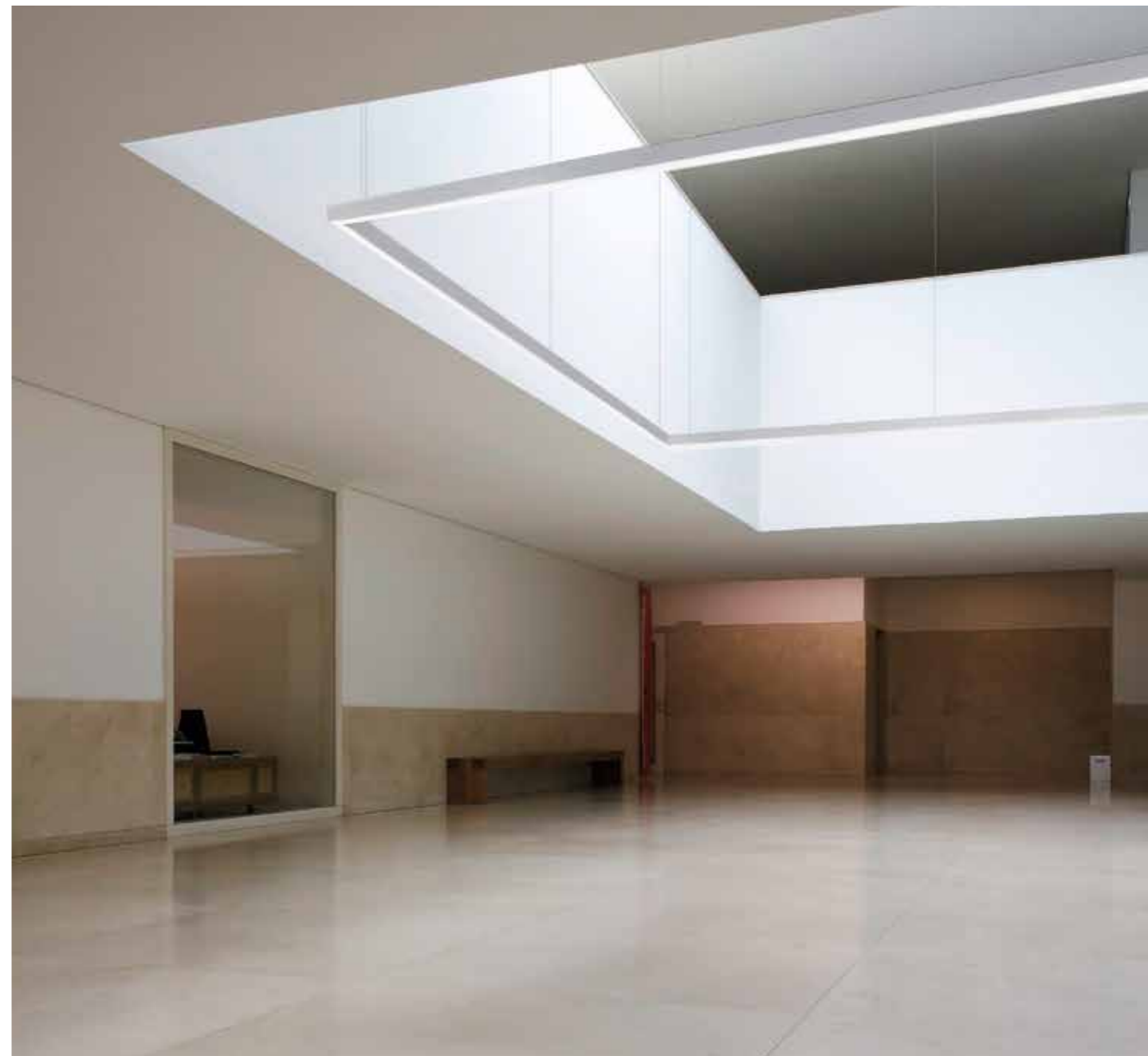

33

RAIL SYSTEM WALL (luce radente/grazing light)

design: U.T. EGOLUCE

Sistema modulare a parete per luce radente. Profilo in alluminio estruso verniciato bianco opaco RAL 9016 (nero semi opaco RAL 9005 a richiesta).

Testate in metacrilato stampato e verniciato bianco.

Gli apparecchi sono completi di circuito LED, converter interno, elementi di giunzione e particolari adesivi per mascherare sbaffi di luce indesiderati.

Da ordinare separatamente: il diffusore in policarbonato satinato, la copertura opaca e le testate di chiusura.

Gli elementi lineari sono disponibili in varie lunghezze da 60 fino a 300 cm con modularità ogni 10 cm (vedi tabella).

Il sistema consente di realizzare grandi configurazioni partendo da un unico punto di alimentazione.

LED disponibili in bianco 2700K, 3000K o 4000K.

A richiesta sono fornibili anche altre tonalità di luce o potenze.

Wall modular system for grazing light.

Profile in extruded aluminum, matt white finish RAL 9016 (semi-matt black RAL 9005 upon request). End pieces in white painted molded methacrylate.

Fixtures are complete of converter, joints, and special patches to mask any unwanted light scatter.

To be ordered separately: satin polycarbonate diffuser, opaque cover end pieces.

Linear elements are available in different lengths from 60 to 300 cm with a 10 cm modularity (see table).

The system allows the realization of wide compositions starting from a single power outlet.

LEDs are available in white 2700K, 3000K, 4000K.

Other light tones and powers can be supplied on request.

Système modulaire a mur pour lumière rasante. Profil en aluminium extrudé verni blanc mat RAL 9016 (noir demi mat RAL 9005 sur requête). Terminales en méthacrylate moulé verni blanc.

Les appareils sont complets de circuit LED, convertisseurs intégré, joints et adhésives spécifiques pour masquer des éventuelles fuites de lumière.

À commander séparément: diffuseur en polycarbonate satiné, couverture opaque et terminales.

Les éléments linéaires sont disponibles dans différentes longueurs de 60 à 300cm avec modularité 10cm (voir table).

Le système permet de créer des grandes configurations à partir d'un seul point d'alimentation.

Trois tonalités de lumière disponibles: 2700, 3000 ou 4000K.

D'autres tonalités de lumière et puissances sont disponibles à la demande.



Modular Wandleuchten-System für Streiflicht. Profil aus stranggepresstem Aluminium matt weiß lackiert RAL 9016 (auf Anfrage halbmatt schwarz RAL 9005).

Endteile aus weiß lackiertem Methacrylat

Die Beleuchtungskörper sind komplett mit LED Platten, 'on board' Konverter, Verbindungsteile und besondere Aufklebern, der eventuelle unerwünschte Lichtflecken entfernen.

Separat zu bestellen: Diffusor aus satiniertem Methacrylat, undurchsichtige Abdeckung und Endteile.

Die einzelnen Lichtsegmente sind in verschiedene Länge von 60 bis 300cm vorgestellt; Modularität je 10 cm (siehe Tabelle).

Von einer einzelnen Stromversorgung Punkt kann man Größe Konfigurationen zusammenfügen.

Drei Lichttonen verfügbar: 2700, 3000 oder 4000K.

Auf Anfrage sind andere Lichttonen oder Leistungen verwendbar.

Sistema modular a pared para luz rasante. Perfil de aluminio extruido pintado blanco mate RAL 9016 (a pedido se hace en Negro semimate RAL 9005).

Finales de metacrilato moldeado pintado blanco.

Los aparatos incluyen placas de LED, convertidor integrado, enganches y autoadhesivos para eliminar manchas de luz no deseadas.

A pedir por separado: difusor de metacrilato satinado, cobertura opaca y terminales.

Los elementos lineares se proponen en diferentes longitudes desde 60 hasta 300 cm, modularidad cada 10 cm (ver tabla).

El sistema permite de crear configuraciones muy grandes a partir de un único punto de alimentación

Tres temperaturas de luz disponibles: 2700, 3000 y 4000K.

A pedido se realizan aparatos con otras temperaturas de luz y potencia.

Настенная модульная система заливающего света. Профиль из экструдированного алюминия или окрашенный в матовый белый цвет RAL 9016 или полуматовый черный RAL 9005 (изготавливается по запросу).

Формованные заглушки из матового метакрилата окрашены в белый цвет. Блок питания внутри профиля, переходники, регулируемые стальные тросы и специальные экраны для избавления от нежелательного рассеянного света.

Отдельно заказываются: рассеиватели из сатинированного поликарбоната и заглушки.

Линейные элементы доступны в различных длинах от 60 до 300 см с шагом 10 см (см. таблицу длин). Соединители: угловые 90°, T и X – образные. Можно создавать широкий набор композиций, запитанных из одной точки. Цветовая температура светодиодного модуля: 2700K, 3000K или 4000K. Светильники с другой цветовой температурой могут быть изготовлены по запросу.

Линейные элементы доступны в различных длинах от 60 до 300 см с шагом 10 см (см. таблицу длин). Соединители: угловые 90°, T и X – образные. Можно создавать широкий набор композиций, запитанных из одной точки. Цветовая температура светодиодного модуля: 2700K, 3000K или 4000K. Светильники с другой цветовой температурой могут быть изготовлены по запросу.

Линейные элементы доступны в различных длинах от 60 до 300 см с шагом 10 см (см. таблицу длин). Соединители: угловые 90°, T и X – образные. Можно создавать широкий набор композиций, запитанных из одной точки. Цветовая температура светодиодного модуля: 2700K, 3000K или 4000K. Светильники с другой цветовой температурой могут быть изготовлены по запросу.

Линейные элементы доступны в различных длинах от 60 до 300 см с шагом 10 см (см. таблицу длин). Соединители: угловые 90°, T и X – образные. Можно создавать широкий набор композиций, запитанных из одной точки. Цветовая температура светодиодного модуля: 2700K, 3000K или 4000K. Светильники с другой цветовой температурой могут быть изготовлены по запросу.

Линейные элементы доступны в различных длинах от 60 до 300 см с шагом 10 см (см. таблицу длин). Соединители: угловые 90°, T и X – образные. Можно создавать широкий набор композиций, запитанных из одной точки. Цветовая температура светодиодного модуля: 2700K, 3000K или 4000K. Светильники с другой цветовой температурой могут быть изготовлены по запросу.

RAIL SYSTEM WALL (luce radente/grazing light)

design: U.T. EGOLUCE

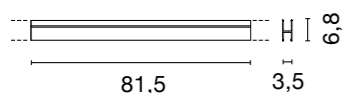

4580 1,1 kg

/xw Led 12W 1424lm 2700K

/ww Led 12W 1520lm 3000K

/w Led 12W 1600lm 4000K



.01/XW .01/WW .01/W

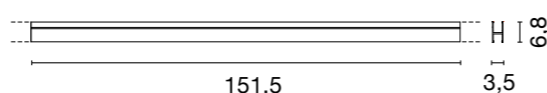

4581 1,5 kg

/xw Led 22,5W 2670lm 2700K

/ww Led 22,5W 2850lm 3000K

/w Led 22,5W 3000lm 4000K



.01/XW .01/WW .01/W

CUSTOM SIZE - Tabella lunghezze disponibili a richiesta. Table of available lengths on request.

cm.	watt	2700K (XW)	lm	3000K (WW)	lm	4000K (W)	lm
61,5	9W	A4580.01/60/XW	1068	A4580.01/60/WW	1140	A4580.01/60/W	1200
71,5	10,5W	A4580.01/70/XW	1246	A4580.01/70/WW	1330	A4580.01/70/W	1400
★ 81,5	12W	4580.01/XW	1424	4580.01/WW	1520	4580.01/W	1600
91,5	13,5W	A4580.01/90/XW	1602	A4580.01/90/WW	1710	A4580.01/90/W	1800
101,5	15W	A4580.01/100/XW	1780	A4580.01/100/WW	1900	A4580.01/100/W	2000
111,5	16,5W	A4580.01/110/XW	1958	A4580.01/110/WW	2090	A4580.01/110/W	2200
121,5	18W	A4580.01/120/XW	2136	A4580.01/120/WW	2280	A4580.01/120/W	2400
131,5	19,5W	A4580.01/130/XW	2314	A4580.01/130/WW	2470	A4580.01/130/W	2600
141,5	21W	A4580.01/140/XW	2492	A4580.01/140/WW	2660	A4580.01/140/W	2800
★ 151,5	22,5W	4581.01/XW	2670	4581.01/WW	2850	4581.01/W	3000
161,5	24W	A4580.01/160/XW	2848	A4580.01/160/WW	3040	A4580.01/160/W	3200
171,5	25,5W	A4580.01/170/XW	3026	A4580.01/170/WW	3230	A4580.01/170/W	3400
181,5	27W	A4580.01/180/XW	3204	A4580.01/180/WW	3420	A4580.01/180/W	3600
191,5	28,5W	A4580.01/190/XW	3382	A4580.01/190/WW	3618	A4580.01/190/W	3800
201,5	30W	A4580.01/200/XW	3560	A4580.01/200/WW	3800	A4580.01/200/W	4000
211,5	31,5W	A4580.01/210/XW	3738	A4580.01/210/WW	3990	A4580.01/210/W	4200
221,5	33W	A4580.01/220/XW	3916	A4580.01/220/WW	4180	A4580.01/220/W	4400
231,5	34,5W	A4580.01/230/XW	4094	A4580.01/230/WW	4370	A4580.01/230/W	4600
241,5	36W	A4580.01/240/XW	4272	A4580.01/240/WW	4560	A4580.01/240/W	4800
251,5	37,5W	A4580.01/250/XW	4450	A4580.01/250/WW	4750	A4580.01/250/W	5000
261,5	39W	A4580.01/260/XW	4628	A4580.01/260/WW	4940	A4580.01/260/W	5200
271,5	40,5W	A4580.01/270/XW	4806	A4580.01/270/WW	5130	A4580.01/270/W	5400
281,5	42W	A4580.01/280/XW	4984	A4580.01/280/WW	5320	A4580.01/280/W	5600
291,5	43,5W	A4580.01/290/XW	5162	A4580.01/290/WW	5510	A4580.01/290/W	5800
301,5	45W	A4580.01/300/XW	5340	A4580.01/300/WW	5700	A4580.01/300/W	6000

★ Articolo standard a catalogo - Standard catalogue item

Accessories



Raccordo parete - plafone
Wall - ceiling joint

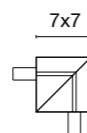

0944 0,15 kg

.01



2 testate di chiusura.
2 closing heads.

0945

.01



Diffusore - Diffuser

0948/200

L. 200cm

0948/300

L. 300cm



Copertura - Polycarbonate screen

0949/200

L. 200cm

0949/300

L. 300cm



RAIL SYSTEM WALL (luce radente/grazing light)

design: U.T. EGOLUCE

Architettura

Architettura



0945
2 testate di chiusura.
2 closing heads
.01



RAIL SYSTEM WALL (luce radente/grazing light)

design: U.T. EGOLUCE

Architettura



Architettura

RAIL SYSTEM RECESSED

design: U.T. EGOLUCE

Architectural

Architectural

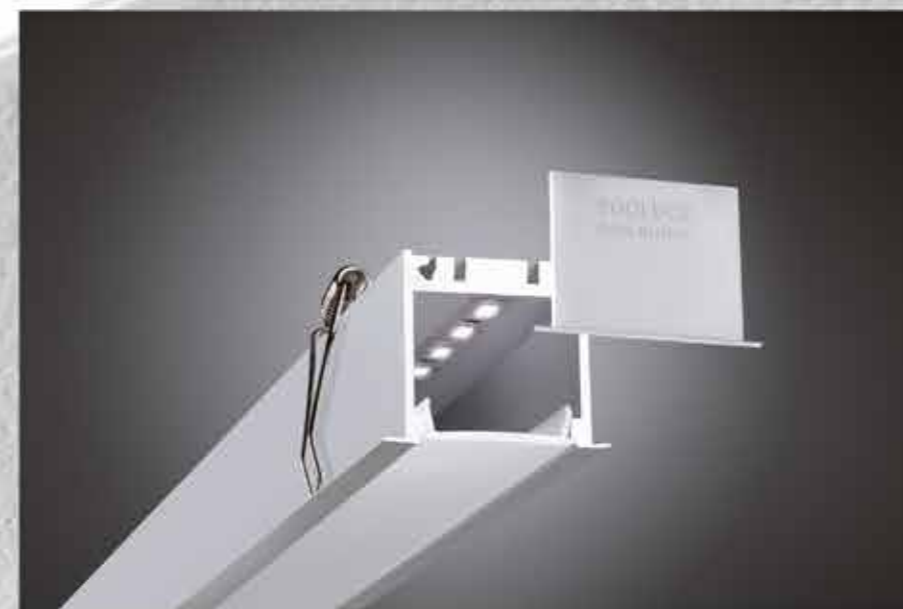

Sistema modulare a luce diffusa ad incasso per pareti e soffitti in cartongesso. Profilo in alluminio estruso verniciato bianco opaco RAL 9016 (nero semiopaco RAL 9005 a richiesta).

Da ordinare separatamente: il diffusore in policarbonato satinato, le testate di chiusura ed il o i converters.

Il sistema si compone di elementi lineari con lunghezze variabili da 60 fino a 300 cm con modularità ogni 10 cm (vedi tabella) a cui si aggiungono giunzioni angolari, a T o a croce. Semplicità e facilità d'installazione sono le caratteristiche che contraddistinguono il sistema.

Il piccolo bordo consente un'installazione che non richiede costose operazioni di stuccatura, rasatura e gessatura.

LED disponibili in bianco 2700K, 3000K o 4000K.

A richiesta sono fornibili anche altre tonalità di luce, potenze o versioni dimmerabili PUSH, 1...10V e DALI.

Recessed modular system for diffused light, for plasterboard false ceilings and walls. Profile in extruded aluminum, matt white finish RAL 9016 (semi-matt black RAL 9005 on request). End pieces in white painted molded methacrylate.

To be ordered separately: satin polycarbonate diffuser, end pieces and converters.

Linear elements are available in different lengths from 60 to 300cm with a 10cm modularity (see table). Joints: 90° Angle, T shaped and cross shaped.

Simplicity and easiness of installation are among the strong points of this system, the reduced mini-trim allows to skip difficult and costly plastering operations.

LEDs are available in white 2700K, 3000K, 4000K.

Other light tones, powers or dimmable versions PUSH, 1...10V and DALI can be supplied on request.

Système modulaire encastrable pour lumière diffuse pour installation dans faux plafonds et murs en plaque-plâtre. Profil en aluminium extrudé verni blanc mat RAL 9016 (noir demi mat RAL 9005 sur requête). Terminales en méthacrylate moulé verni blanc.

À commander séparément: diffuseur en polycarbonate satiné, terminales et convertisseurs.

Les éléments linéaires sont disponibles dans différentes longueurs de 60 à 300cm avec modularité 10 cm (voir table). Joints disponibles: Angle 90°, en forme de T et croix.

Simplicité et facilité d'installation sont les caractéristiques du système. La petite bordure permet d'éviter les frais de plâtrerie et rasage.

Trois tonalités de lumière disponibles: 2700, 3000 ou 4000K.

D'autres tonalités de lumière, différentes puissances ainsi que versions dimmables PUSH, 1...10V et DALI sont disponibles sur requête.

Modular Einbauleuchten-System für diffuses Licht zur Installation in Zwischendecken oder Gipskarton Wände. Profil aus stranggepresstem Aluminium matt weiß lackiert RAL 9016 (auf Anfrage halbmatt schwarz RAL9005). Endteile aus weiß lackiertem Methacrylat

Separat zu bestellen: Diffusor aus satiniertem Methacrylat, Endteile und Konverters.

Die einzelnen Lichtsegmente sind in verschiedene Länge von 60 bis 300cm vorge stellt; Modularität je 10 cm (siehe Tabelle). Zubehör: Ecke 90°, T-förmige Verbinder, Kreuz-verbinder.

Leichtigkeit und einfache Installation sind die Stärken der System. Der kleine Rahmen ermöglicht eine leichte und billige Installation ohne Gipsfertigung.

Drei Lichttonen verfügbar: 2700, 3000 oder 4000K.

Auf Anfrage sind andere Lichttonen, Leistungen und Dimmer PUSH, 1...10V, DALI verwendbar

Sistema modular empotrable para luz difusa. Perfil de aluminio extruido pintado blanco mate RAL 9016 (a pedido se hace en Negro semimate RAL 9005).

Finales de metacrilato moldeado pintado blanco.

A pedir por separado: difusor de metacrilato satinado, terminales y convertidores.

Los elementos lineares se proponen en diferentes longitudes desde 60 hasta 300 cm, modularidad cada 10 cm (ver tabla). Accesorios: esquina 90°, conector a T, conector a cruz.

Simplicidad y facilidad de instalación son los puntos de fuerza de este sistema. el pequeño marco permite una instalación simplificada y ahorra toda las operaciones de acabado del yeso.

Tres temperaturas de luz disponibles: 2700, 3000 y 4000K.

A pedido se relizan aparatos con otras temperaturas de luz, potencia y versiones dimmer PUSH, 1...10V y DALI.

Встраиваемая модульная система заливающего света для гипсокартонных потолков и стен. Профиль из экструдированного алюминия или окрашенный в матовый белый цвет RAL 9016 или полуматовый черный RAL 9005 (изготавливается по запросу). Формованные заглушки из матового метакрилата окрашены в белый цвет.

Отдельно заказываются: рассеиватели из сатинированного поликарбоната, заглушки и блок питания (должен быть выбран исходя из мощности системы).

Линейные элементы доступны в различных длинах от 60 до 300 см с шагом 10 см (см. таблицу длин). Соединители: угловые 90°, T и X – образные.

Достоинствами системы являются простота и легкость установки, также, как и сверхтонкая рамка, которая позволяет избежать трудностей, связанных со штукатурными работами в процессе установки.

Цветовая температура светодиодного модуля: 2700K, 3000K или 4000K.

Другие варианты цветовых температур, мощности, а также версии диммируемые по протоколу DALI доступны по запросу.

RAIL SYSTEM RECESSED

design: U.T. EGOLUCE

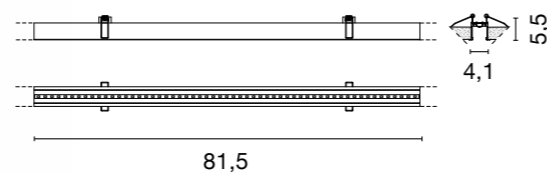

6660 1,1 kg

- /XW Led 12W 1424lm 2700K
- /WW Led 12W 1520lm 3000K
- /W Led 12W 1600lm 4000K



CUSTOM SIZE - Tabella lunghezze disponibili a richiesta. Table of available lengths on request.

cm.	watt	2700K (XW)	lm	3000K (WW)	lm	4000K (W)	lm
11,5	1,5W	A6660.01/10/XW	178	A6660.01/10/WW	190	A6660.01/10/W	200
21,5	3W	A6660.01/20/XW	356	A6660.01/20/WW	380	A6660.01/20/W	400
31,5	4,5W	A6660.01/30/XW	534	A6660.01/30/WW	570	A6660.01/30/W	600
41,5	6W	A6660.01/40/XW	712	A6660.01/40/WW	760	A6660.01/40/W	800
51,5	7,5W	A6660.01/50/XW	890	A6660.01/50/WW	950	A6660.01/50/W	1000
61,5	9W	A6660.01/60/XW	1068	A6660.01/60/WW	1140	A6660.01/60/W	1200
71,5	10,5W	A6660.01/70/XW	1246	A6660.01/70/WW	1330	A6660.01/70/W	1400
* 81,5	12W	6660.01/XW	1424	6660.01/WW	1520	6660.01/W	1600
91,5	13,5W	A6660.01/90/XW	1602	A6660.01/90/WW	1710	A6660.01/90/W	1800
101,5	15W	A6660.01/100/XW	1780	A6660.01/100/WW	1900	A6660.01/100/W	2000
111,5	16,5W	A6660.01/110/XW	1958	A6660.01/110/WW	2090	A6660.01/110/W	2200
121,5	18W	A6660.01/120/XW	2136	A6660.01/120/WW	2280	A6660.01/120/W	2400
131,5	19,5W	A6660.01/130/XW	2314	A6660.01/130/WW	2470	A6660.01/130/W	2600
141,5	21W	A6660.01/140/XW	2492	A6660.01/140/WW	2660	A6660.01/140/W	2800
151,5	22,5W	A6660.01/150/XW	2670	A6660.01/150/WW	2850	A6660.01/150/W	3000
161,5	24W	A6660.01/160/XW	2848	A6660.01/160/WW	3040	A6660.01/160/W	3200
171,5	25,5W	A6660.01/170/XW	3026	A6660.01/170/WW	3230	A6660.01/170/W	3400
181,5	27W	A6660.01/180/XW	3204	A6660.01/180/WW	3420	A6660.01/180/W	3600
191,5	28,5W	A6660.01/190/XW	3382	A6660.01/190/WW	3618	A6660.01/190/W	3800
201,5	30W	A6660.01/200/XW	3560	A6660.01/200/WW	3800	A6660.01/200/W	4000
211,5	31,5W	A6660.01/210/XW	3738	A6660.01/210/WW	3990	A6660.01/210/W	4200
221,5	33W	A6660.01/220/XW	3916	A6660.01/220/WW	4180	A6660.01/220/W	4400
231,5	34,5W	A6660.01/230/XW	4094	A6660.01/230/WW	4370	A6660.01/230/W	4600
241,5	36W	A6660.01/240/XW	4272	A6660.01/240/WW	4560	A6660.01/240/W	4800
251,5	37,5W	A6660.01/250/XW	4450	A6660.01/250/WW	4750	A6660.01/250/W	5000
261,5	39W	A6660.01/260/XW	4628	A6660.01/260/WW	4940	A6660.01/260/W	5200
271,5	40,5W	A6660.01/270/XW	4806	A6660.01/270/WW	5130	A6660.01/270/W	5400
281,5	42W	A6660.01/280/XW	4984	A6660.01/280/WW	5320	A6660.01/280/W	5600
291,5	43,5W	A6660.01/290/XW	5162	A6660.01/290/WW	5510	A6660.01/290/W	5800
301,5	45W	A6660.01/300/XW	5340	A6660.01/300/WW	5700	A6660.01/300/W	6000

* Articolo standard a catalogo - Standard catalogue item

FORO INCASSO - CUTOUT

La lunghezza totale del foro d'incasso si ottiene aggiungendo 0,6 cm alla somma delle lunghezze dei singoli pezzi (vedi schema pag 49).
Total length of the cutout is obtained by adding 0,6 cm to the sum of each component length. (pg. 49)

Accessories



Giunzione a croce - Cross joint

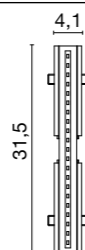

0956 0,35 kg

- /XW Led 4,5W 534lm 2700K
- /WW Led 4,5W 570lm 3000K
- /W Led 4,5W 600lm 4000K



Angolo 90° - 90° Corner

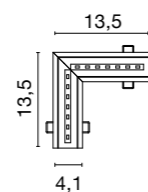

0957 0,4 kg

- /XW Led 3W 356lm 2700K
- /WW Led 3W 380lm 3000K
- /W Led 3W 400lm 4000K



Giunzione a T - T joint

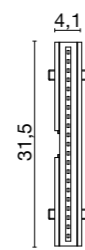

0958 0,35kg

- /XW Led 4,5W 534lm 2700K
- /WW Led 4,5W 570lm 3000K
- /W Led 4,5W 600lm 4000K



Diffusore - Diffuser

0948/200

L. 200cm

0948/300

L. 300cm

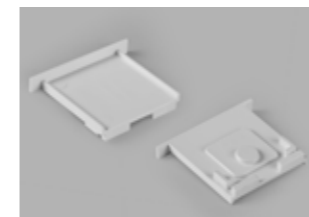

2 testate di chiusura.
2 closing heads.

0939

.01

Drivers



0156 24V 25W

0160 24V 50W

0157 24V 72W

0162 24V 150W

0161/100
24V 100W

0110/DIM
Dimmer 24V

0117/DIM60
Dimmer - 60W

0117/DIM100
Dimmer - 100W

0115/EM
Emergency Unit

RAIL SYSTEM RECESSED

design: U.T. EGOLUCE

Architettura

Architettura

0939
2 testate di chiusura.
2 closing heads
.01

0956
Giunzione a croce - Cross joint
.01/XW .01/WW .01/W

0957
Angolo 90° - 90° Corner
.01/XW .01/WW .01/W

0958
Giunzione a T - T joint
.01/XW .01/WW .01/W

0948/200
Diffusore - Diffuser
L. 200cm

0948/300
Diffusore - Diffuser
L. 300cm

24V DC

0956



0957

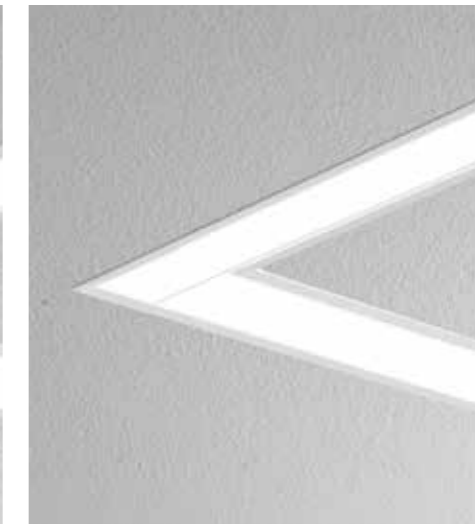

0958

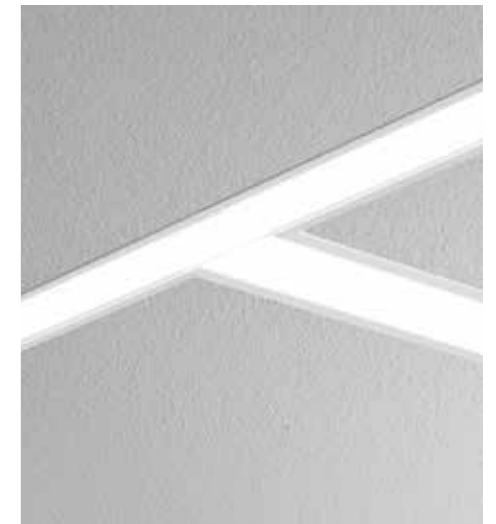

RAIL SYSTEM RECESSED

design: U.T. EGOLUCE

Architettura



Architettura

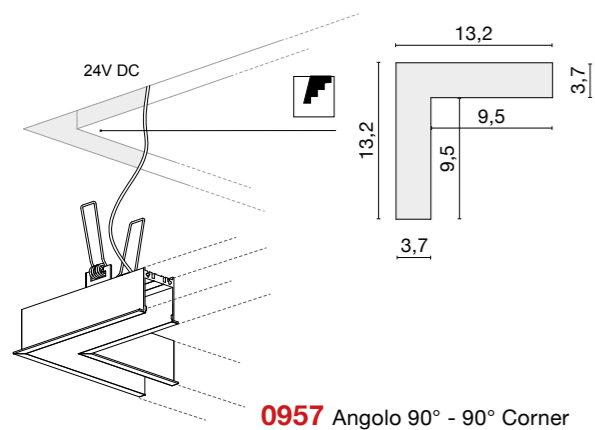

Lunghezze superiori ai 3 metri si ottengono accostando i singoli elementi, il foro d'incasso si calcola con la seguente formula:
 Configurations longer than 3 meters can be obtained by putting single fittings side by side in a row, the cutout length can be calculated with the formula hereunder:

Esempi - Examples $3,7 \times L$ cm.

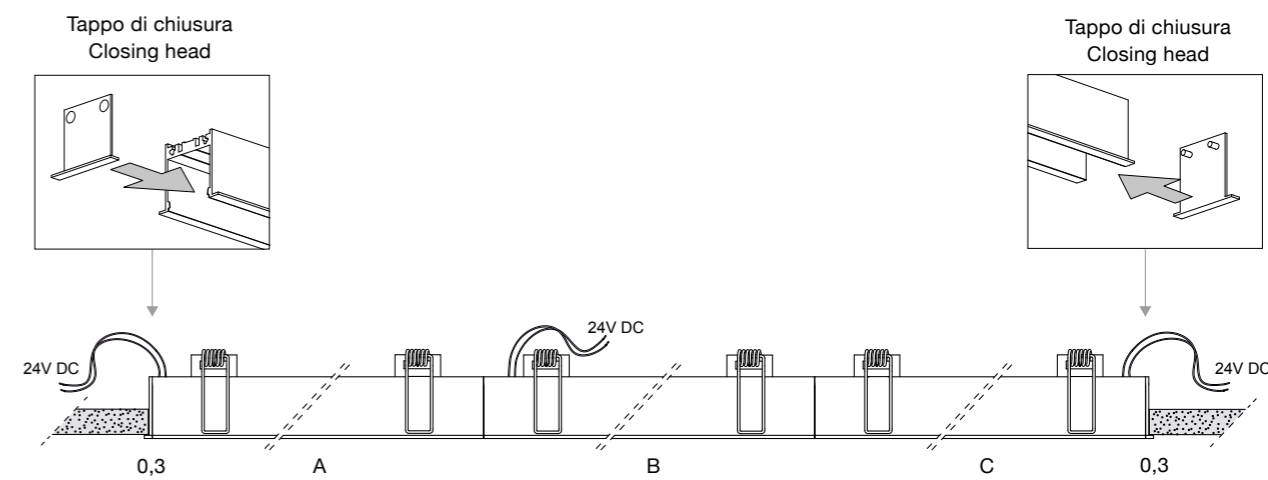

$$L = 0,3 + A + B + C + 0,3$$

A B C = Lunghezza delle lampade senza tappi di chiusura. Lamps length without closing heads.



Lampada a sospensione singola per luce diffusa. Profilo in alluminio estruso verniciato bianco opaco RAL 9016 (nero semiopaco RAL 9005 a richiesta). Testate in metacrilato stampato verniciato bianco, il diffusore è in policarbonato satinato.

Sono disponibili varie misure da 60 fino a 300 cm con modularità ogni 10 cm (vedi tabella). LED disponibili in bianco 2700K, 3000K o 4000K.

A richiesta sono fornite altre tonalità di luce potenze e versioni dimmerabili PUSH, 1...10V e DALI.

Pendelleuchte für diffuses Licht. Profil aus stranggepresstem Aluminium matt weiß lackiert RAL 9016 (auf Anfrage halbmatt schwarz RAL 9005). Endteile aus weiß lackiertem Methacrylat

Die Leuchten sind in verschiedene Länge von 60 bis 300cm vorgestellt; Modularität je 10 cm (siehe Tabelle).

Drei Lichttonen verfügbar: 2700, 3000 oder 4000K.

Auf Anfrage sind andere Lichttonen, Leistungen und Dimmer PUSH, 1...10V, DALI verwendbar

Single suspension lamp for diffused light. Profile in extruded aluminum, matt white finish RAL 9016 (semi-matt black RAL 9005 upon request). End pieces in white painted molded methacrylate.

Elements are available in different lengths from 60 to 300 cm with a 10 cm modularity (see table).

LEDs are available in white 2700K, 3000K, 4000K.

Other light tones, powers or dimmable versions PUSH, 1...10V and DALI can be supplied upon request.

Colgante para luz difusa. Perfil de aluminio extruido pintado blanco mate RAL 9016 (a pedido se hace en Negro semimate RAL 9005).

Finales de metacrilato moldeado pintado blanco.

Los elementos lineares se proponen en diferentes longitudes desde 60 hasta 300 cm, modularidad cada 10 cm (ver tabla).

Tres temperaturas de luz disponibles: 2700, 3000 y 4000K.

A pedido se relizan aparatos con otras temperaturas de luz, potencia y versiones dimmer PUSH, 1...10V y DALI.

Suspension pour lumière diffuse Profile en aluminium extrudé verni blanc mat RAL 9016 (noir demi mat RAL 9005 sur requête). Terminales en méthacrylate moulé verni blanc. Les éléments linéaires sont disponibles dans différentes longueurs de 60 à 300cm avec modularité 10cm (voir table).

Trois tonalités de lumière disponibles: 2700, 3000 ou 4000K.

D'autres tonalités de lumière, différentes puissances ainsi que versions dimmables PUSH, 1...10V et DALI sont disponibles sur requête.

Отдельные светильники для равномерного диффузного освещения. Профиль из экструдированного алюминия или окрашенный в матовый белый цвет RAL 9016 или полуматовый черный RAL 9005 (изготавливается по запросу).

Формованные заглушки из матового метакрилата окрашены в белый цвет. Линейные элементы доступны в различных длинах от 60 до 300 см с шагом 10 см (см. таблицу длин).

Цветовая температура светодиодного модуля: 2700K, 3000K или 4000K. По запросу доступна опция диммирования PUSH, 1...10V, DALI, а также другие варианты цветовых температур и мощности.

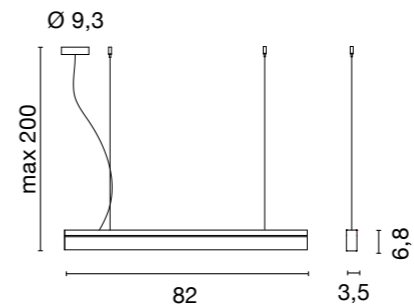

1541 1,1 kg

/xw Led 12W 1424lm 2700K

/ww Led 12W 1520lm 3000K

/w Led 12W 1600lm 4000K



.01/XW .01/WW .01/W

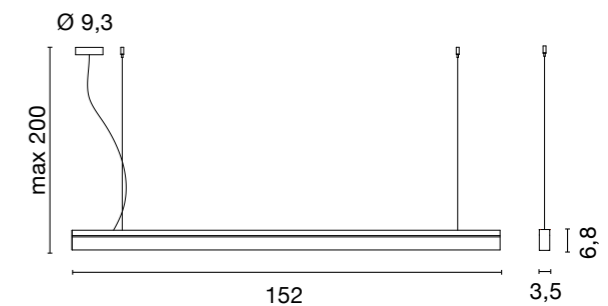

1542 1,5 kg

/xw Led 22,5W 2670lm 2700K

/ww Led 22,5W 2850lm 3000K

/w Led 22,5W 3000lm 4000K



.01/XW .01/WW .01/W

CUSTOM SIZE - Tabella lunghezze disponibili a richiesta. Table of available lengths on request.

cm.	watt	2700K (XW)	lm	3000K (WW)	lm	4000K (W)	lm
62	9W	A1541.01/60/XW	1068	A1541.01/60/WW	1140	A1541.01/60/W	1200
72	10,5W	A1541.01/70/XW	1246	A1541.01/70/WW	1330	A1541.01/70/W	1400
★ 82	12W	1541.01/XW	1424	1541.01/WW	1520	1541.01/W	1600
92	13,5W	A1541.01/90/XW	1602	A1541.01/90/WW	1710	A1541.01/90/W	1800
102	15W	A1541.01/100/XW	1780	A1541.01/100/WW	1900	A1541.01/100/W	2000
112	16,5W	A1541.01/110/XW	1958	A1541.01/110/WW	2090	A1541.01/110/W	2200
122	18W	A1541.01/120/XW	2136	A1541.01/120/WW	2280	A1541.01/120/W	2400
132	19,5W	A1541.01/130/XW	2314	A1541.01/130/WW	2470	A1541.01/130/W	2600
142	21W	A1541.01/140/XW	2492	A1541.01/140/WW	2660	A1541.01/140/W	2800
★ 152	22,5W	1542.01/XW	2670	1542.01/WW	2850	1542.01/W	3000
162	24W	A1541.01/160/XW	2848	A1541.01/160/WW	3040	A1541.01/160/W	3200
172	25,5W	A1541.01/170/XW	3026	A1541.01/170/WW	3230	A1541.01/170/W	3400
182	27W	A1541.01/180/XW	3204	A1541.01/180/WW	3420	A1541.01/180/W	3600
192	28,5W	A1541.01/190/XW	3382	A1541.01/190/WW	3618	A1541.01/190/W	3800
202	30W	A1541.01/200/XW	3560	A1541.01/200/WW	3800	A1541.01/200/W	4000
212	31,5W	A1541.01/210/XW	3738	A1541.01/210/WW	3990	A1541.01/210/W	4200
222	33W	A1541.01/220/XW	3916	A1541.01/220/WW	4180	A1541.01/220/W	4400
232	34,5W	A1541.01/230/XW	4094	A1541.01/230/WW	4370	A1541.01/230/W	4600
242	36W	A1541.01/240/XW	4272	A1541.01/240/WW	4560	A1541.01/240/W	4800
252	37,5W	A1541.01/250/XW	4450	A1541.01/250/WW	4750	A1541.01/250/W	5000
262	39W	A1541.01/260/XW	4628	A1541.01/260/WW	4940	A1541.01/260/W	5200
272	40,5W	A1541.01/270/XW	4806	A1541.01/270/WW	5130	A1541.01/270/W	5400
282	42W	A1541.01/280/XW	4984	A1541.01/280/WW	5320	A1541.01/280/W	5600
292	43,5W	A1541.01/290/XW	5162	A1541.01/290/WW	5510	A1541.01/290/W	5800
302	45W	A1541.01/300/XW	5340	A1541.01/300/WW	5700	A1541.01/300/W	6000

★ Articolo standard a catalogo - Standard catalogue item

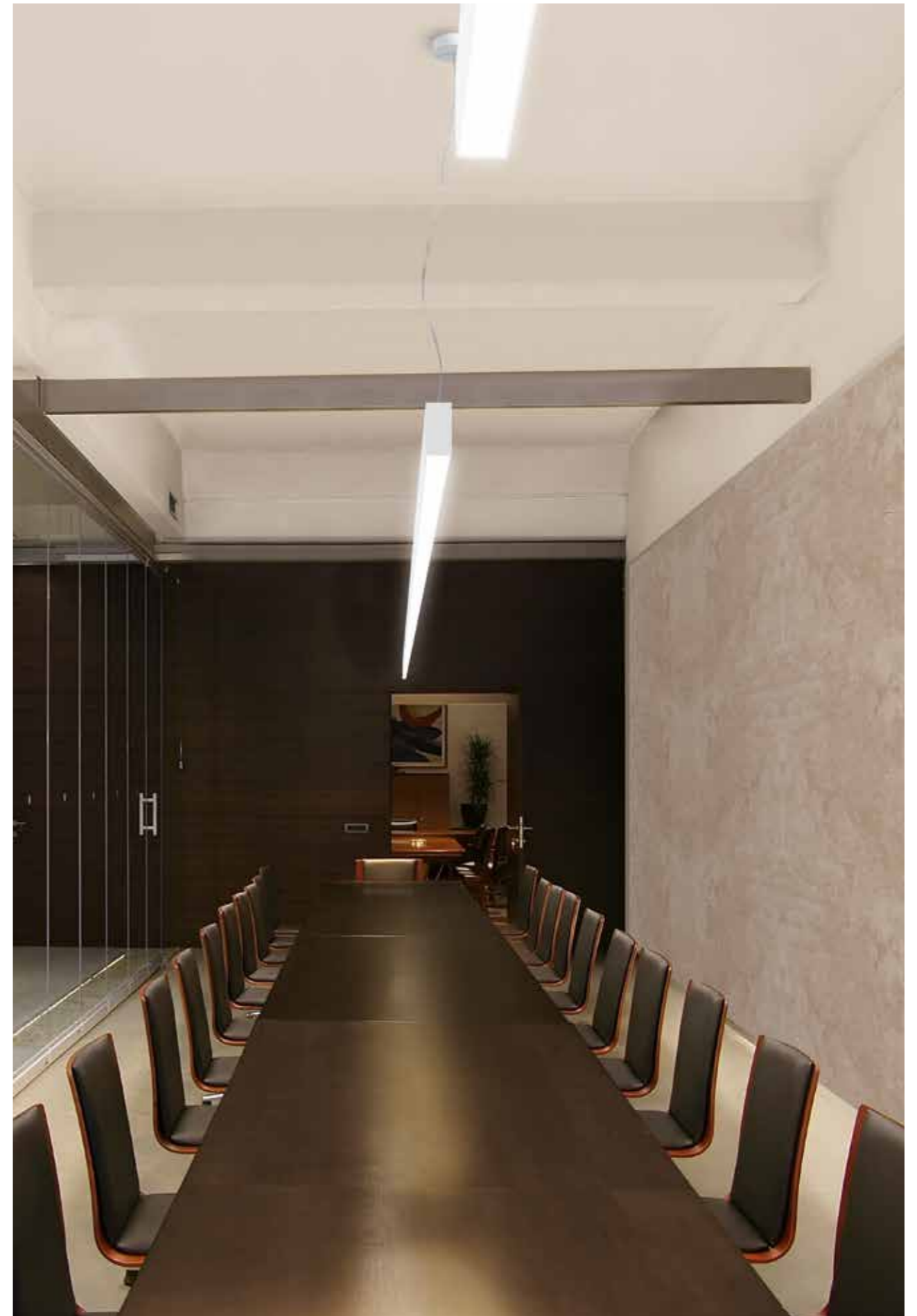

RAIL SUSPENSION DOUBLE EMISSION

design: U.T. EGOLUCE

Architectural



Lampada a sospensione singola a luce diffusa diretta ed indiretta. Corpo in alluminio estruso verniciato bianco RAL 9016 opaco (nero semiopaco RAL 9005 a richiesta). Testate in metacrilato stampato, diffusore in policarbonato satinato. Disponibile in varie misure da 120 fino a 300 cm con modularità di taglio ogni 20 cm (vedi tabella). LED disponibili in bianco 2700K, 3000K o 4000K.

A richiesta sono fornite altre tonalità di luce potenze e versioni doppia accensione.

Pendelleuchte für direktes und indirektes Licht. Profil aus stranggepresstem Aluminium matt weiß lackiert RAL 9016 (auf Anfrage halbmatte schwarz RAL 9005).

Endteile aus weiß lackiertem Methacrylat Die Leuchten sind in verschiedene Länge von 60 bis 300cm vorgestellt; Modularität je 10 cm (siehe Tabelle).

Drei Lichttöne verfügbar: 2700, 3000 oder 4000K.

Auf Anfrage sind andere Lichttöne und Doppelschaltung verwendbar.

Single Suspension lamp for direct and indirect diffused light. Profile in extruded aluminum, matt white finish RAL 9016 (semi-matt black RAL 9005 on request). End pieces in white painted molded methacrylate.

Elements are available in different lengths from 120 to 300cm with a 20 cm modularity (see table). LEDs are available in white 2700K, 3000K, 4000K.

Other light tones, powers or double switch versions can be supplied upon request.

Colgante para luz difusa directa y indirecta. Perfil de aluminio extruido pintado blanco mate RAL 9016 (a pedido se hace en Negro semimatte RAL 9005).

Finales de metacrilato moldeado pintado blanco.

Los elementos lineares se proponen en diferentes longitudes desde 60 hasta 300cm, modularidad cada 10cm (ver tabla).

Tres temperaturas de luz disponibles: 2700, 3000 y 4000K.

A pedido se relizan aparatos con otras temperaturas de luz y versiones con doble encendido.

Suspension pour lumière directe et indirecte. Profil en aluminium extrudé verni blanc mat RAL 9016 (noir demi mat RAL 9005 sur requête). Terminales en méthacrylate moulé verni blanc.

Les éléments linéaires sont disponibles dans différentes longueurs de 120 à 300 cm avec modularité 20cm (voir table).

Trois tonalités de lumière disponibles: 2700, 3000 ou 4000K.

D'autres tonalités de lumière ou versions double allumage sont disponibles sur requête.

Подвесные светильники с излучением вверх-вниз для направленного и рассеянного света. Профиль из экструдированного алюминия или окрашенный в матовый белый цвет RAL 9016 или полуматовый черный RAL 9005 (изготавливается по запросу).

Формованные заглушки из матового метакрилата окрашены в белый цвет. Линейные элементы доступны в различных длинах от 120 до 300 см с шагом 20 см (см. таблицу длин).

Цветовая температура светодиодного модуля: 2700K, 3000K или 4000K

По запросу другие варианты цветовых температур и мощности.



Architectural

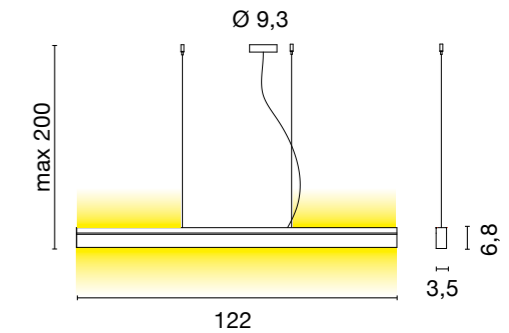

1545 1,3 kg

/XW Led 30W 1424lm up light + 2136lm down light 2700K

/WW Led 30W 1520lm up light + 2280lm down light 3000K

/W Led 30W 1600lm up light + 2400lm down light 4000K



.01/XW .01/WW .01/W

CUSTOM SIZE - Tabella lunghezze disponibili a richiesta. Table of available lengths on request.

cm.	watt	2700K (XW)		3000K (WW)		4000K (W)	
		lm up	lm down	lm up	lm down	lm up	lm down
★ 122	30W	1545.01/XW	1424 2136	1545.01/WW	1520 2280	1545.01/W	1600 2400
142	36W	A1545.01/140/XW	1780 2492	A1545.01/140/WW	1900 2660	A1545.01/140/W	2000 2800
162	42W	A1545.01/160/XW	2136 2848	A1545.01/160/WW	2280 3040	A1545.01/160/W	2400 3200
182	48W	A1545.01/180/XW	2492 3204	A1545.01/180/WW	2660 3420	A1545.01/180/W	2800 3600
202	54W	A1545.01/200/XW	2848 3650	A1545.01/200/WW	3040 3800	A1545.01/200/W	3200 4000
222	54W	A1545.01/220/XW	2492 3916	A1545.01/220/WW	2660 4180	A1545.01/220/W	2800 4400
242	60W	A1545.01/240/XW	2848 4272	A1545.01/240/WW	3040 4560	A1545.01/240/W	3200 4800
262	66W	A1545.01/260/XW	3204 4628	A1545.01/260/WW	3420 4940	A1545.01/260/W	3600 5200
282	72W	A1545.01/280/XW	3560 4984	A1545.01/280/WW	3800 5320	A1545.01/280/W	4000 5600
302	78W	A1545.01/300/XW	3916 5340	A1545.01/300/WW	4180 5700	A1545.01/300/W	4400 6000

★ Articolo standard a catalogo - Standard catalogue item

RAIL WALL (luce radente/grazing light)

design: U.T. EGOLUCE

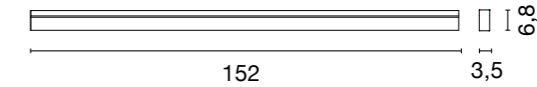
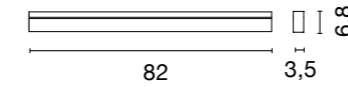

4578 1,1 kg

/xw Led 12W 1424lm 2700K

/ww Led 12W 1520lm 3000K

/w Led 12W 1600lm 4000K



.01/XW .01/WW .01/W

4579 1,5 kg

/xw Led 22,5W 2670lm 2700K

/ww Led 22,5W 2850lm 3000K

/w Led 22,5W 3000lm 4000K



.01/XW .01/WW .01/W

Lampada da parete singola per luce radente. Profilo in alluminio estruso verniciato bianco RAL 9016 opaco (nero semiopaco RAL 9005 a richiesta).

Testate in metacrilato stampato verniciato bianco, diffusore in policarbonato satinato. Disponibili varie misure da 60 fino a 300 cm con modularità ogni 10 cm (vedi tabella).

LED disponibili in bianco 2700K, 3000K o 4000K.

A richiesta sono fornite altre tonalità di luce potenze e versioni dimmerabili PUSH, 1...10V e DALI.

Wandleuchte für Streiflicht. Profil aus stranggepresstem Aluminium matt weiß lackiert RAL 9016 (auf Anfrage halbmatte schwarz RAL 9005). Endteile aus weiß lackiertem Methacrylat

Die Leuchten sind in verschiedene Länge von 60 bis 300 cm vorgestellt; Modularität je 10 cm (siehe Tabelle).

Drei Lichttönen verfügbar: 2700, 3000 oder 4000K.

Auf Anfrage sind andere Lichttöne Leistungen und Dimmer PUSH, 1...10V, DALI verwendbar

Single wall lamp for grazing light. Profile in extruded aluminum, matt white finish RAL 9016 (semi-matt black RAL 9005 upon request). End pieces in white painted molded methacrylate.

Elements are available in different lengths from 60 to 300 cm with a 10 cm modularity (see table).

LEDs are available in white 2700K, 3000K, 4000K.

Other light tones, powers or dimmable version PUSH, 1...10V and DALI can be supplied on request.

Lampara de pared para luz rasante. Perfil de aluminio extruido pintado blanco mate RAL 9016 (a pedido se hace en Negro semimatte RAL 9005).

Finales de metacrilato moldeado pintado blanco.

Los elementos lineares se proponen en diferentes larguras desde 60 hasta 300 cm, modularidad cada 10cm (ver tabla).

Tres temperaturas de luz disponibles: 2700, 3000 y 4000K.

A pedido se relizan aparatos con otras temperaturas de luz, potencia y versiones dimmer PUSH, 1...10V y DALI.

Lampe murale pour lumière rasante. Profil en aluminium extrudé verni blanc mat RAL 9016 (noir demi mat RAL 9005 sur requête). Terminales en méthacrylate moulé verni blanc.

Les éléments linéaires sont disponibles dans différentes longueurs de 60 à 300 cm avec modularité 10 cm (voir table).

Trois tonalités de lumière disponibles: 2700, 3000 ou 4000K.

D'autres tonalités de lumière, différentes puissances ainsi que versions dimmables PUSH, 1...10V et DALI sont disponibles sur requête.

Отдельные светильники заливающего света. Профиль из экструдированного алюминия или окрашенный в матовый белый цвет RAL9016 или полуматовый черный RAL 9005 (изготавливается по запросу). Формованные заглушки из матового метакрилата окрашены в белый цвет.

Линейные элементы доступны в различных длинах от 60 до 300 см с шагом 10 см (см. таблицу длин).

Цветовая температура светодиодного модуля: 2700K, 3000K или 4000K

По запросу доступна опция диммирования PUSH, 1...10V, DALI, а также другие варианты цветовых температур и мощности.

CUSTOM SIZE - Tabella lunghezze disponibili a richiesta. Table of available lengths on request.

cm.	watt	2700K (XW)	lm	3000K (WW)	lm	4000K (W)	lm
62	9W	A4578.01/60/XW	1068	A4578.01/60/WW	1140	A4578.01/60/W	1200
72	10,5W	A4578.01/70/XW	1246	A4578.01/70/WW	1330	A4578.01/70/W	1400
★ 82	12W	4578.01/XW	1424	4578.01/WW	1520	4578.01/W	1600
92	13,5W	A4578.01/90/XW	1602	A4578.01/90/WW	1710	A4578.01/90/W	1800
102	15W	A4578.01/100/XW	1780	A4578.01/100/WW	1900	A4578.01/100/W	2000
112	16,5W	A4578.01/110/XW	1958	A4578.01/110/WW	2090	A4578.01/110/W	2200
122	18W	A4578.01/120/XW	2136	A4578.01/120/WW	2280	A4578.01/120/W	2400
132	19,5W	A4578.01/130/XW	2314	A4578.01/130/WW	2470	A4578.01/130/W	2600
142	21W	A4578.01/140/XW	2492	A4578.01/140/WW	2660	A4578.01/140/W	2800
★ 152	22,5W	4579.01/XW	2670	4579.01/WW	2850	4579.01/W	3000
162	24W	A4578.01/160/XW	2848	A4578.01/160/WW	3040	A4578.01/160/W	3200
172	25,5W	A4578.01/170/XW	3026	A4578.01/170/WW	3230	A4578.01/170/W	3400
182	27W	A4578.01/180/XW	3204	A4578.01/180/WW	3420	A4578.01/180/W	3600
192	28,5W	A4578.01/190/XW	3382	A4578.01/190/WW	3618	A4578.01/190/W	3800
202	30W	A4578.01/200/XW	3560	A4578.01/200/WW	3800	A4578.01/200/W	4000
212	31,5W	A4578.01/210/XW	3738	A4578.01/210/WW	3990	A4578.01/210/W	4200
222	33W	A4578.01/220/XW	3916	A4578.01/220/WW	4180	A4578.01/220/W	4400
232	34,5W	A4578.01/230/XW	4094	A4578.01/230/WW	4370	A4578.01/230/W	4600
242	36W	A4578.01/240/XW	4272	A4578.01/240/WW	4560	A4578.01/240/W	4800
252	37,5W	A4578.01/250/XW	4450	A4578.01/250/WW	4750	A4578.01/250/W	5000
262	39W	A4578.01/260/XW	4628	A4578.01/260/WW	4940	A4578.01/260/W	5200
272	40,5W	A4578.01/270/XW	4806	A4578.01/270/WW	5130	A4578.01/270/W	5400
282	42W	A4578.01/280/XW	4984	A4578.01/280/WW	5320	A4578.01/280/W	5600
292	43,5W	A4578.01/290/XW	5162	A4578.01/290/WW	5510	A4578.01/290/W	5800
302	45W	A4578.01/300/XW	5340	A4578.01/300/WW	5700	A4578.01/300/W	6000

★ Articolo standard a catalogo - Standard catalogue item

RAIL CEILING WALL

design: U.T. EGOLUCE

Architectural



Lampada singola da soffitto/parete a luce diffusa. Profilo in alluminio estruso verniciato bianco opaco RAL 9016 (nero semiopaco RAL 9005 a richiesta). Testate in metacrilato stampato verniciato bianco, diffusore in policarbonato satinato. Disponibili varie misure da 60 fino a 300 cm con modularità ogni 10 cm (vedi tabella). LED disponibili in bianco 2700K, 3000K o 4000K. A richiesta sono fornite altre tonalità di luce potenze e versioni dimmerabili PUSH, 1...10V e DALI.

Wand-/Deckenleuchte für diffuses Licht. Profil aus stranggepresstem Aluminium matt weiß lackiert RAL 9016 (auf Anfrage halb-matt schwarz RAL 9005). Endteile aus weiß lackiertem Methacrylat. Die Leuchten sind in verschiedene Länge von 60 bis 300 cm vorgestellt; Modularität je 10 cm (siehe Tabelle). Drei Lichttonen verfügbar: 2700, 3000 oder 4000K. Auf Anfrage sind andere Lichttonen, Leistungen oder Dimmer PUSH, 1...10V, DALI verwendbar.

Single ceiling/wall lamp for diffused light. Profile in extruded aluminum, matt white finish RAL 9016 (semi-matt black RAL 9005 upon request). End pieces in white painted molded methacrylate. Elements are available in different lengths from 60 to 300 cm with a 10 cm modularity (see table). LEDs are available in white 2700K, 3000K, 4000K. Other light tones, powers or dimmable versions PUSH, 1...10V and DALI can be supplied on request.

Lampara de pared/techo para luz difusa. Perfil de aluminio extruido pintado blanco mate RAL 9016 (a pedido se hace en Negro semimatte RAL 9005). Finales de metacrilato moldeado pintado blanco. Los elementos lineares se proponen en diferentes larguras desde 60 hasta 300 cm, modularidad cada 10cm (ver tabla). Tres temperaturas de luz disponibles: 2700, 3000 y 4000K. A pedido se relizan aparatos con otras temperaturas de luz, potencia y versiones dimmer PUSH, 1...10V y DALI.

Applique / plafonnier pour lumière diffuse. Profile en aluminium extrudé verni blanc mat RAL 9016 (noir demi mat RAL 9005 sur requête). Terminales en méthacrylate moulé verni blanc. Les éléments linéaires sont disponibles dans différentes longueurs de 60 à 300 cm avec modularité 10 cm (voir table). Trois tonalités de lumière disponibles: 2700, 3000 ou 4000K. D'autres tonalités de lumière, différentes puissances ainsi que versions dimmables PUSH, 1...10V et DALI sont disponibles sur requête.

Отдельные светильники для равномерного диффузного освещения. Профиль из экструдированного алюминия или окрашенный в матовый белый цвет RAL 9016 или полуматовый черный RAL 9005 (изготавливается по запросу). Формованные заглушки из матового метакрилата окрашены в белый цвет. Линейные элементы доступны в различных длинах от 60 до 300 см с шагом 10 см (см. таблицу длин). Цветовая температура светодиодного модуля: 2700K, 3000K или 4000K. По запросу доступна опция диммирования PUSH, 1...10V, DALI, а также другие варианты цветовых температур и мощности.



Architectural

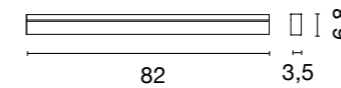

5540 1,1 kg

/xw Led 12W 1424lm 2700K

/ww Led 12W 1520lm 3000K

/w Led 12W 1600lm 4000K



.01/XW .01/WW .01/W

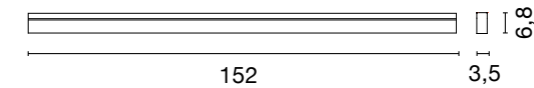

5541 1,5 kg

/xw Led 22,5W 2670lm 2700K

/ww Led 22,5W 2850lm 3000K

/w Led 22,5W 3000lm 4000K



.01/XW .01/WW .01/W

CUSTOM SIZE - Tabella lunghezze disponibili a richiesta. Table of available lengths on request.

cm.	watt	2700K (XW)	lm	3000K (WW)	lm	4000K (W)	lm
62	9W	A5540.01/60/XW	1068	A5540.01/60/WW	1140	A5540.01/60/W	1200
72	10,5W	A5540.01/70/XW	1246	A5540.01/70/WW	1330	A5540.01/70/W	1400
★ 82	12W	5540.01/XW	1424	5540.01/WW	1520	5540.01/W	1600
92	13,5W	A5540.01/90/XW	1602	A5540.01/90/WW	1710	A5540.01/90/W	1800
102	15W	A5540.01/100/XW	1780	A5540.01/100/WW	1900	A5540.01/100/W	2000
112	16,5W	A5540.01/110/XW	1958	A5540.01/110/WW	2090	A5540.01/110/W	2200
122	18W	A5540.01/120/XW	2136	A5540.01/120/WW	2280	A5540.01/120/W	2400
132	19,5W	A5540.01/130/XW	2314	A5540.01/130/WW	2470	A5540.01/130/W	2600
142	21W	A5540.01/140/XW	2492	A5540.01/140/WW	2660	A5540.01/140/W	2800
★ 152	22,5W	5541.01/XW	2670	5541.01/WW	2850	5541.01/W	3000
162	24W	A5540.01/160/XW	2848	A5540.01/160/WW	3040	A5540.01/160/W	3200
172	25,5W	A5540.01/170/XW	3026	A5540.01/170/WW	3230	A5540.01/170/W	3400
182	27W	A5540.01/180/XW	3204	A5540.01/180/WW	3420	A5540.01/180/W	3600
192	28,5W	A5540.01/190/XW	3382	A5540.01/190/WW	3618	A5540.01/190/W	3800
202	30W	A5540.01/200/XW	3560	A5540.01/200/WW	3800	A5540.01/200/W	4000
212	31,5W	A5540.01/210/XW	3738	A5540.01/210/WW	3990	A5540.01/210/W	4200
222	33W	A5540.01/220/XW	3916	A5540.01/220/WW	4180	A5540.01/220/W	4400
232	34,5W	A5540.01/230/XW	4094	A5540.01/230/WW	4370	A5540.01/230/W	4600
242	36W	A5540.01/240/XW	4272	A5540.01/240/WW	4560	A5540.01/240/W	4800
252	37,5W	A5540.01/250/XW	4450	A5540.01/250/WW	4750	A5540.01/250/W	5000
262	39W	A5540.01/260/XW	4628	A5540.01/260/WW	4940	A5540.01/260/W	5200
272	40,5W	A5540.01/270/XW	4806	A5540.01/270/WW	5130	A5540.01/270/W	5400
282	42W	A5540.01/280/XW	4984	A5540.01/280/WW	5320	A5540.01/280/W	5600
292	43,5W	A5540.01/290/XW	5162	A5540.01/290/WW	5510	A5540.01/290/W	5800
302	45W	A5540.01/300/XW	5340	A5540.01/300/WW	5700	A5540.01/300/W	6000

★ Articolo standard a catalogo - Standard catalogue item

ALEA LED

design: U.T. EGOLUCE

Architectural



Lampada a soffitto in alluminio verniciato con sorgente COB LED ed alimentatore integrato. Disponibile nelle finiture: bianco e nero.

Ceiling lamp in painted aluminum fitted with COB LED light engine and converter on board. White and black finish.

Lampe à plafond en aluminium verni avec source de lumière COB LED et alimentation intégré.

Disponibile en finitions: blanc et noire.

Deckenleuchte aus lackiertem Aluminium mit COB LED-Modul. Integrierter Konverter. Erhältlich in folgenden Ausführungen: Weiß und schwarz.

Lámpara de techo en aluminio pintado equipado con fuente de luz COB LED y convertidor integrado. Disponible acabados: blanco y negro.

потолочный светильник из окрашенного алюминия. Светодиод на плате. С конвертером. Отделки: белая, черная



Architectural

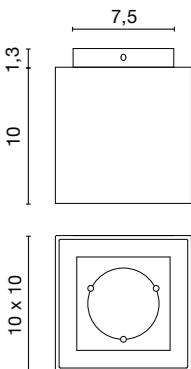

5561 alea led 0,7 kg

/xw Led 6,5W 844lm 2700K

/ww Led 6,5W 844lm 3000K

/w Led 6,5W 844lm 4000K



.01/XW .01/WW .01/W
.02/XW .02/WW .02/W

MOONLIGHT

design: ABS Studio

Architectural

Architectural

Lampade da parete o soffitto con emissione radiale.

Disponibile in due diametri: 50 e 70 cm, e tre tonalità di luce (2700, 3000 e 4000K)

Alimentatore integrato, versioni dimmerabili a richiesta.

La speciale finitura del disco in MDF permette la verniciatura dello stesso con le normali idropitture comunemente usate per tinteggiare.

Struttura in alluminio e diffusore interno in policarbonato opalino

La versione piccola è disponibile anche con disco a specchio.

Partendo da un unico punto di alimentazione è possibile creare composizioni intersecando più elementi grazie ad un apposito kit da ordinare separatamente.

Ceiling/Wall lamp for radial emission.

Available in two diameters: 50 and 70 cm and three light tones (2700, 3000 e 4000K). Converter on board, dimmable options upon request.

The MDF special finish can be easily painted with the standard water paint commonly used for interiors.

Frame in aluminum and internal diffuser in opal polycarbonate.

The smaller option is also available with a mirror disc.

Starting from a single electrical outlet it is possible to create a composition overlapping more elements by means of a specific kit to order separately.

Lampe à plafond/applique pour émission radiale.

Disponible dans deux diamètres 50 et 70 cm et trois différents tonalités de lumière (2700, 3000 et 4000K).

Convertisseur intégré, versions dimmables disponibles sur requête.

La finition spéciale du disque en MDF permet de le peindre avec les peintures à l'eau pour murs et plafonds.

Structure en aluminium et diffuseur interne en polycarbonate opalin.

La version plus petite est aussi disponible avec miroir en disque.

À partir d'un seul point d'alimentation on peut créer des configurations en superposent différents éléments grâce à un set d'accessoires spécifique à commander séparément.

Wand-/Deckenleuchte für Radial-strahlung. Verfügbar in zwei Durchmesser, 50 oder 70 cm, und drei Farbtemperaturen (2700, 3000 und 4000K).

Konverter an Bord, Dimmbarkeit auf Anfrage.

Dank die spezielle Fertigung der MDF-Scheibe, kann man es einfach mit die normalen Wasserfarben für Wände und Decken streichen.

Gestell aus Aluminium und Innendiffusor aus opalen Polykarbonat.

Die kleine Ausführung ist auch mit Spiegelscheibe verfügbar.

Von eine einzelne Leistungseinführung kann man überlappende Kompositionen von verschiedene Einheiten realisieren, dank einen Satz Zubehör(separat zu bestellen).

Lampada LED de pared y de techo para luz radial.

Disponible en dos diámetros, 50 o 70 cm, y con tres tonos de luz (2700, 3000 y 4000K). Convertidor incluido, versiones dimmables se realizan a pedido.

El acabado especial del disco de MDF permite de pintar lo mismo con pinturas al agua que normalmente se utilizan para paredes y interiores.

Estructura de aluminio y difusor interior de Policarbonato opalino.

La versión mas pequeña es disponible también con espejo.

A partir de un único punto de alimentación se pueden realizar configuraciones superponiendo mas elementos gracias a un set acesorio a pedir por separado.

Потолочный/настенный светильник равномерно рассеянного света.

Доступен в диаметрах 50 и 70 см и трех цветовых температурах (2700, 3000, 4000 K)

Блок питания встроенный, по запросу возможно диммирование.

Благодаря специальной отделке корпус светильника может быть легко окрашен краской на водной основе и адаптирован под конкретный интерьер.

Рамка из алюминия и отражатель внутри из сатинового поликарбоната.

Также доступны для заказа меньшие размеры с зеркальным диском.

От одного вывода питания можно создать композицию из перекрывающихся элементов с помощью специального приспособления, заказываемого отдельно.

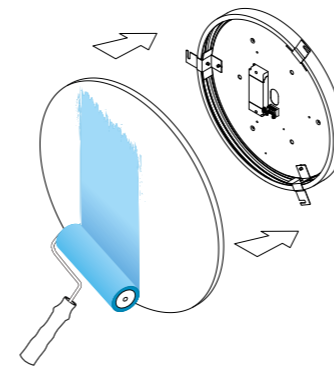
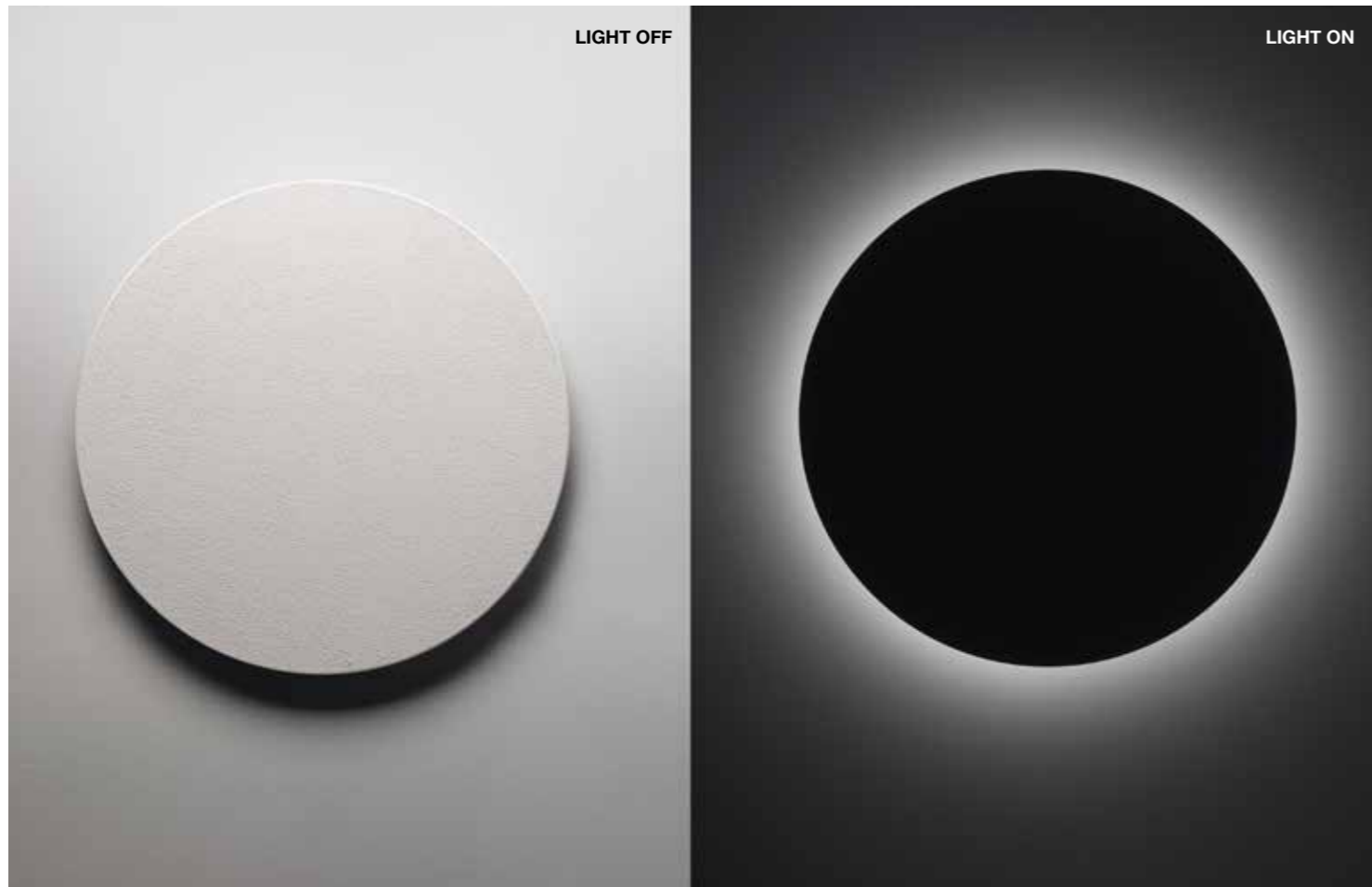

Montaggio elemento singolo
Installation of a single unit

4582
/WW Led 18W 2380lm 3000K
F IP 40

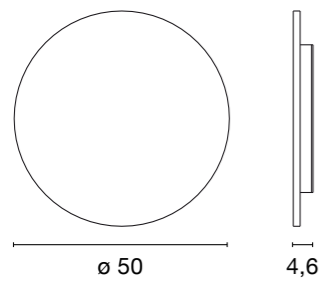

4583 3 kg
/WW Led 28,5W 2895lm 3000K
F IP 40

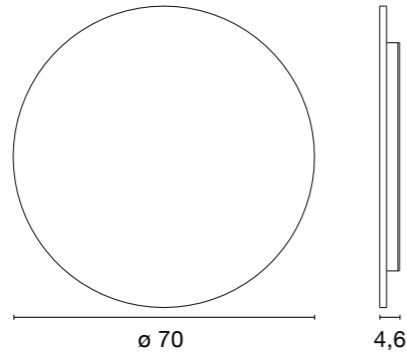

.01/WW 1,8 kg
.56/WW specchio - mirror 2,8 kg

.01/WW

Accessories



Distanziale per composizione
multipla
Kit for overlapping

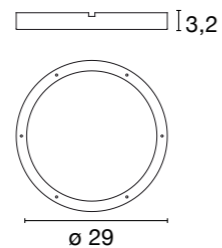

0963 0,3 kg
.01

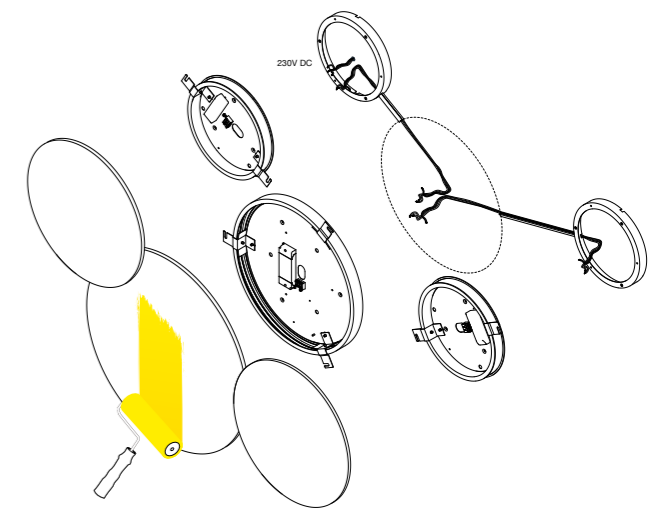
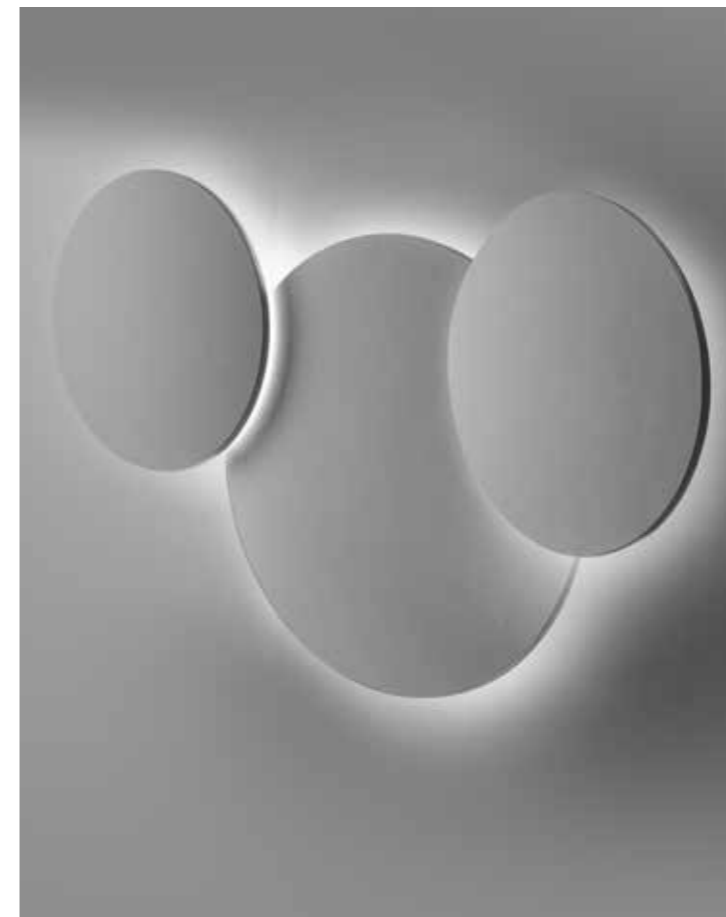

Montaggio elementi multipli
Installation of a group

MOONLIGHT

design: ABS Studio

MOONLIGHT

design: ABS Studio

Architectural

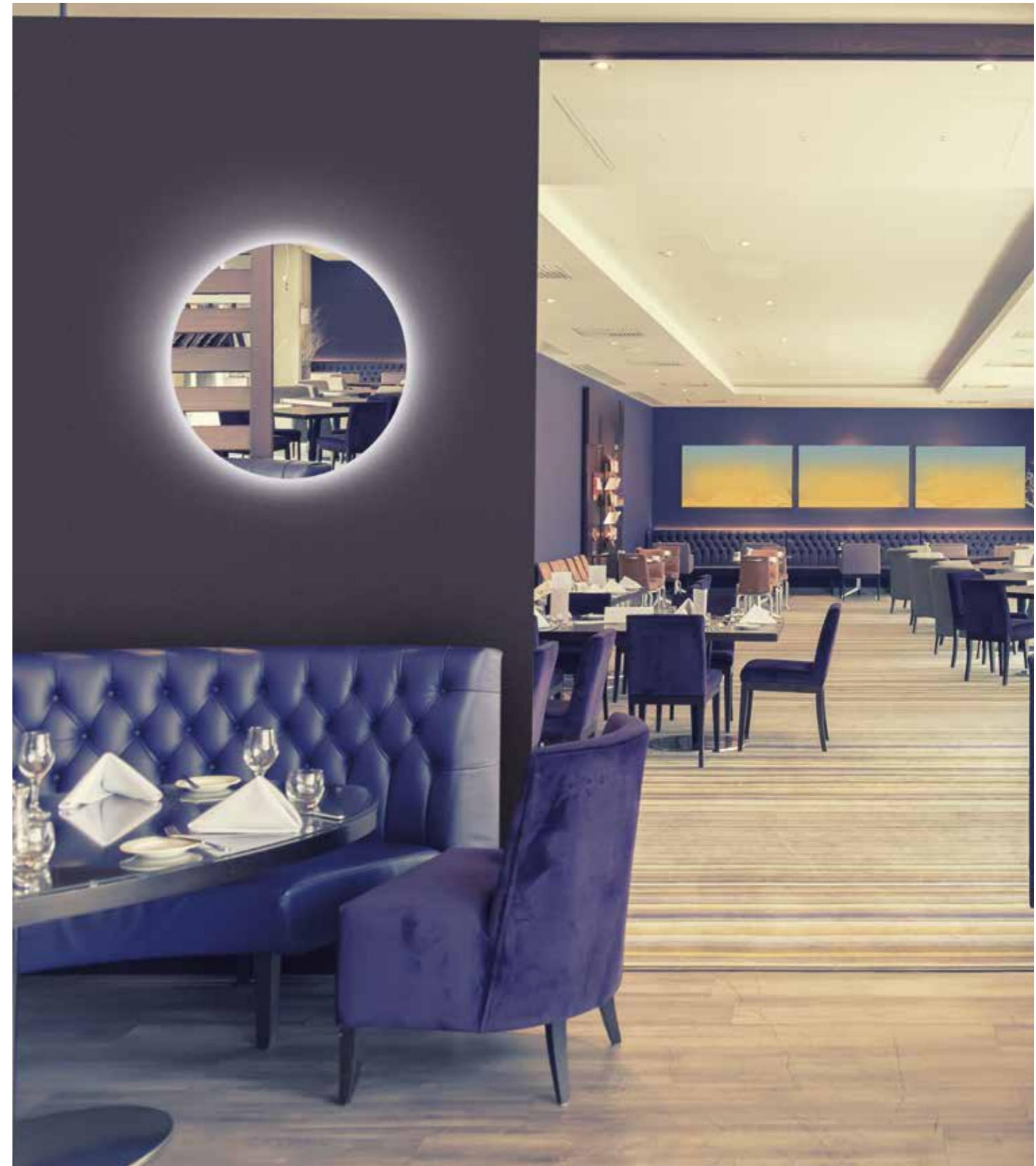
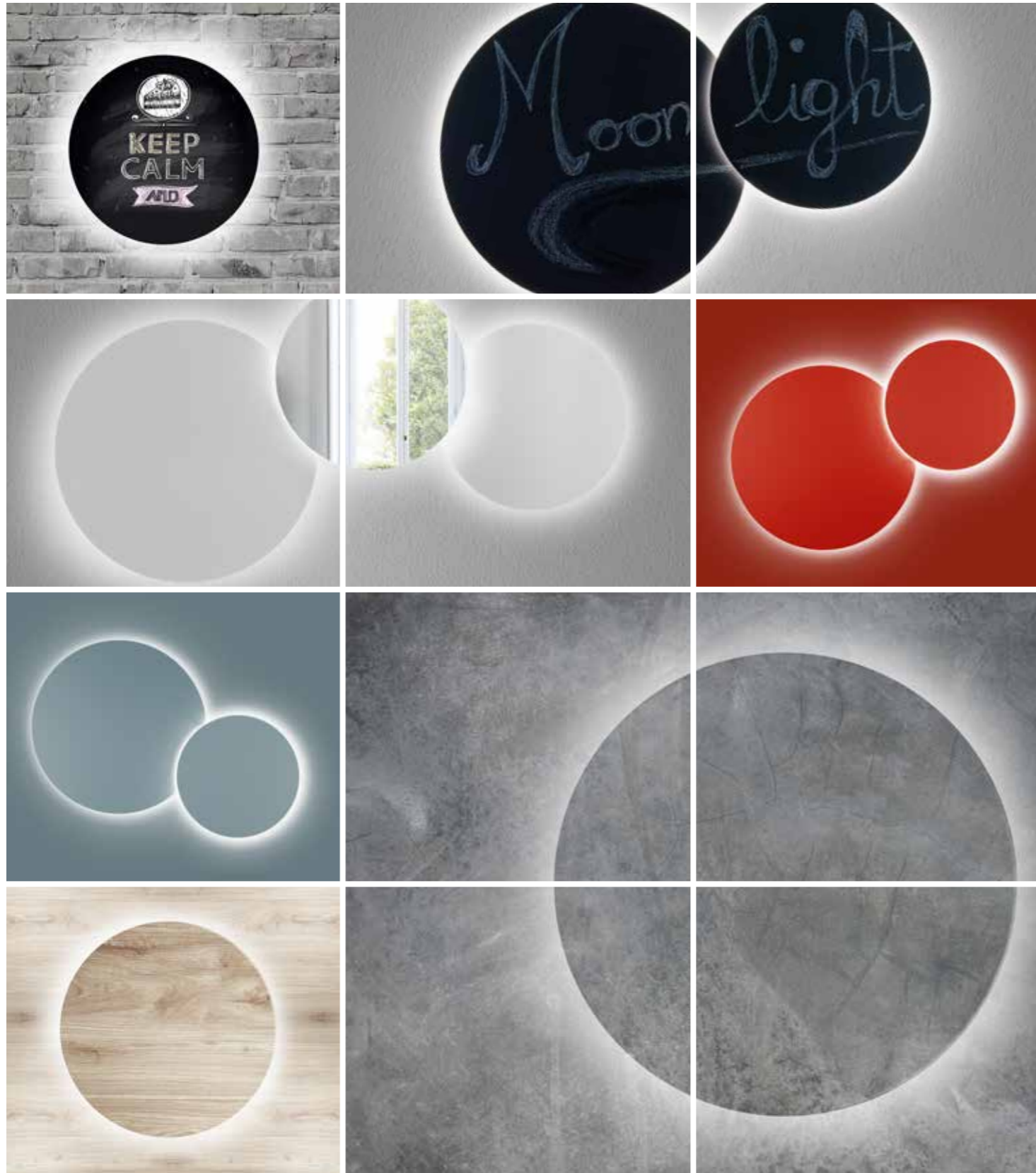

Architectural



LINEA MAXI - LINEA

design: U.T. EGOLUCE

Architectural

Sistema di apparecchi lineari LED da incasso con minitrim, il piccolo bordo in metacrilato consente un'installazione semplice che non richiede costose operazioni di rasatura, stuccatura e gestatura.

Profilo in metacrilato bianco satinato e dissipatore in alluminio anodizzato.

I singoli apparecchi sono realizzati in varie lunghezze da 12 a 302 cm con modularità ogni 10cm (vedi tabella).

Disponibili tre tonalità di luce (2700, 3000, 4000K) e versioni RGB.

A richiesta vengono realizzati tagli ad angolo e versioni con altre tonalità di luce.

Da ordinare separatamente: alimentatori, dimmer DALI/1...10V/PUSH, gruppi emergenza, casseforme per muratura (solo per mod. LINEA).

LINEA - Larghezza 2,7 cm.

La versione standard utilizza circuiti LED flessibili da 14,4W/m - 1700Lm/m nominali (4000K).

Versione ETL disponibile a richiesta

LINEAMAXI - Larghezza 5,4 cm.

La versione standard utilizza circuiti LED flessibili da 15W/m - 2000Lm/m nominali (4000K).

Lineare LED Einbauleuchten-system mit 'minitrim'. Der kleine Rahmen aus Methacrylat ermöglicht eine einfache und billige Installation ohne Gipsfertigung.

Profil aus satiniertem Methacrylat weiß und Kühlkörper aus Aluminium eloxiert.

Die einzelnen Elemente sind in verschiedenen Längen verfügbar: von 12 bis 302 cm. mit Modularität je 10 cm (siehe Tabelle).

Erhältlich in drei Lichtfarben (2700, 3000 oder 4000K) oder RGB.

Auf Anfrage vorbereiten wir Sonderausführungen mit eckeschnitt oder mit andere Lichtfarbe.

Separat zu bestellen: Konverter, dimmer DALI/1...10V/PUSH, Notbeleuchtung, Einbaudose (nur für LINEA).

LINEA - Breite 2,7 cm.

Die Standardversion ist mit flexible LED Leisten 14,4W/m - 1700Lm/m (4000K) versehen.

LINEA - Breite 5,4 cm.

Die Standardversion ist mit flexible LED Leisten 15W/m - 2000Lm/m (4000K) versehen.

System of recessed linear LED fixtures with minitrim, the small methacrylate trim allows easy installation avoiding expensive plastering operations.

Profile in white satin methacrylate and heatsink in anodized aluminum.

Fixtures are produced in different lengths from 12 to 302 cm with modularity every 10 cm (see table).

Three light tones available (2700, 3000, 4000K) and RGB options.

Upon request we prepare fixtures with angled cuts and other light tones.

To be ordered separately: converters, dimmer DALI/1...10V/PUSH, emergency kit, box for concrete(only for LINEA).

LINEA - width 2,7 cm.

The standard option is fitted with flexible LED strip 14,4W/m - 1700Lm/m gross output (4000K).

ETL version available upon request

LINEA MAXI - width 5,4 cm.

The standard option is fitted with flexible LED strip 15W/m - 2000Lm/m gross output (4000K).

Systema empotrable de aparatos LED lineares con 'minitrim', el pequeño marco de metacrilato permite una instalación simplificada y ahorra toda las operaciones de acabado del yeso.

Perfil de metacrilato satinado y disipador de calor en aluminio anodizado.

Los aparatos son producidos en diferentes larguras desde 12 hasta 302 cm y modularidad cada 10 cm (ver tabla).

Tres tonos de luz disponibles (2700, 3000 y 4000K) y RGB.

A pedido se realizan versiones con corte angular y otros tonos de luz.

A pedir por separado: Convertidor, dimmer DALI/1...10V/PUSH, luz de emergencia, caja para empotrar (solo por Linea).

LINEA - Ancho 2,7 cm.

Las versiones standard disfrutan un circuito LED 14,4W/m - 1700 Lm/m (4000K).

LINEA MAXI- Ancho 5,4 cm.

Las versiones standard disfrutan un circuito LED 15W/m - 2000 Lm/m (4000K).

Système d'appareils encastrables linéaires LED avec 'minitrim', la petite bordure en méthacrylate simplifie l'installation faisant aussi épargner frais de plâtrerie et rasage.

Profil en méthacrylate blanc satiné et dissipateur de chaleur en aluminium anodisé.

Les appareils sont produit dans différentes longueurs à partir de 12 jusqu'à 302 cm avec modularité 10cm (voir table).

Trois tonalité de lumière disponibles (2700, 3000, 4000K) et options RGB.

Sur requête nous réalisons appareils avec découpage angulaire et autres tonalité de lumière.

À commander séparément: convertisseur, dimmer DALI/1...10V/PUSH, kit lumière de secours, boîte d'encastrement pour murs pleins(seulement pour LINEA).

LINEA - largeur 2,7 cm.

La version standard est équipé d'un circuit LED flexible 14,4W/m - 1700Lm/m émission (4000K).

Version ETL disponible sur demande

LINEA MAXI - largeur 5,4 cm.

La version standard est équipé d'un circuit LED flexible 15W/m - 2000Lm/m émission (4000K).

Система встраиваемых линейных светодиодных светильников с тонкой рамкой из метакрилата, облегчающей установку светильника без сложных и затратных штукатурных работ.

Профиль из сатинированного белого метакрилата, теплоотвод из экструдированного алюминия.

Выпускается в различных стандартных длинах от 12 до 302 см с шагом 10 см (см. таблицу), трех цветовых температурах (2700, 3000 и 4000K) или RGB.

По запросу производятся светильники, которые можно стыковать под углом, а также в других цветовых температурах.

Отдельно заказываются: блоки питания, DALI/1...10V/PUSH, аварийные блоки, коробка для установки в бетон (только для серии LINEA).

LINEA - ширина 2,7 см.

Стандартная версия комплектуется гибкой светодиодной лентой LED strip 14,4 Вт/м, световой поток 1700лм/м (4000K).

LINEA MAXI - ширина 5,4 см.

Стандартная версия комплектуется гибкой светодиодной лентой LED strip 15,0 Вт/м, световой поток 2000лм/м (4000K).

Architectural

LINEA MAXI

design: U.T. EGOLUCE

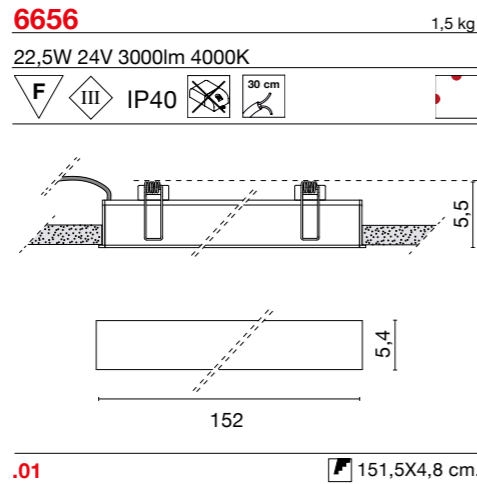
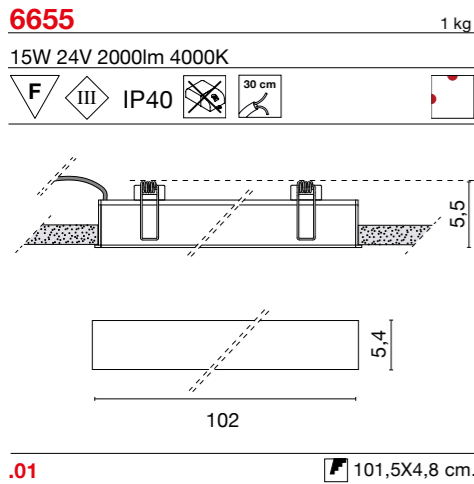

Opportunamente installato garantisce UGR < 19 (Indice unificato d'abbagliamento)
 Conveniently positioned grants an UGR < 19 (Unified Glare Rating)

Accessories



0242-100/200/300
 Profilo a L per cartongesso
 L profile for plasterboard

Drivers



CUSTOM SIZE

Tabella lunghezze disponibili a richiesta. Le misure si riferiscono alle lunghezze totali delle lampade comprese di tappi terminali.
 N.B. senza tappi: - 1 cm.
 Table of available lengths on request. Measures are referred to complete fixtures including closing heads.
 Attention: Without closing heads: - 1 cm.

cm.	watt	cm.	2700K (XW)	lm	3000K (WW)	lm	4000K (W)	lm	RGB
12	1,5W	11,5x4,8	A6655.01/10/XW	178	A6655.01/10/WW	190	A6655.01/10/W	200	A6655.01/10RGB
22	3W	21,5x4,8	A6655.01/20/XW	356	A6655.01/20/WW	380	A6655.01/20/W	400	A6655.01/20RGB
32	4,5W	31,5x4,8	A6655.01/30/XW	534	A6655.01/30/WW	570	A6655.01/30/W	600	A6655.01/30RGB
42	6W	41,5x4,8	A6655.01/40/XW	712	A6655.01/40/WW	760	A6655.01/40/W	800	A6655.01/40RGB
52	7,5W	51,5x4,8	A6655.01/50/XW	890	A6655.01/50/WW	950	A6655.01/50/W	1000	A6655.01/50RGB
62	9W	61,5x4,8	A6655.01/60/XW	1068	A6655.01/60/WW	1140	A6655.01/60/W	1200	A6655.01/60RGB
72	10,5W	71,5x4,8	A6655.01/70/XW	1246	A6655.01/70/WW	1330	A6655.01/70/W	1400	A6655.01/70RGB
82	12W	81,5x4,8	A6655.01/80/XW	1424	A6655.01/80/WW	1520	A6655.01/80/W	1600	A6655.01/80RGB
92	13,5W	91,5x4,8	A6655.01/90/XW	1604	A6655.01/90/WW	1710	A6655.01/90/W	1800	A6655.01/90RGB
102	15W	101,5x4,8	A6655.01/100/XW	1780	A6655.01/100/WW	1900	6655.01 ★	2000	6657.01 ★
112	16,5W	111,5x4,8	A6655.01/110/XW	1958	A6655.01/110/WW	2090	A6655.01/110/W	2200	A6655.01/110RGB
122	18W	121,5x4,8	A6655.01/120/XW	2136	A6655.01/120/WW	2280	A6655.01/120/W	2400	A6655.01/120RGB
132	19,5W	131,5x4,8	A6655.01/130/XW	2314	A6655.01/130/WW	2470	A6655.01/130/W	2600	A6655.01/130RGB
142	21W	141,5x4,8	A6655.01/140/XW	2492	A6655.01/140/WW	2660	A6655.01/140/W	2800	A6655.01/140RGB
152	22,5W	151,5x4,8	A6655.01/150/XW	2670	A6655.01/150/WW	2850	6656.01 ★	3000	6658.01 ★
162	24W	161,5x4,8	A6655.01/160/XW	2848	A6655.01/160/WW	3040	A6655.01/160/W	3200	A6655.01/160RGB
172	25,5W	171,5x4,8	A6655.01/170/XW	3026	A6655.01/170/WW	3230	A6655.01/170/W	3400	A6655.01/170RGB
182	27W	181,5x4,8	A6655.01/180/XW	3204	A6655.01/180/WW	3420	A6655.01/180/W	3600	A6655.01/180RGB
192	28,5W	191,5x4,8	A6655.01/190/XW	3382	A6655.01/190/WW	3610	A6655.01/190/W	3800	A6655.01/190RGB
202	30W	201,5x4,8	A6655.01/200/XW	3560	A6655.01/200/WW	3800	A6655.01/200/W	4000	A6655.01/200RGB
212	31,5W	211,5x4,8	A6655.01/210/XW	3738	A6655.01/210/WW	3990	A6655.01/210/W	4200	A6655.01/210RGB
222	33W	221,5x4,8	A6655.01/220/XW	3916	A6655.01/220/WW	4180	A6655.01/220/W	4400	A6655.01/220RGB
232	34,5W	231,5x4,8	A6655.01/230/XW	4094	A6655.01/230/WW	4370	A6655.01/230/W	4600	A6655.01/230RGB
242	36W	241,5x4,8	A6655.01/240/XW	4272	A6655.01/240/WW	4560	A6655.01/240/W	4800	A6655.01/240RGB
252	37,5W	251,5x4,8	A6655.01/250/XW	4450	A6655.01/250/WW	4750	A6655.01/250/W	5000	A6655.01/250RGB
262	39W	261,5x4,8	A6655.01/260/XW	4628	A6655.01/260/WW	4940	A6655.01/260/W	5200	A6655.01/260RGB
272	40,5W	271,5x4,8	A6655.01/270/XW	4806	A6655.01/270/WW	5130	A6655.01/270/W	5400	A6655.01/270RGB
282	42W	281,5x4,8	A6655.01/280/XW	4984	A6655.01/280/WW	5230	A6655.01/280/W	5600	A6655.01/280RGB
292	43,5W	291,5x4,8	A6655.01/290/XW	5162	A6655.01/290/WW	5510	A6655.01/290/W	5800	A6655.01/290RGB
302	45W	301,5x4,8	A6655.01/300/XW	5340	A6655.01/300/WW	5700	A6655.01/300/W	6000	A6655.01/300RGB

★ Articolo standard a catalogo - Standard catalogue item

LINEA MAXI

design: U.T. EGOLUCE

Architettura



Lunghezze superiori ai 3 metri si ottengono accostando i singoli elementi. Il foro d'incasso si calcola con la seguente formula:
 Configurations longer than 3 meters can be obtained by putting single fittings side by side in a row. The cutout length can be calculated with the formula hereunder:

Esempi - Examples 4,8xL cm.

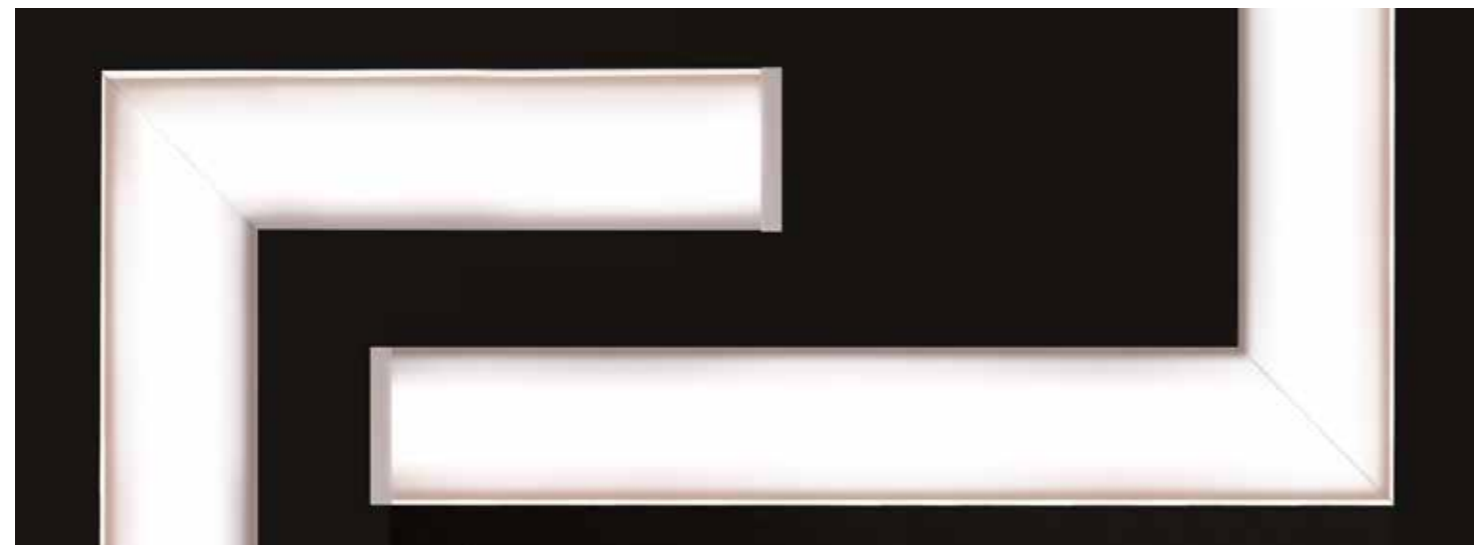
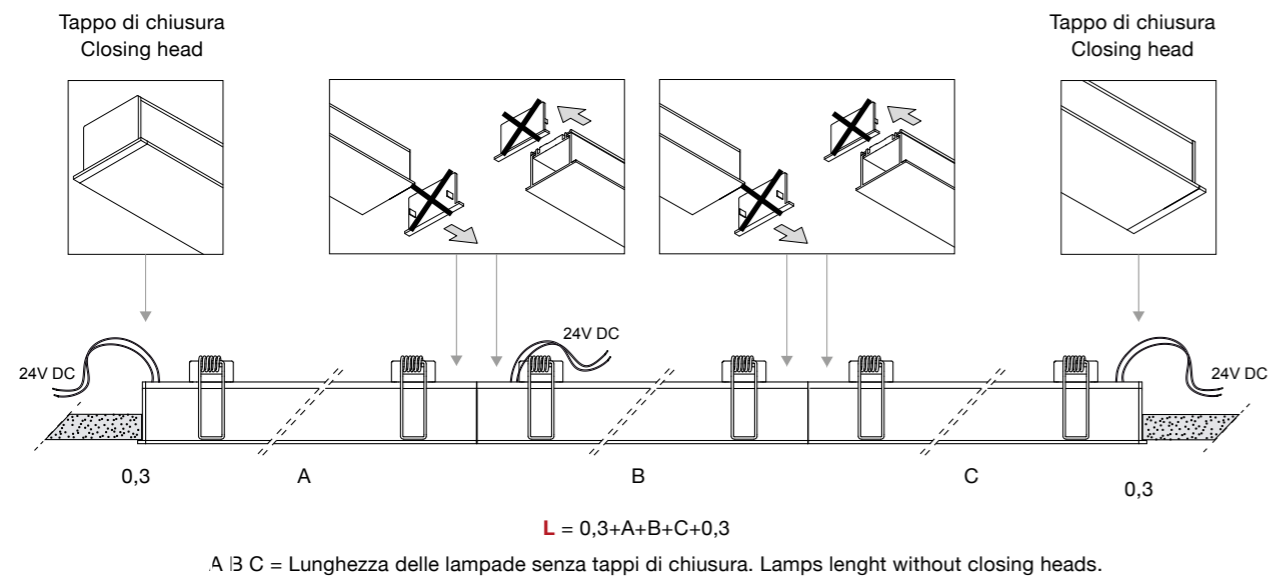

Su richiesta sono disponibili soluzioni angolari a 90°
 90° angled options are available upon request



Architettura



CUSTOM SIZE

Tabella lunghezze disponibili a richiesta. Le misure si riferiscono alle lunghezze totali delle lampade comprese di tappi terminali.

N.B. senza tappi: - 1 cm.

Table of available lengths on request. Measures are referred to complete fixtures including closing heads.

Attention: Without closing heads: - 1cm.

cm.	watt	cm.	2700K (XW)	lm	3000K (WW)	lm	4000K (W)	lm	RGB
12	1,4W	11,5x2,2	A6615.01/10/XW	150	A6615.01/10/WW	160	A6615.01/10/W	170	A6615.01/10RGB
22	2,9W	21,5x2,2	A6615.01/20/XW	300	A6615.01/20/WW	320	A6615.01/20/W	340	A6615.01/20RGB
32	4,3W	31,5x2,2	A6615.01/30/XW	450	A6615.01/30/WW	480	A6615.01/30/W	510	A6615.01/30RGB
42	5,8W	41,5x2,2	A6615.01/40/XW	600	A6615.01/40/WW	640	A6615.01/40/W	680	A6615.01/40RGB
52	7,2W	51,5x2,2	A6615.01/50/XW	750	A6615.01/50/WW	800	A6615.01/50/W	850	A6615.01/50RGB
62	8,6W	61,5x2,2	A6615.01/60/XW	900	A6615.01/60/WW	960	A6615.01/60/W	1020	A6615.01/60RGB
72	10,1W	71,5x2,2	A6615.01/70/XW	1050	A6615.01/70/WW	1120	A6615.01/70/W	1190	A6615.01/70RGB
82	11,5W	81,5x2,2	A6615.01/80/XW	1200	A6615.01/80/WW	1280	A6615.01/80/W	1360	A6615.01/80RGB
92	13W	91,5x2,2	A6615.01/90/XW	1350	A6615.01/90/WW	1440	A6615.01/90/W	1530	A6615.01/90RGB
102	14,4W	101,5x2,2	A6615.01/100/XW	1500	A6615.01/100/WW	1600	6615.01 *	1700	6617.01 *
112	15,8W	111,5x2,2	A6615.01/110/XW	1650	A6615.01/110/WW	1760	A6615.01/110/W	1870	A6615.01/110RGB
122	17,3W	121,5x2,2	A6615.01/120/XW	1800	A6615.01/120/WW	1920	A6615.01/120/W	2040	A6615.01/120RGB
132	18,7W	131,5x2,2	A6615.01/130/XW	1950	A6615.01/130/WW	2080	A6615.01/130/W	2210	A6615.01/130RGB
142	20,2W	141,5x2,2	A6615.01/140/XW	2100	A6615.01/140/WW	2240	A6615.01/140/W	2380	A6615.01/140RGB
152	21,6W	151,5x2,2	A6615.01/150/XW	2250	A6615.01/150/WW	2400	6616.01 *	2550	6618.01 *
162	23W	161,5x2,2	A6615.01/160/XW	2400	A6615.01/160/WW	2560	A6615.01/160/W	2720	A6615.01/160RGB
172	24,5W	171,5x2,2	A6615.01/170/XW	2550	A6615.01/170/WW	2720	A6615.01/170/W	2890	A6615.01/170RGB
182	25,9W	181,5x2,2	A6615.01/180/XW	2700	A6615.01/180/WW	2880	A6615.01/180/W	3060	A6615.01/180RGB
192	27,4W	191,5x2,2	A6615.01/190/XW	2850	A6615.01/190/WW	3040	A6615.01/190/W	3230	A6615.01/190RGB
202	28,8W	201,5x2,2	A6615.01/200/XW	3000	A6615.01/200/WW	3200	A6615.01/200/W	3400	A6615.01/200RGB
212	30,2W	211,5x2,2	A6615.01/210/XW	3150	A6615.01/210/WW	3360	A6615.01/210/W	3570	A6615.01/210RGB
222	31,7W	221,5x2,2	A6615.01/220/XW	3300	A6615.01/220/WW	3520	A6615.01/220/W	3740	A6615.01/220RGB
232	33,1W	231,5x2,2	A6615.01/230/XW	3450	A6615.01/230/WW	3680	A6615.01/230/W	3910	A6615.01/230RGB
242	34,6W	241,5x2,2	A6615.01/240/XW	3600	A6615.01/240/WW	3840	A6615.01/240/W	4080	A6615.01/240RGB
252	36W	251,5x2,2	A6615.01/250/XW	3750	A6615.01/250/WW	4000	A6615.01/250/W	4250	A6615.01/250RGB
262	37,4W	261,5x2,2	A6615.01/260/XW	3900	A6615.01/260/WW	4160	A6615.01/260/W	4420	A6615.01/260RGB
272	38,9W	271,5x2,2	A6615.01/270/XW	4050	A6615.01/270/WW	4320	A6615.01/270/W	4590	A6615.01/270RGB
282	40,3W	281,5x2,2	A6615.01/280/XW	4200	A6615.01/280/WW	4480	A6615.01/280/W	4760	A6615.01/280RGB
292	41,8W	291,5x2,2	A6615.01/290/XW	4350	A6615.01/290/WW	4640	A6615.01/290/W	4930	A6615.01/290RGB
302	43,2W	301,5x2,2	A6615.01/300/XW	4500	A6615.01/300/WW	4800	A6615.01/300/W	5100	A6615.01/300RGB

* Articolo standard a catalogo - Standard catalogue item

6615 0,5 kg

14,4W 24V 1700lm 4000K

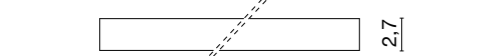
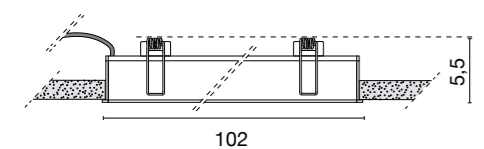

.01 101,5X2,2 cm.

Accessories



0242-100/200/300
Profilo a L per cartongesso
L profile for plasterboard

Drivers



0156 24V 25W 0160 24V 50W 0157 24V 72W 0162 24V 150W 0161/100 24V 100W 0110/DIM Dimmer 24V 0717/DIM60 Dimmer - 60W 0717/DIM100 Dimmer - 100W 0115/EM Emergency Unit

Cassaforma per calcestruzzo - Wallbox for concrete

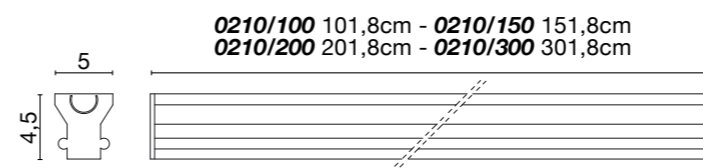

	cm.
0210/100	6x105x5cm
0210/150	6x155x5cm
0210/200	6x205x5cm
0210/300	6x305x5cm





Lunghezze superiori ai 3 metri si ottengono accostando i singoli elementi, il foro d'incasso si calcola con la seguente formula:
 Configurations longer than 3 meters can be obtained by putting single fittings side by side in a row, the cutout length can be calculated with the formula hereunder:

Esempi - Examples 2,2xL cm.

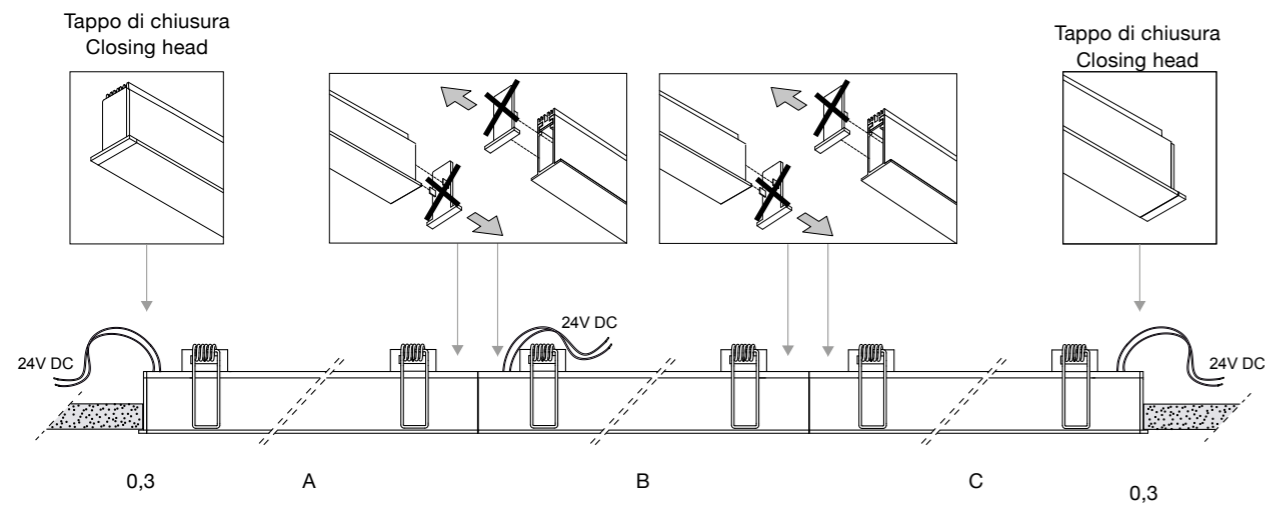

$$L = 0,3 + A + B + C + 0,3$$

A B C = Lunghezza delle lampade senza tappi di chiusura. Lamps length without closing heads.



Su richiesta sono disponibili soluzioni angolari a 90°
 90° angled options are available upon request

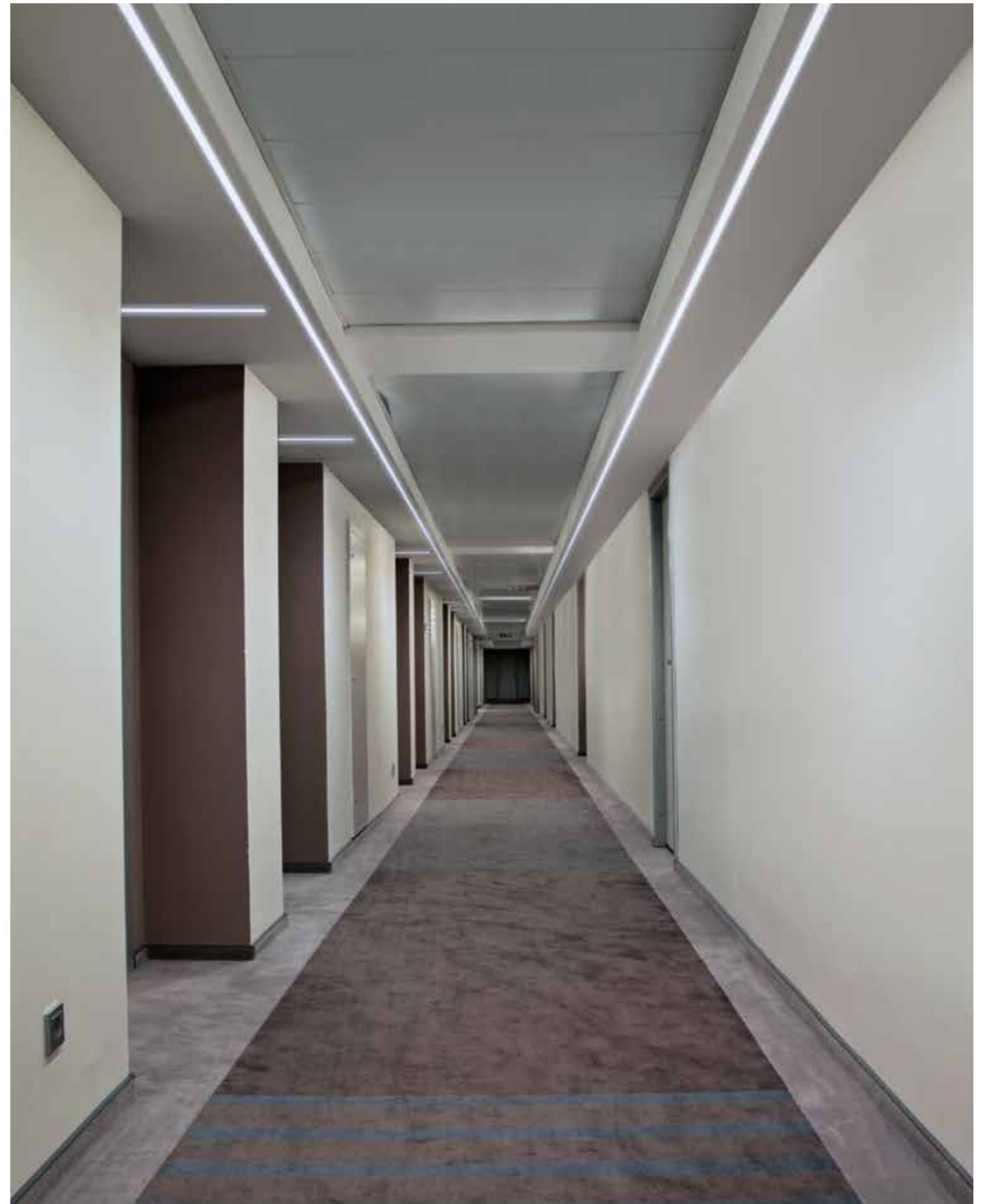

LINEA RGB - LINEA MAXI RGB

design: U.T. EGOLUCE

Architectural

6617 linea RGB 0,5 kg

14,4W 24V

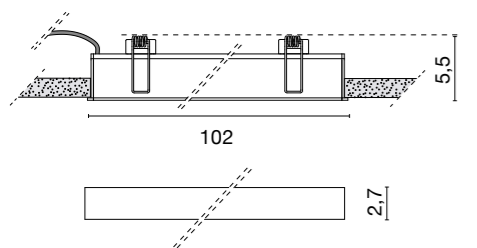

.01  101,5X2,2 cm.

6618 linea RGB 0,7 kg

21,6W 24V

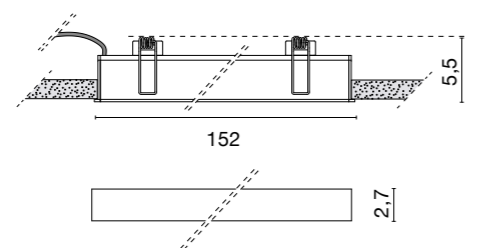
.01  151,5X2,2 cm.

6657 linea maxi RGB 0,5 kg

14,4W 24V

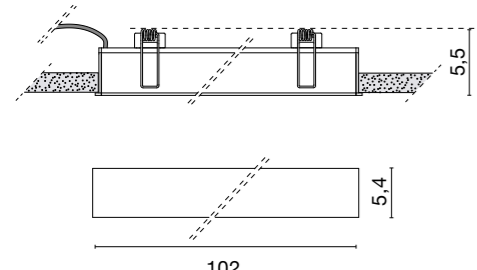

.01  101,5X4,8 cm.

6658 linea maxi RGB 0,7 kg

21,6W 24V

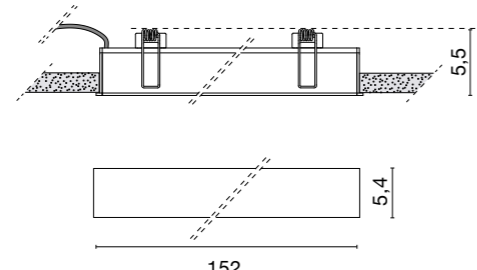

.01  151,5X4,8 cm.

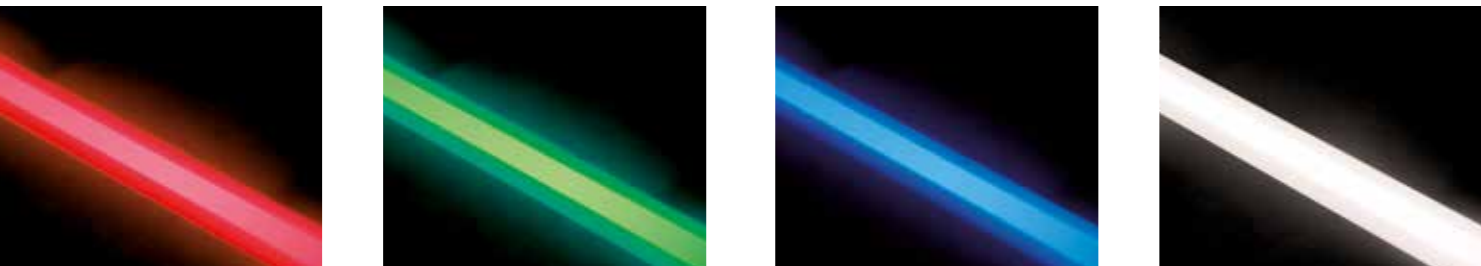

Accessories



0210-100/150/200/300
 Cassafirma per calcestruzzo (solo per Linea)
 Wallbox for concrete (only for Linea)



0242-100/200/300
 Profilo a L per cartongesso
 L profile for plasterboard

Drivers



0164 Driver RGB 22W **0167** Driver RGB 120W **0163** IR Sensor **0165** IR Remote Controller **0166** Sinc. Cable



Architectural

PHANTOM - PHANTOM MAXI

design: U.T. EGOLUCE

Architectural



Sistemi di apparecchi LED lineari da incasso a scomparsa totale per installazione in controsoffitti e pareti in cartongesso.

Profilo in estruso di alluminio verniciato bianco.

I sistemi si compongono di moduli lineari con lunghezze variabili (vedi tabelle) completi di circuiti LED e converter.

Da ordinare separatamente: testate di chiusura in policarbonato, giunti e diffusore in metacrilato satinato.

Due tonalità di luce disponibili: 3000K e 4000K; versioni dimmerabili realizzabili a richiesta.

PHANTOM – larghezza 4 cm.

Utilizza circuiti LED da 3446 Lm/m nominali (4000K).

Accessori disponibili: giunzioni angolari 90°, a T ed a croce

PHANTOM MAXI - larghezza 9 cm.

Utilizza circuiti LED da 6893 Lm/m nominali (4000K). Accessori disponibili: giunti angolari 90° e diffusore prismatico ad alta efficienza luminosa che garantisce la massima resa ed il controllo dell'abbagliamento.

Systems of trimless LED linear fixtures to be recessed into plasterboard false ceilings and walls.

Extruded aluminum profile, white finish.

Systems are composed of linear fixtures available in different lengths (see table) complete with LED circuits and onboard converter.

To be ordered separately: polycarbonate end pieces, joints and methacrylate diffuser. Two light tones available: 3000K and 4000K; dimmable options upon request.

PHANTOM – width 4cm.

Is fitted with LED circuits providing nominally 3446 Lm/m (4000K). Corner 90°, T shaped and Cross shaped joints are available as accessories.

PHANTOM MAXI – width 9 cm.

Is fitted with LED circuits providing nominally 6893 Lm/m (4000K). Corner 90° and Hi-efficacy prismatic diffuser for maximum effectiveness and glare control are available as accessories.

Systèmes linéaires d'appareils encastrables sans cadre pour installation dans des faux plafonds en placo-plâtre. Profil en alu extrudé verni blanc.

Les systèmes se composent de modules linéaires en plusieurs longueurs (voir tableau) avec circuits LED et convertisseurs inclus.

À commander séparément : embouts terminales en polycarbonate, joints et écran en Méthacrylate satin.

Deux tonalités de lumière disponibles : 3000K et 4000K, versions dimmables sur demande.

PHANTOM – largeur 4 cm.

Circuits LED qui délivre nominalemt 3446 Lm/m (4000K). Angles à 90°, Joints à T et en croix sont livrables comme accessoires .

PHANTOM MAXI – largeur 9 cm.

Circuits LED qui délivre nominalemt 6893 Lm/m (4000K). Angles à 90° et diffuseur prismatique haute efficacité pour control de l'éblouissement sont livrables comme accessoires .

Rahmenlose linear LED Einbauleuchten Systemen zur Einsetzung im Zwischendecken und Wände aus Gipskarton. Profil aus matt weiß lackiertem Aluminium.

Die Systemen bestehen aus Modulen in verschiedene Länge(s.Tabelle) komplett mit LED Platine und Konverter.

Separat zu bestellen: Endteile aus Polycarbonat, Verbindungsteile und Diffusor aus satiniertem Methacrylat.

Verfügbar in Zwei Lichtfarben: 3000K und 4000K, dimmbare Ausführungen auf Anfrage.

PHANTOM – Breite 4 cm.

Bestückt mit LED Platine die 3446 Lm/m (4000K) Lichtstrom brutto ergeben.

Zubehören: 90° Winkel, T förmige Verbindung oder Kreuz-verbinding .

PHANTOM MAXI – Breite 9 cm.

Bestückt mit LED Platine die 6893 Lm/m (4000K) Lichtstrom brutto ergeben.

Bestellbare Zubehören: 90° Winkel, Hocheffizient Prism-diffusor für Entblendung.

Sistemas de aparatos LED lineares sin marco para instalacion en falsos techos y paredes de pladur.

Perfil de aluminio trefilado pintado blanco.

Los sistemas se componen de modules lineares de varios largos (véase la tabla) con circuito LED y convertidor incluido.

Se deben pedir por separado: Terminales en policarbonato, enganches y difusor en metacrilato satinado.

Dos temperaturas de color de luz disponibles: 3000K y 4000K, versiones arreglables con dimmer se realizan a pedido.

PHANTOM – 4 cm. de ancho

Utiliza placa de led que entrega 3446 Lm/m nominales (4000K). Acesorios disponibles: perfil ángular 90°, perfil a T y a cruz.

PHANTOM MAXI – 9 cm. de ancho

Utiliza placa de led que entrega 6893Lm/m nominales (4000K). Acesorios disponibles: perfil ángular 90° y difusor prismático de alta eficiencia para maximo rendimiento y control del deslumbramiento.

Система встраиваемых без окантовки линейных светодиодных светильников, могут устанавливаться в гипсокартонные потолки и стены.

Профиль из экструдированного алюминия, окрашенного в белый цвет.

Можно объединять в системы светильники различных длин (см. таблицу), блок питания встроенный.

Отдельно заказывается: заглушки из поликарбоната, переходники и рассеиватель из метакрилата.

Два варианта цветовой температуры: теплая (3000K) и холодная (4000K), диммируемая версия по запросу.

PHANTOM – ширина 4 см.

Оснащен светодиодным модулем со световым потоком 3446 лм/м (4000K).

Доступны соединители: угловые 90°, Т и Х - образные

PHANTOM MAXI – ширина 9 см.

Оснащен светодиодным модулем со световым потоком 6893 лм/м (4000K). Угловые соединители на 90° и высокоэффективный призматический рассеиватель для максимальной эффективности и контроля ослепленности доступны в качестве аксессуаров.

PHANTOM

design: U.T. EGOLUCE

6650 phantom sistema 1 kg

/WW Led 12,5W 1840lm 3000K

/W Led 12,5W 1930lm 4000K

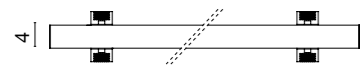
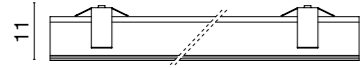

56,5

.01/W .01/WW



CUSTOM SIZE

Tabella lunghezze disponibili a richiesta. Lunghezza delle lampade senza tappi di chiusura.
Table of available lengths on request. Lamps length without closing heads.

cm.	watt	3000K (WW)	lm	4000K (W)	lm
★ 56,5	12,5W	6650.01/WW	1840	6650.01/W	1930
84,5	18,8W	A6650.01/85/WW	2770	A6650.01/85/W	2910
112,5	25W	A6650.01/113/WW	3080	A6650.01/113/W	3860
140,5	31,3W	A6650.01/141/WW	4610	A6650.01/141/W	4840
168,5	37,5W	A6650.01/169/WW	5520	A6650.01/169/W	5790
196,5	43,8W	A6650.01/197/WW	6450	A6650.01/197/W	6770
224,5	50W	A6650.01/225/WW	7360	A6650.01/225/W	7720

★ Articolo standard a catalogo - Standard catalogue item

FORO INCASSO - CUTOUT

La lunghezza totale del foro d'incasso si ottiene aggiungendo 1,5 cm alla somma delle lunghezze dei singoli pezzi (vedi schema pagina pag. 88).
Total length of the cutout is obtained by adding 1,5 cm to the sum of each component length (see page 88).

6649 phantom sistema DIMM 1...10V 1 kg

/WW Led 12,5W 1840lm 3000K

/W Led 12,5W 1930lm 4000K

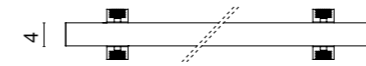
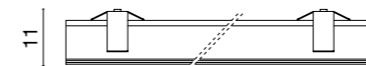

56,5

.01/W .01/WW

6653 phantom sistema DIMM DALI 1 kg

/WW Led 12,5W 1840lm 3000K

/W Led 12,5W 1930lm 4000K

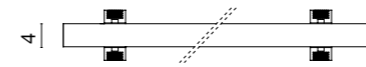

56,5

.01/W .01/WW

CUSTOM SIZE

Tabella lunghezze disponibili a richiesta. Lunghezza delle lampade senza tappi di chiusura.
Table of available lengths on request. Lamps length without closing heads.

cm.	watt	3000K (WW)	lm	4000K (W)	lm
★ 56,5	12,5W	6649.01/WW	1840	6649.01/W	1930
84,5	18,8W	A6649.01/85/WW	2770	A6649.01/85/W	2910
112,5	25W	A6649.01/113/WW	3080	A6649.01/113/W	3860
140,5	31,3W	A6649.01/141/WW	4610	A6649.01/141/W	4840
168,5	37,5W	A6649.01/169/WW	5520	A6649.01/169/W	5790
196,5	43,8W	A6649.01/197/WW	6450	A6649.01/197/W	6770
224,5	50W	A6649.01/225/WW	7360	A6649.01/225/W	7720

★ Articolo standard a catalogo - Standard catalogue item

FORO INCASSO - CUTOUT

La lunghezza totale del foro d'incasso si ottiene aggiungendo 1,5 cm alla somma delle lunghezze dei singoli pezzi (vedi schema pagina 88).
Total length of the cutout is obtained by adding 1,5 cm to the sum of each component length (see page 88).

CUSTOM SIZE

Tabella lunghezze disponibili a richiesta. Lunghezza delle lampade senza tappi di chiusura.
Table of available lengths on request. Lamps length without closing heads.

cm.	watt	3000K (WW)	lm	4000K (W)	lm
★ 56,5	12,5W	6653.01/WW	1840	6653.01/W	1930
84,5	18,8W	A6653.01/85/WW	2770	A6653.01/85/W	2910
112,5	25W	A6653.01/113/WW	3080	A6653.01/113/W	3860
140,5	31,3W	A6653.01/141/WW	4610	A6653.01/141/W	4840
168,5	37,5W	A6653.01/169/WW	5520	A6653.01/169/W	5790
196,5	43,8W	A6653.01/197/WW	6450	A6653.01/197/W	6770
224,5	50W	A6653.01/225/WW	7360	A6653.01/225/W	7720

★ Articolo standard a catalogo - Standard catalogue item

FORO INCASSO - CUTOUT

La lunghezza totale del foro d'incasso si ottiene aggiungendo 1,5 cm alla somma delle lunghezze dei singoli pezzi (vedi schema pagina 88).
Total length of the cutout is obtained by adding 1,5 cm to the sum of each component length (see page 88).

Accessories



Angolo 90° - 90° Corner

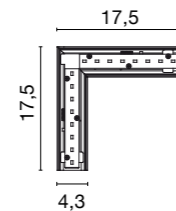

0971 Angolo 90° - 90° Corner 0,7 kg

/WW Led 6,3W 930lm 3000K

/W Led 6,3W 980lm 4000K

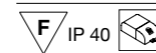

.01/WW .01/W



Giunzione a T - T joint

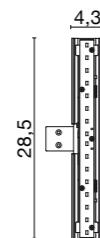

0972 Giunzione a T - T joint 0,7kg

/WW Led 6,3W 930lm 3000K

/W Led 6,3W 980lm 4000K



.01/WW .01/W



Giunzione a croce - Cross joint

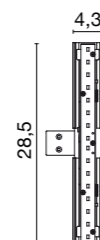

0973 Giunzione a croce - Cross joint 0,7 kg

/WW Led 6,3W 930lm 3000K

/W Led 6,3W 980lm 4000K

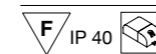

.01/WW .01/W



Diffusore - Diffuser

0845/200

L. 200cm

0845/300

L. 300cm

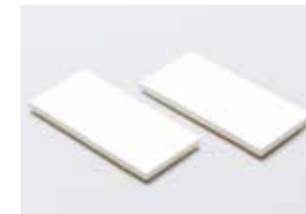

2 testate di chiusura.
2 closing heads.

0290

.01



Giunto con cavi
Connector with wires

0291

.01

0973
Giunzione a croce - Cross joint 0,7 kg
.01/WW .01/W

0290
2 testate di chiusura.
2 closing heads
.01

0972
Giunzione a T - T joint 0,7kg
.01/WW .01/W

0291
Giunto - Connector

0971
Angolo 90° - 90° Corner 0,7 kg
.01/WW .01/W

0845/200
Diffusore - Diffuser
L. 200cm

0845/300
Diffusore - Diffuser
L. 300cm

PHANTOM

design: U.T. EGOLUCE

Architectural



Lunghezze superiori ai 224,5 cm si ottengono accostando i singoli elementi, il foro d'incasso si calcola con la seguente formula:
Configurations longer than 224,5 cm can be obtained by putting single fittings side by side in a row, the cutout length can be calculated with the formula hereunder:

Esempi - Examples 4,7xL cm.

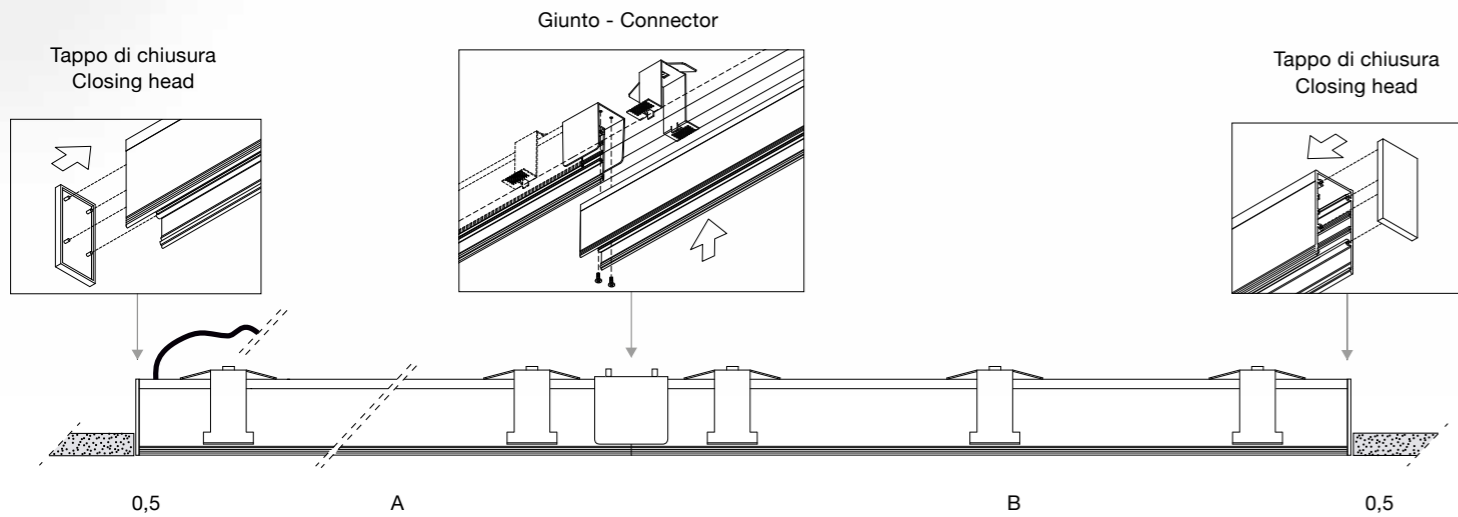

$$L = (0,5+A+B+0,5) + 0,5$$

A B ... = Lunghezza delle lampade senza tappi di chiusura. Lamps length without closing heads.



Architectural



PHANTOM MAXI

design: U.T. EGOLUCE

6648 phantom maxi sistema 2,1 kg

/WW Led 25W 3670lm 3000K

/W Led 25W 3860lm 4000K

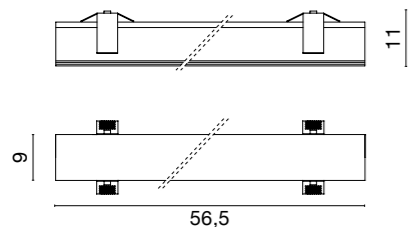

.01/W .01/WW 9,7x L cm.



CUSTOM SIZE

Tabella lunghezze disponibili a richiesta. Lunghezza delle lampade senza tappi di chiusura.
Table of available lengths on request. Lamps length without closing heads.

cm.	watt	3000K (WW)	lm	4000K (W)	lm
★ 56,5	25W	6648.01/WW	3670	6648.01/W	3860
84,5	37,5W	A6648.01/85/WW	5510	A6648.01/85/W	5790
112,5	50W	A6648.01/113/WW	7340	A6648.01/113/W	7720

★ Articolo standard a catalogo - Standard catalogue item

FORO INCASSO - CUTOUT

La lunghezza totale del foro d'incasso si ottiene aggiungendo 1,5 cm alla somma delle lunghezze dei singoli pezzi (vedi schema pagina 96).
Total length of the cutout is obtained by adding 1,5 cm to the sum of each component length (see page 96).

6659

phantom maxi sistema DIMM 1...10V 2,1 kg

/WW Led 25W 3670lm 3000K

/W Led 25W 3860lm 4000K

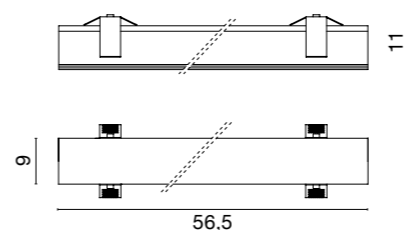
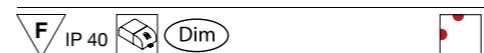

.01/W .01/WW 9,7x L cm.

6662

phantom maxi sistema DIMM DALI 2,1 kg

/WW Led 25W 3670lm 3000K

/W Led 25W 3860lm 4000K

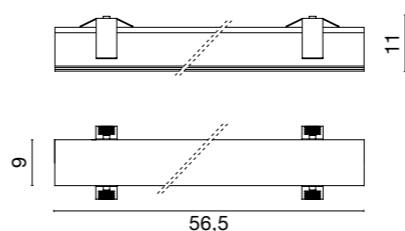

.01/W .01/WW 9,7x L cm.

CUSTOM SIZE

Tabella lunghezze disponibili a richiesta. Lunghezza delle lampade senza tappi di chiusura.
Table of available lengths on request. Lamps length without closing heads.

cm.	watt	3000K (WW)	lm	4000K (W)	lm
★ 56,5	25W	6659.01/WW	3670	6659.01/W	3860
84,5	37,5W	A6659.01/85/WW	5510	A6659.01/85/W	5790
112,5	50W	A6659.01/113/WW	7340	A6659.01/113/W	7720

★ Articolo standard a catalogo - Standard catalogue item

FORO INCASSO - CUTOUT

La lunghezza totale del foro d'incasso si ottiene aggiungendo 1,5 cm alla somma delle lunghezze dei singoli pezzi (vedi schema pagina 96).
Total length of the cutout is obtained by adding 1,5 cm to the sum of each component length (see page 96).

CUSTOM SIZE

Tabella lunghezze disponibili a richiesta. Lunghezza delle lampade senza tappi di chiusura.
Table of available lengths on request. Lamps length without closing heads.

cm.	watt	3000K (WW)	lm	4000K (W)	lm
★ 56,5	25W	6662.01/WW	3670	6662.01/W	3860
84,5	37,5W	A6662.01/85/WW	5510	A6662.01/85/W	5790
112,5	50W	A6662.01/113/WW	7340	A6662.01/113/W	7720

★ Articolo standard a catalogo - Standard catalogue item

FORO INCASSO - CUTOUT

La lunghezza totale del foro d'incasso si ottiene aggiungendo 1,5 cm alla somma delle lunghezze dei singoli pezzi (vedi schema pagina 96).
Total length of the cutout is obtained by adding 1,5 cm to the sum of each component length (see page 96).

Accessories



Angolo 90° - 90° Corner

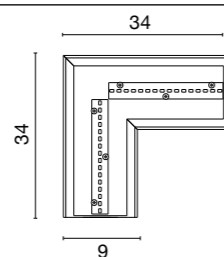

0981

0,7 kg

/WW Led 25W 3670lm 3000K

/W Led 25W 3860lm 4000K

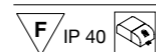

.01/WW .01/W



2 testate di chiusura.
2 closing heads.

0892

.01



Giunti con cavi
Connectors with wires

0293



Diffusore - Diffuser

0926/200

L. 200cm

0926/300

L. 300cm

PHANTOM MAXI PLUS

design: U.T. EGOLUCE

6663 phantom maxi sistema plus 2,1 kg

/ww Led 25W 3670lm 3000K

/w Led 25W 3860lm 4000K

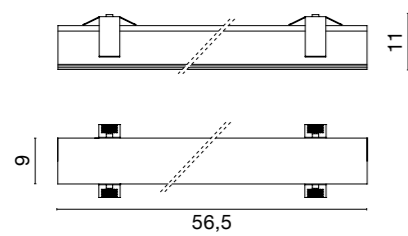

.01/W .01/WW 9,7x L cm.



CUSTOM SIZE

Tabella lunghezze disponibili a richiesta. Lunghezza delle lampade senza tappi di chiusura.
Table of available lengths on request. Lamps length without closing heads.

cm.	watt	3000K (WW)	lm	4000K (W)	lm
★ 56,5	25W	6663.01/WW	3670	6663.01/W	3860
84,5	37,5W	A6663.01/85/WW	5510	A6663.01/85/W	5790
112,5	50W	A6663.01/113/WW	7340	A6663.01/113/W	7720

★ Articolo standard a catalogo - Standard catalogue item

FORO INCASSO - CUTOUT

La lunghezza totale del foro d'incasso si ottiene aggiungendo 1,5 cm alla somma delle lunghezze dei singoli pezzi (vedi schema pagina 96).
Total length of the cutout is obtained by adding 1,5 cm to the sum of each component length (see page 96).

Opportunamente installato garantisce UGR < 19
Conveniently positioned grants an UGR < 19 (Unified Glare Rating)

6664

phantom maxi sistema plus DIMM 1...10V 2,1 kg

/ww Led 25W 3670lm 3000K

/w Led 25W 3860lm 4000K

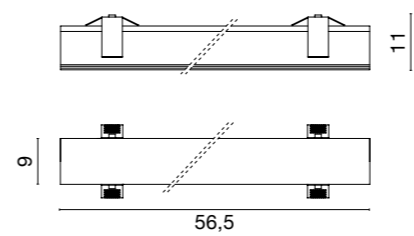
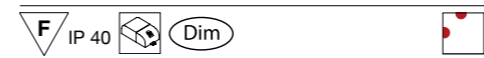

.01/W .01/WW 9,7x L cm.

6665

phantom maxi sistema plus DIMM DALI 2,1 kg

/ww Led 25W 3670lm 3000K

/w Led 25W 3860lm 4000K

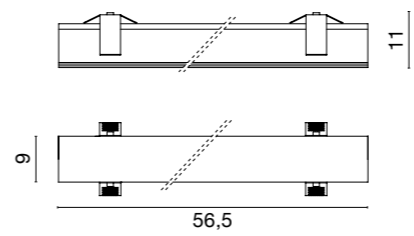

.01/W .01/WW 9,7x L cm.

CUSTOM SIZE

Tabella lunghezze disponibili a richiesta. Lunghezza delle lampade senza tappi di chiusura.
Table of available lengths on request. Lamps length without closing heads.

cm.	watt	3000K (WW)	lm	4000K (W)	lm
★ 56,5	25W	6664.01/WW	3670	6664.01/W	3860
84,5	37,5W	A6664.01/85/WW	5510	A6664.01/85/W	5790
112,5	50W	A6664.01/113/WW	7340	A6664.01/113/W	7720

★ Articolo standard a catalogo - Standard catalogue item

FORO INCASSO - CUTOUT

La lunghezza totale del foro d'incasso si ottiene aggiungendo 1,5 cm alla somma delle lunghezze dei singoli pezzi (vedi schema pagina 96).
Total length of the cutout is obtained by adding 1,5 cm to the sum of each component length (see page 96).

Opportunamente installato garantisce UGR < 19
Conveniently positioned grants an UGR < 19 (Unified Glare Rating)

CUSTOM SIZE

Tabella lunghezze disponibili a richiesta. Lunghezza delle lampade senza tappi di chiusura.
Table of available lengths on request. Lamps length without closing heads.

cm.	watt	3000K (WW)	lm	4000K (W)	lm
★ 56,5	25W	6665.01/WW	3670	6665.01/W	3860
84,5	37,5W	A6665.01/85/WW	5510	A6665.01/85/W	5790
112,5	50W	A6665.01/113/WW	7340	A6665.01/113/W	7720

★ Articolo standard a catalogo - Standard catalogue item

FORO INCASSO - CUTOUT

La lunghezza totale del foro d'incasso si ottiene aggiungendo 1,5 cm alla somma delle lunghezze dei singoli pezzi (vedi schema pagina 96).
Total length of the cutout is obtained by adding 1,5 cm to the sum of each component length (see page 96).

Opportunamente installato garantisce UGR < 19
Conveniently positioned grants an UGR < 19 (Unified Glare Rating)

Accessories



Angolo 90° - 90° Corner

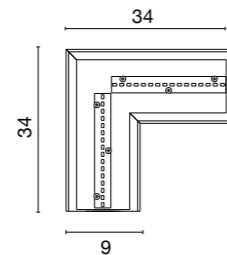

0981/PLUS 0,7 kg

/ww Led 25W 3670lm 3000K

/w Led 25W 3860lm 4000K



.01/WW .01/W



2 testate di chiusura.
2 closing heads.

0892

.01



Giunti con cavi
Connectors with wires

0293



Schermo alta efficienza
High efficiency diffuser

0870/200

L. 200cm

0870/300

L. 300cm

PHANTOM MAXI - PHANTOM MAXI PLUS

design: U.T. EGOLUCE

Architettura

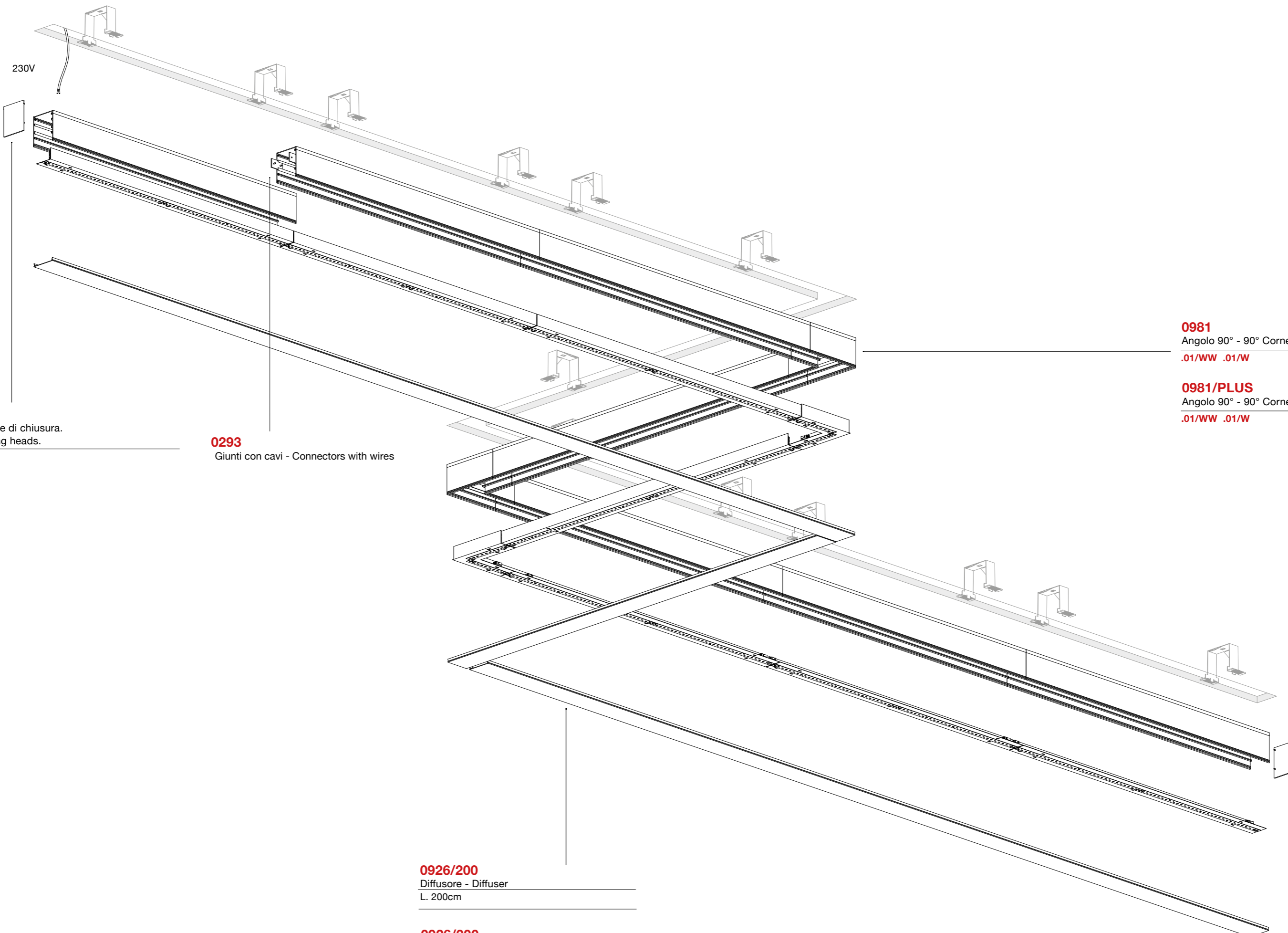

230V

0892
2 testate di chiusura.
2 closing heads.
.01

0293
Giunti con cavi - Connectors with wires

0981
Angolo 90° - 90° Corner 0,7 kg
.01/WW .01/W

0981/PLUS
Angolo 90° - 90° Corner 0,7 kg
.01/WW .01/W

0926/200
Diffusore - Diffuser
L. 200cm

0926/300
Diffusore - Diffuser
L. 300cm

PHANTOM MAXI - PHANTOM MAXI PLUS

design: U.T. EGOLUCE

Lunghezze superiori ai 224,5 cm si ottengono accostando i singoli elementi, il foro d'incasso si calcola con la seguente formula:
Configurations longer than 224,5 cm can be obtained by putting single fittings side by side in a row, the cutout length can be calculated with the formula hereunder:

Esempi - Examples  9,7xL cm.

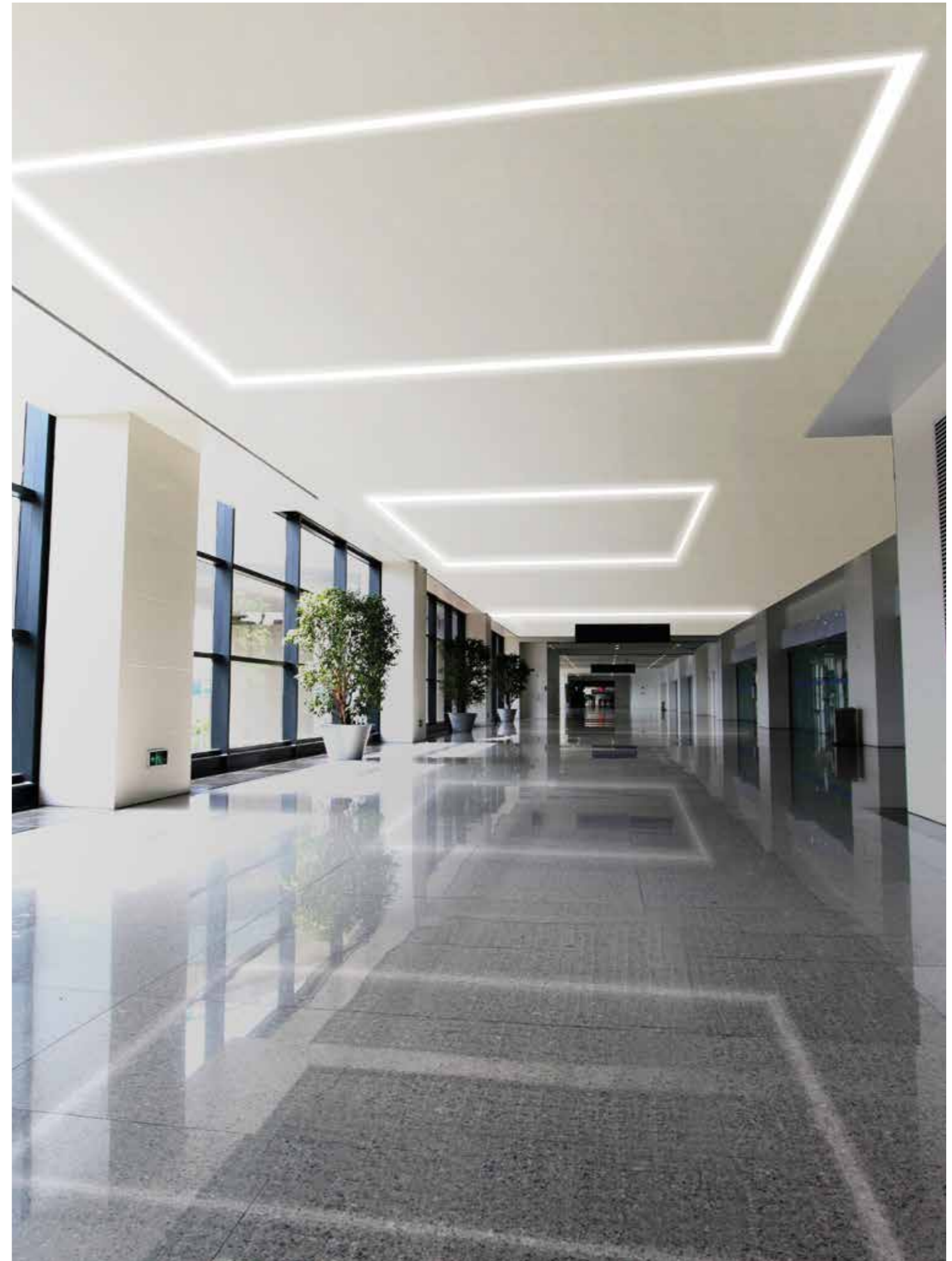

TRIMLESS LIGHTS

Architectural

Apparecchi da incasso a scomparsa totale per installazione in controsoffitti di cartongesso.
Disponibili in varie forme e dimensioni e con differenti proposte di luce.
Corpo in alluminio o metallo zincato verniciato bianco, diffusori in metacrilato satinato o in vetro (Casper e Zero).
Versioni dimmerabili ed emergenza disponibili a catalogo.
Per alcuni modelli è possibile scegliere fino a quattro temperature di colore (2700, 3000, 4000 e 5000K).

Rahmenlose Einbauleuchten zur Installation in den Zwischendecken aus Gipskarton.
Die Produkte sind in mehrere Formen und Größe verfügbar.
Struktur aus weiß lackiertem Aluminium oder verzinktes Blech.
Diffusor aus satiniertem Methacrylat oder Glas (Casper und Zero).
Dimmbarkeit und Notbeleuchtung ist weiter im Katalog vorgestellt
Für einige Modelle kann man über vier verschiedene Lichtfarbe wählen (2700, 3000, 4000 e 5000K).

Trimless recessed fixtures for installation in plasterboard false ceiling.
Wide range of dimensions, shapes and light solutions.
Frame in white painted aluminum or zinc coated metal. Diffuser in methacrylate or glass (Casper and Zero).
Dimmable and emergency options available on catalogue.
Up to four possible light tones available for some of the models (2700, 3000, 4000 e 5000K).

Aparatos de iluminación sin marco para instalación en falsos techos de cartón yeso.
Productos disponibles en formas y tamaños diferentes.
Cuerpo en aluminio o metal galvanizado pintado blanco.
Difusor de metacrilato satinado o vidrio (Casper y Zero).
Variantes dimmer o luz de emergencia se presentan a catalogo.
Por unas versiones hasta 4 tonos de luz: (2700, 3000, 4000 e 5000K)

Appareils encastrables sans cadre pour installation dans faux plafonds en plaque de plâtre.
Sont disponibles dans différentes formes, dimensions et typologie de lumière.
Corps en aluminium ou métal galvanisé verni blanc, diffuseurs en méthacrylate satiné ou en verre (Casper et Zero).
Versions dimmables et lumière de secours disponibles sur catalogue.
Pour certains modèles on peut choisir entre quatre tonalités de lumière (2700, 3000, 4000 e 5000K).

Светильники без рамки, встраиваемые в подвесные потолки.
Широкая линейка размеров, форм и световых параметров.
Корпус окрашен в белый цвет или из оцинкованного металла. Рассеиватель из метакрилата или стекла (серии Casper и Zero).. Доступны опции диммирования и установки аварийного блока.
Для некоторых моделей доступны до четырех вариантов цветовой температуры (2700, 3000, 4000 e 5000K).

QUADRATO COB LED - MODULO POWER LED

design: U.T. EGOLUCE

QUADRATO 12V-230V

design: U.T. EGOLUCE

Architectural

Architectural



6628 + COB LED 0,80 kg



.01 9,8x9,8cm.

Source LED cod.	OPTIC degree	lm	LED color
0107/XW	124 140 160	6,2W 17,8V 350mA 740lm	2700K
0107/WW	124 140 160	6,2W 17,8V 350mA 785lm	3000K
0107/W	124 140 160	6,2W 17,8V 350mA 829lm	4000K
0107/CW	124 140 160	6,2W 17,8V 350mA 850lm	5000K
0108/XW	124 140 160	9,2W 18,4V 500mA 995lm	2700K
0108/WW	124 140 160	9,2W 18,4V 500mA 1056lm	3000K
0108/W	124 140 160	9,2W 18,4V 500mA 1115lm	4000K
0108/CW	124 140 160	9,2W 18,4V 500mA 1160lm	5000K
0108/WW/IP	38	9,2W 18,4V 500mA 1056lm	3000K
0108/W/IP	38	9,2W 18,4V 500mA 1115lm	4000K

6628 + POWER LED 0,80 kg



.01 9,8x9,8cm.

Source LED cod.	OPTIC degree	lm	LED color
0121	25°	3x3W 700mA 846lm	4000K
0123	25°	3x3W 700mA 804lm	3000K

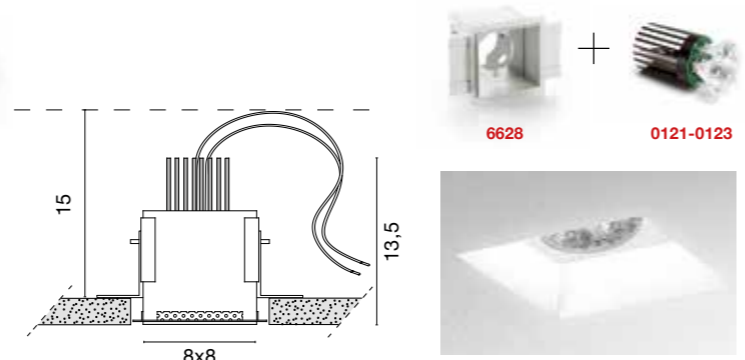
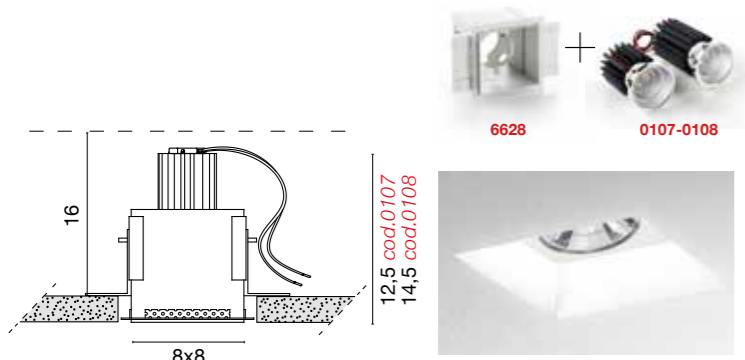

Source LED	Drivers	0125	0126	0147/COB	0128	0129	0129/DALI	0145	0145/DALI	0115/EM
		350mA	700mA	500mA	350mA	DIM	DIM DALI	DIM	DIM DALI	EMERGENCY
0107	1	NO	NO	NO	1-2	1-2	1-2	1-3	1-3	1
0108	NO	NO	NO	1-2	NO	1-2	1-2	1-3	1-3	1
0121	1-2	1-2	NO	NO	1-3	1-3	1-4	1-6	1-6	NO
0123	1-2	1-2	NO	NO	1-3	1-3	1-4	1-6	1-6	NO

6626 12V 0,6 kg

12V 50W GU5,3



.01 9,8x9,8cm.

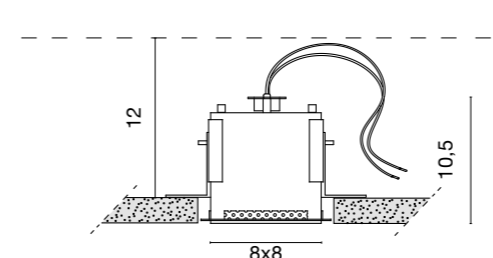

.01 9,8x9,8cm.

6627 230V 0,7 kg

50W GU10

7W GU10 LED (cod.0104/16)

7W GU10 LED (cod.0094/16)

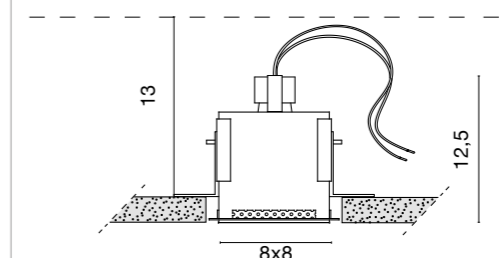

.01 9,8x9,8cm.

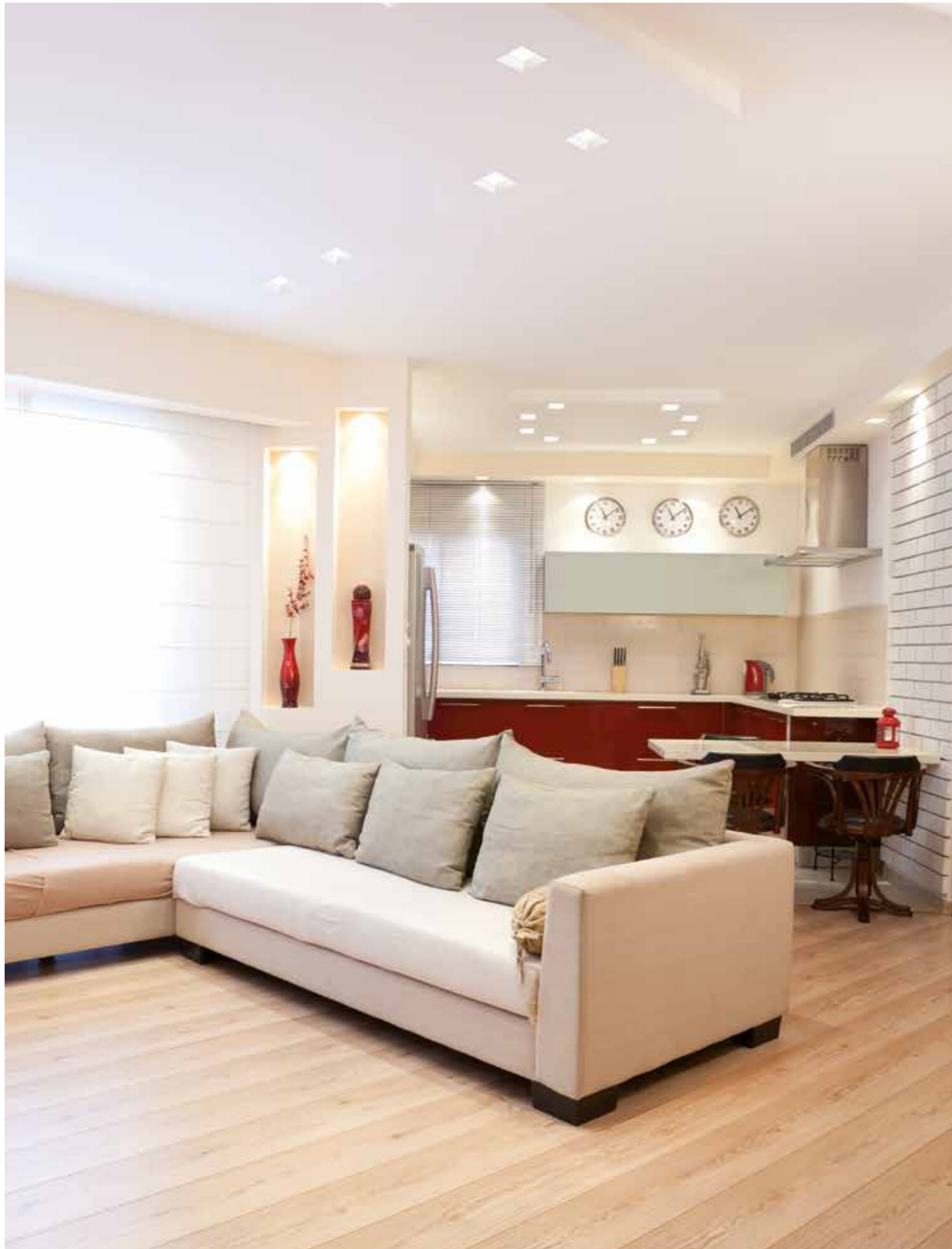

CASPER COB LED - MODULO POWER LED

design: U.T. EGOLUCE

CASPER 12V-230V

design: U.T. EGOLUCE

Architectural

Architectural



6622 + COB LED 0,80 kg



.57 10,5x10,5cm.

Source LED cod.	OPTIC degree	lm	LED color
0107/XW	124 140 160	6,2W 17,8V 350mA 740lm	2700K
0107/WW	124 140 160	6,2W 17,8V 350mA 785lm	3000K
0107/W	124 140 160	6,2W 17,8V 350mA 829lm	4000K
0107/CW	124 140 160	6,2W 17,8V 350mA 850lm	5000K
0108/XW	124 140 160	9,2W 18,4V 500mA 995lm	2700K
0108/WW	124 140 160	9,2W 18,4V 500mA 1056lm	3000K
0108/W	124 140 160	9,2W 18,4V 500mA 1115lm	4000K
0108/CW	124 140 160	9,2W 18,4V 500mA 1160lm	5000K
0108/WW/IP	38	9,2W 18,4V 500mA 1056lm	3000K
0108/W/IP	38	9,2W 18,4V 500mA 1115lm	4000K

6622 + POWER LED 0,80 kg



.57 10,5x10,5cm.

Source LED cod.	OPTIC degree	lm	LED color
0121	25°	3x3W 700mA 846lm	4000K
0123	25°	3x3W 700mA 804lm	3000K

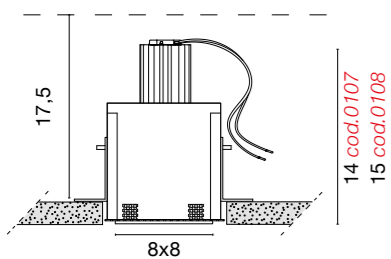

Source LED	Drivers	0125	0126	0147/COB	0128	0129	0129/DALI	0145	0145/DALI	0115/EM
		350mA	700mA	500mA	350mA	DIM	DIM DALI	DIM	DIM DALI	EMERGENCY
0107	1	NO	NO	NO	1-2	1-2	1-2	1-3	1-3	1
0108	NO	NO	NO	NO	1-2	1-2	1-2	1-3	1-3	1
0121	1-2	1-2	NO	NO	1-3	1-3	1-4	1-6	1-6	NO
0123	1-2	1-2	NO	NO	1-3	1-3	1-4	1-6	1-6	NO

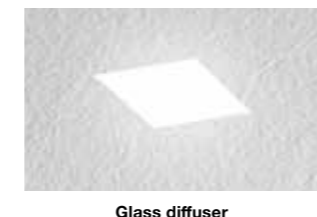
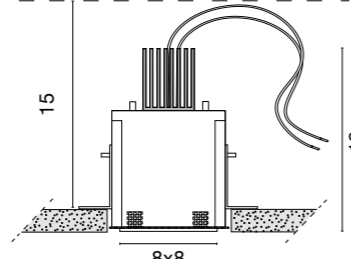
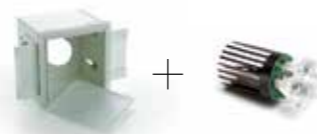

6620 12V 0,5 kg

12V 50W GU5,3



.57 10,5x10,5cm.



.57 10,5x10,5cm.

6621 230V 0,6 kg

50W GU10



7W GU10 LED (cod.0104/16)

7W GU10 LED (cod.0094/16)

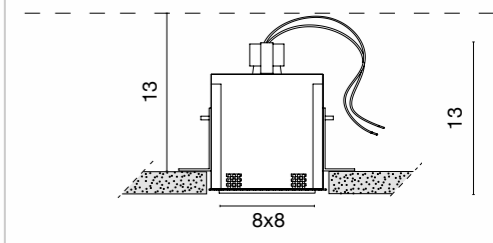
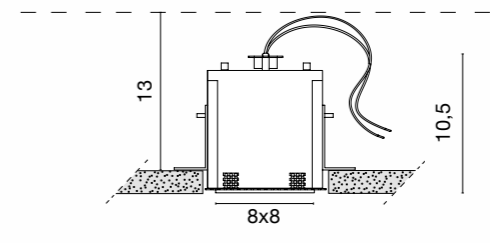

.57 10,5x10,5cm.

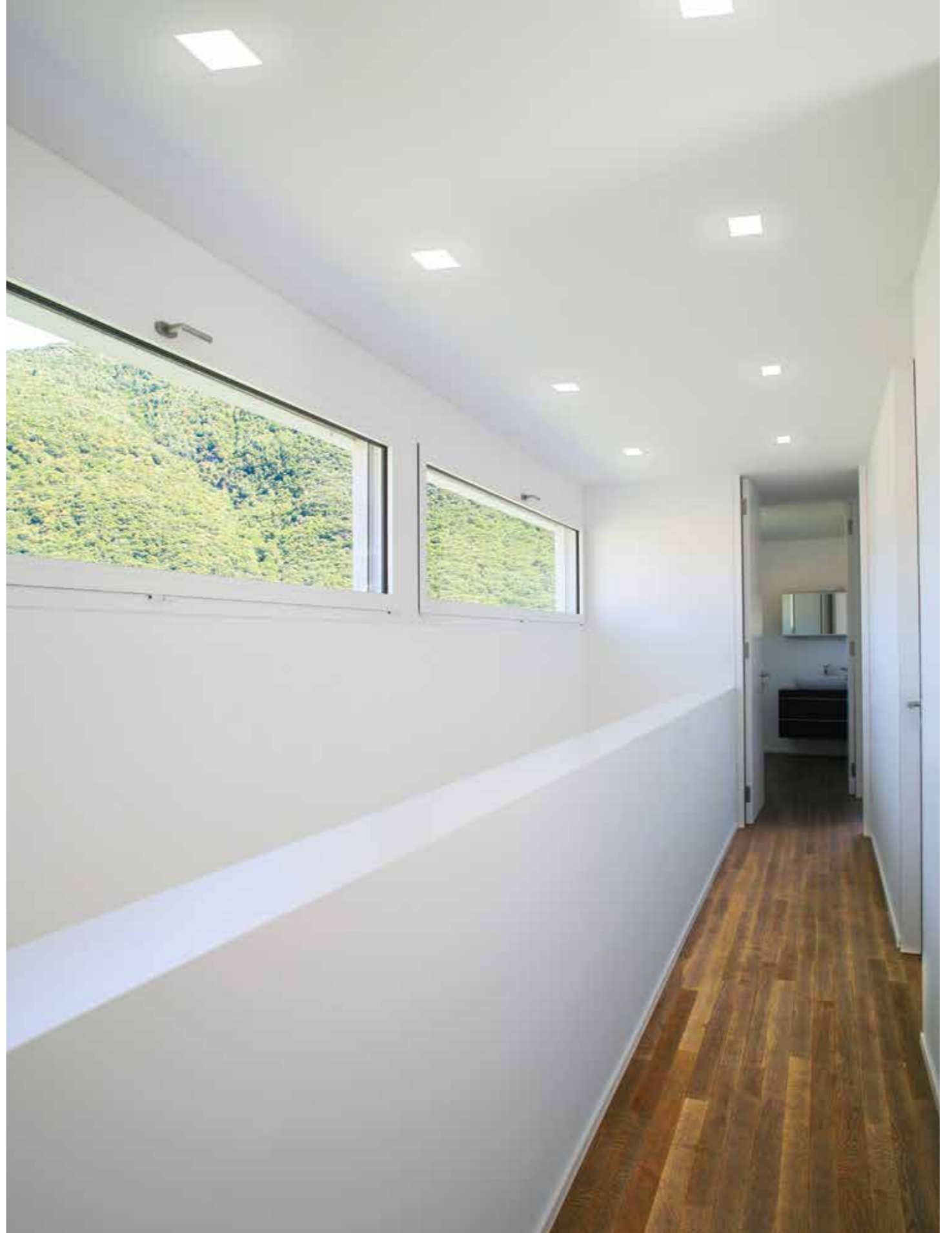

GHOST MINI

design: U.T. EGOLUCE

GHOST UP MINI

design: U.T. EGOLUCE

Architectural

Architectural



Methacrylate diffuser



Methacrylate diffuser

6604 ghost mini 2 kg

/WW Led 10,5W 1430lm 3000K

/W Led 10,5W 1430lm 4000K



6604 ghost mini DIMM DALI 2 kg

/WW Led 10,5W 1430lm 3000K

/W Led 10,5W 1430lm 4000K

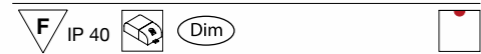

6604 ghost mini DIMM 1...10V 2 kg

/WW Led 10,5W 1430lm 3000K

/W Led 10,5W 1430lm 4000K

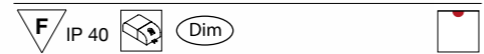

6629 ghost up mini 2,2 kg

/WW Led 10,5W 1430lm 3000K

/W Led 10,5W 1430lm 4000K



6629 ghost up mini DIMM DALI 2,2 kg

/WW Led 10,5W 1430lm 3000K

/W Led 10,5W 1430lm 4000K

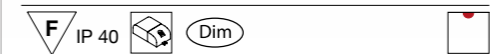

6629 ghost up mini DIMM 1...10V 2,2 kg

/WW Led 10,5W 1430lm 3000K

/W Led 10,5W 1430lm 4000K

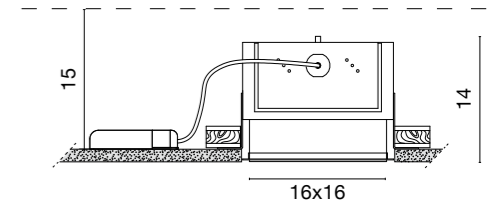
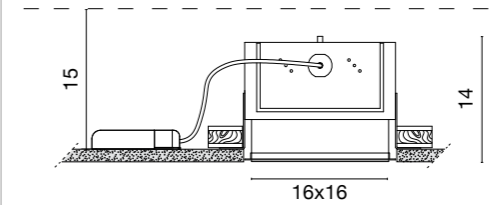
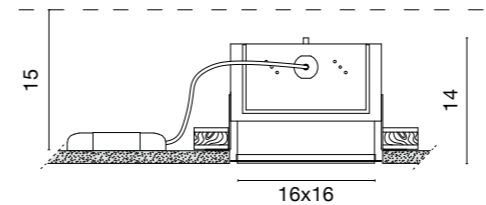
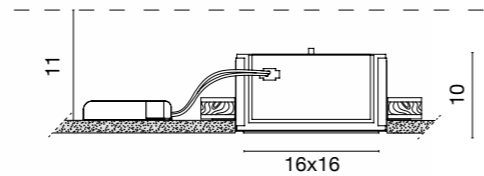
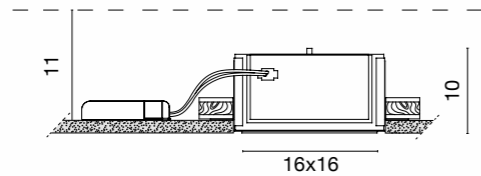
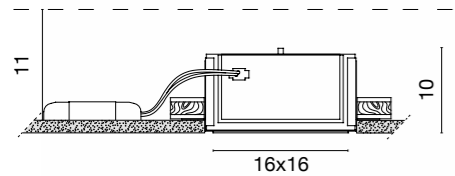
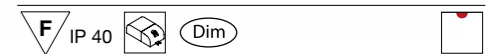

.01/W .01/WW 18,5x18,5cm.

.01/W/DALI .01/WW/DALI 18,5x18,5cm.

.01/W/DIM .01/WW/DIM 18,5x18,5cm.

.01/W .01/WW 18,5x18,5cm.

.01/W/DALI .01/WW/DALI 18,5x18,5cm.

.01/W/DIM .01/WW/DIM 18,5x18,5cm.

Drivers



0115/EM
Emergency Unit

Drivers



0115/EM
Emergency Unit



Methacrylate diffuser



Methacrylate diffuser

6608 ghost 1,9 kg

/ww Led 15,4W 1880lm 3000K

/w Led 15,4W 2050lm 4000K



6608 ghost DIMM DALI 1,9 kg

/ww Led 15,4W 1880lm 3000K

/w Led 15,4W 2050lm 4000K

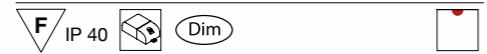

6608 ghost DIMM 1...10V 1,9 kg

/ww Led 15,4W 1880lm 3000K

/w Led 15,4W 2050lm 4000K

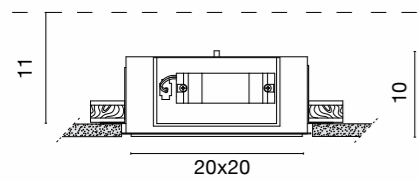
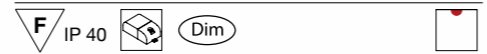

.01/W .01/WW 22,5x22,5cm.

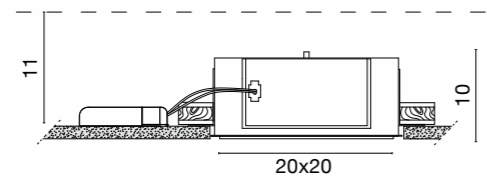

.01/W/DALI .01/WW/DALI 22,5x22,5cm.

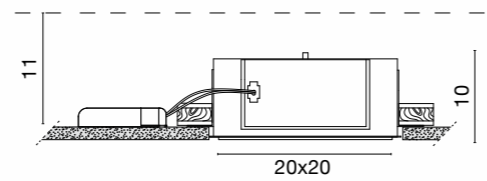

.01/W/DIM .01/WW/DIM 22,5x22,5cm.

Drivers



0115/EM
Emergency Unit

6643 ghost up 2,1 kg

/ww Led 15,4W 1880lm 3000K

/w Led 15,4W 2050lm 4000K

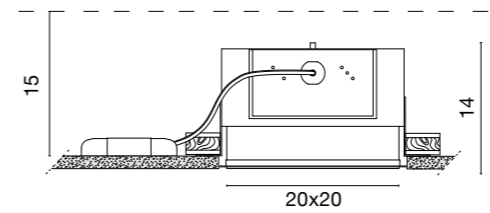

.01/W .01/WW 22,5x22,5cm.

6643 ghost up DIMM DALI 2,1 kg

/ww Led 15,4W 1880lm 3000K

/w Led 15,4W 2050lm 4000K

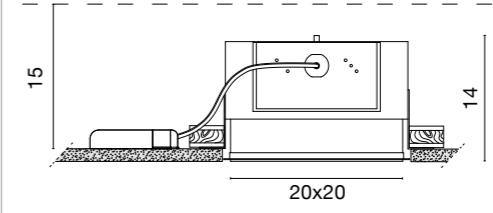
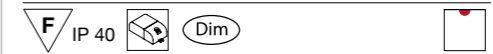

.01/W/DALI .01/WW/DALI 22,5x22,5cm.

6643 ghost up DIMM 1...10V 2,1 kg

/ww Led 15,4W 1880lm 3000K

/w Led 15,4W 2050lm 4000K

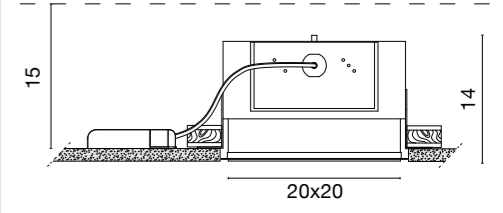
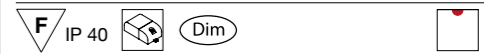

.01/W/DIM .01/WW/DIM 22,5x22,5cm.

Drivers



0115/EM
Emergency Unit

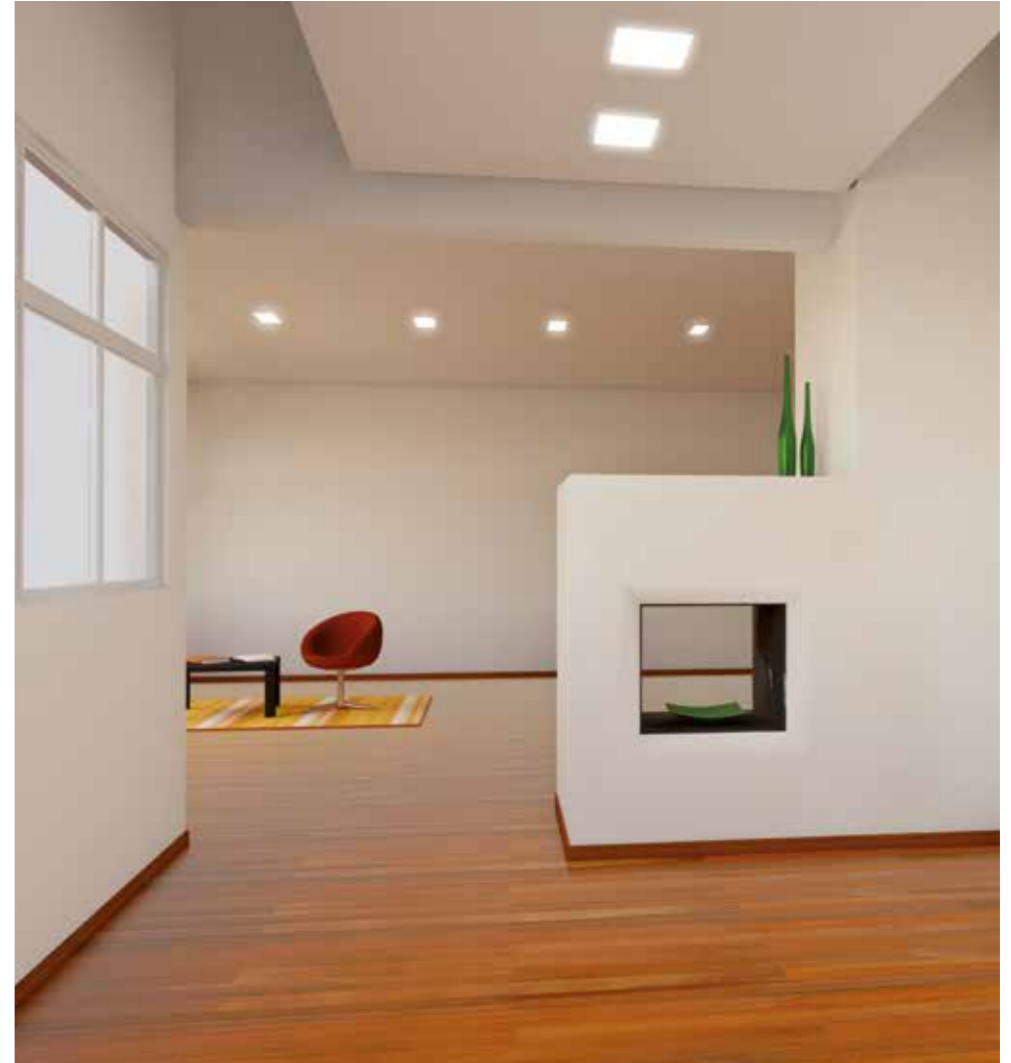



6607 ghost maxi 3,5 kg

WW Led 32,6W 3950lm 3000K

W Led 32,6W 4310lm 4000K

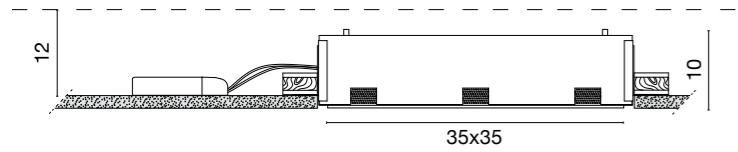

.01/W .01/WW 37x37cm.

Drivers



0115/EM
Emergency Unit



Methacrylate diffuser

6607 ghost maxi DIMM DALI 3,5 kg

WW Led 32,6W 3950lm 3000K

W Led 32,6W 4310lm 4000K

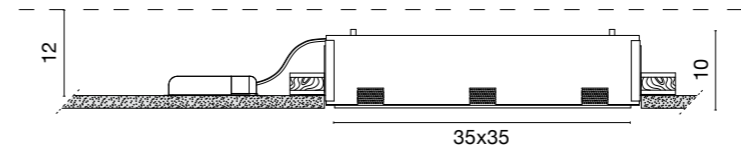

.01/W/DALI .01/WW/DALI 37x37cm.

Drivers



0115/EM
Emergency Unit

6607 ghost maxi DIMM 1...10V 3,5 kg

WW Led 32,6W 3950lm 3000K

W Led 32,6W 4310lm 4000K

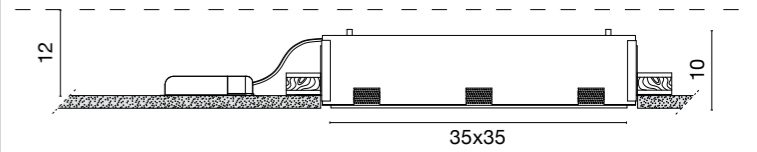

.01/W/DIM .01/WW/DIM 37x37cm.

Drivers



0115/EM
Emergency Unit



ROTONDO COB LED - MODULO POWER LED

design: U.T. EGOLUCE

ROTONDO 12V-230V

design: U.T. EGOLUCE



6415 + COB LED

0,21 kg



.01 9,2 cm.

Source LED cod.	OPTIC degree		lm	LED color
0107/XW	124 140 160	6,2W 17,8V 350mA	740lm	2700K
0107/WW	124 140 160	6,2W 17,8V 350mA	785lm	3000K
0107/W	124 140 160	6,2W 17,8V 350mA	829lm	4000K
0107/CW	124 140 160	6,2W 17,8V 350mA	850lm	5000K
0108/XW	124 140 160	9,2W 18,4V 500mA	995lm	2700K
0108/WW	124 140 160	9,2W 18,4V 500mA	1056lm	3000K
0108/W	124 140 160	9,2W 18,4V 500mA	1115lm	4000K
0108/CW	124 140 160	9,2W 18,4V 500mA	1160lm	5000K
0108/WW/IP	38	9,2W 18,4V 500mA	1056lm	3000K
0108/W/IP	38	9,2W 18,4V 500mA	1115lm	4000K

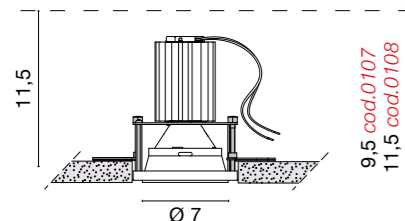

6415 + POWER LED

0,21 kg



.01 9,2 cm.

Source LED cod.	OPTIC degree		lm	LED color
0121	25°	3x3W 700mA	846lm	4000K
0123	25°	3x3W 700mA	804lm	3000K

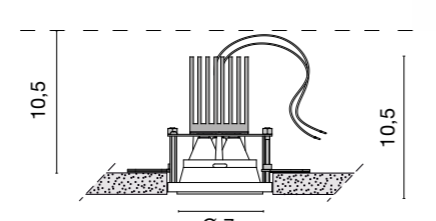

Source LED	Drivers	0126	0147/COB	0128	0129	0129/DALI	0145	0145/DALI	0115/EM
		350mA	500mA	350mA	DIM	DIM DALI	DIM	DIM DALI	EMERGENCY
0107	1	NO	NO	1-2	1-2	1-2	1-3	1-3	1
0108	NO	NO	1-2	NO	1-2	1-2	1-3	1-3	1
0121	1-2	1-2	NO	1-3	1-3	1-4	1-6	1-6	NO
0123	1-2	1-2	NO	1-3	1-3	1-4	1-6	1-6	NO

6415 12V

0,21 kg

12V 50W GU5,3

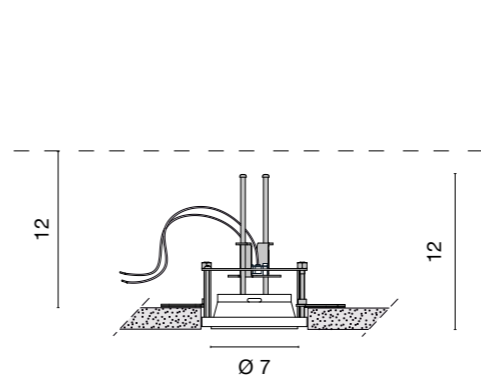
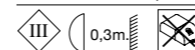

.01 9,2 cm.

6416 230V

0,27 kg

50W GU10

7W GU10 LED (cod.0104/16)

7W GU10 LED (cod.0094/16)

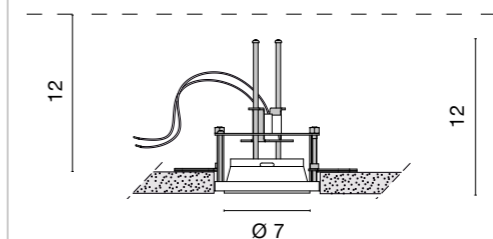

.01 9,2 cm.





ZERO COB LED - MODULO POWER LED

design: U.T. EGOLUCE

ZERO 12V-230V

design: U.T. EGOLUCE

Architectural

Architectural



6625 + COB LED 0,8 kg

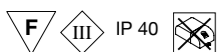

.57 Ø 11,4 cm.

Source LED cod.	OPTIC degree		lm	LED color
0107/XW	124 140 160	6,2W 17,8V 350mA	740lm	2700K
0107/WW	124 140 160	6,2W 17,8V 350mA	785lm	3000K
0107/W	124 140 160	6,2W 17,8V 350mA	829lm	4000K
0107/CW	124 140 160	6,2W 17,8V 350mA	850lm	5000K
0108/XW	124 140 160	9,2W 18,4V 500mA	995lm	2700K
0108/WW	124 140 160	9,2W 18,4V 500mA	1056lm	3000K
0108/W	124 140 160	9,2W 18,4V 500mA	1115lm	4000K
0108/CW	124 140 160	9,2W 18,4V 500mA	1160lm	5000K
0108/WW/IP	38	9,2W 18,4V 500mA	1056lm	3000K
0108/W/IP	38	9,2W 18,4V 500mA	1115lm	4000K

6625 + POWER LED 0,8 kg



.57 Ø 11,4 cm.

Source LED cod.	OPTIC degree		lm	LED color
0121	25°	3x3W 700mA	846lm	4000K
0123	25°	3x3W 700mA	804lm	3000K

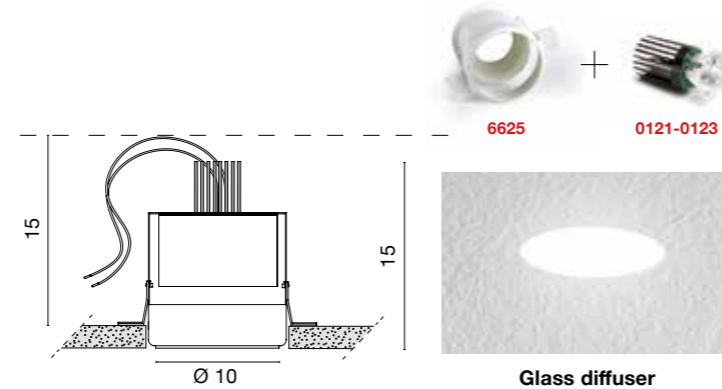
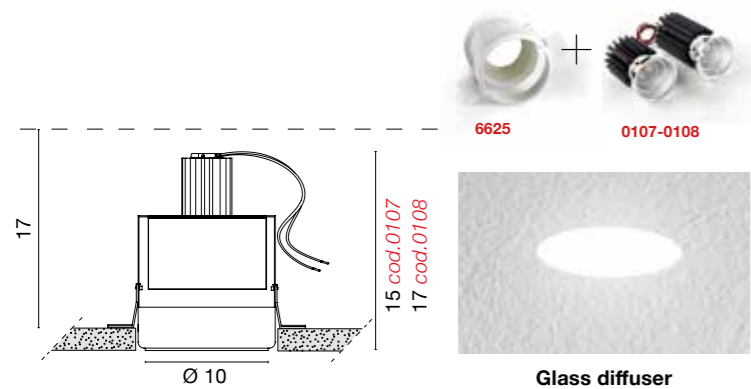

Source LED	Drivers	0126	0147/COB	0128	0129	0129/DALI	0145	0145/DALI	0115/EM
		700mA	500mA	350mA	DIM	DIM DALI	DIM	DIM DALI	EMERGENCY
0107	1	NO	NO	1-2	1-2	1-2	1-3	1-3	1
0108	NO	NO	1-2	NO	1-2	1-2	1-3	1-3	1
0121	1-2	1-2	NO	1-3	1-3	1-4	1-6	1-6	NO
0123	1-2	1-2	NO	1-3	1-3	1-4	1-6	1-6	NO

6623 12V 0,5 kg



12V 50W GU5,3

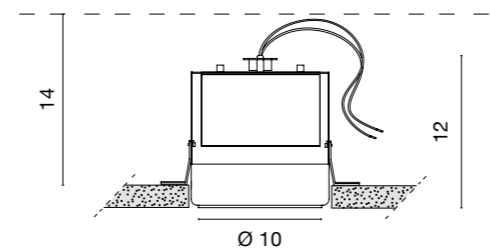

.57 Ø 11,4 cm.

6624 230V 0,6 kg

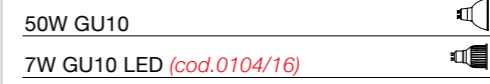

50W GU10

7W GU10 LED (cod.0104/16)

7W GU10 LED (cod.0094/16)

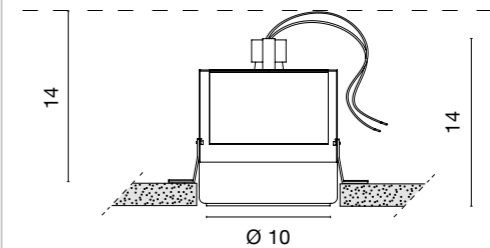

.57 Ø 11,4 cm.



Glass diffuser

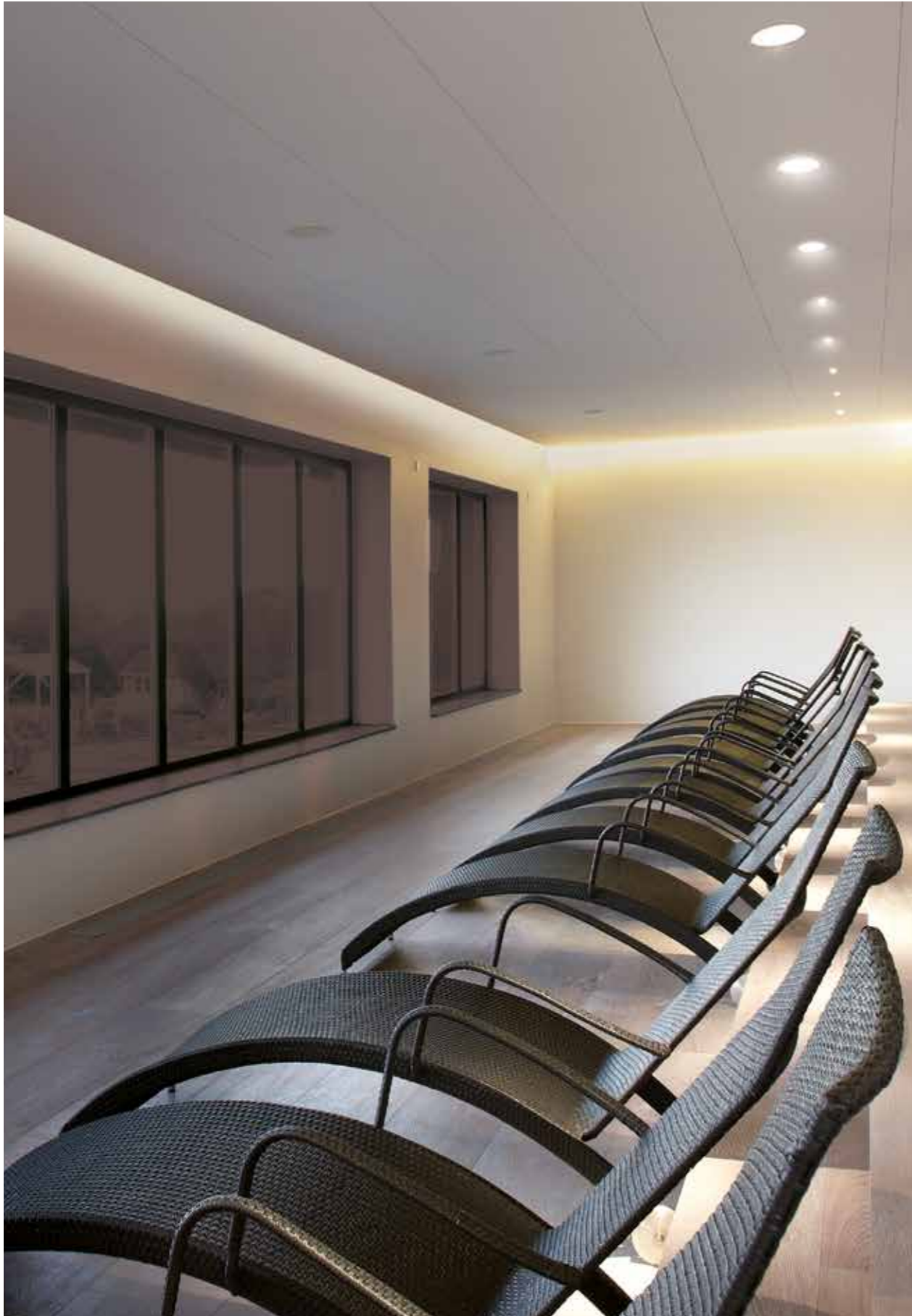

MIRAGE MINI

design: U.T. EGOLUCE

MIRAGE

design: U.T. EGOLUCE

Architectural



Methacrylate diffuser



Methacrylate diffuser

6605 mirage mini 1,9 kg

/WW Led 10,5W 1430lm 3000K

/W Led 10,5W 1430lm 4000K

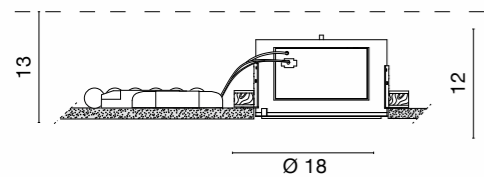

.01/W .01/WW 21,5 cm.

6605 mirage mini DIMM DALI 1,9 kg

/WW Led 10,5W 1430lm 3000K

/W Led 10,5W 1430lm 4000K

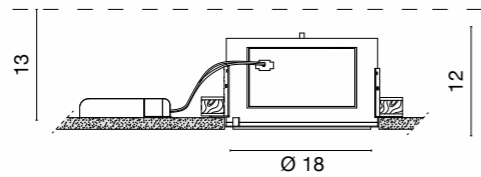
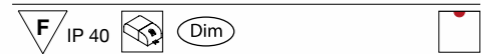

.01/W/DALI .01/WW/DALI 21,5 cm.

6605 mirage mini DIMM 1...10V 1,9 kg

/WW Led 10,5W 1430lm 3000K

/W Led 10,5W 1430lm 4000K

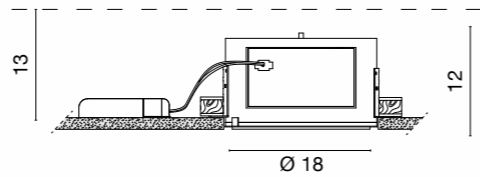
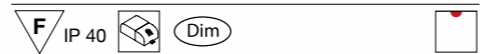

.01/W/DIM .01/WW/DIM 21,5 cm.

6609 mirage 1,9 kg

/WW Led 15,4W 1880lm 3000K

/W Led 15,4W 2050lm 4000K

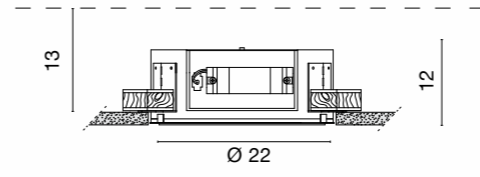

.01/W .01/WW 25,5 cm.

6609 mirage DIMM DALI 1,9 kg

/WW Led 15,4W 1880lm 3000K

/W Led 15,4W 2050lm 4000K

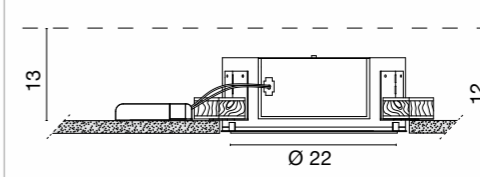

.01/W/DALI .01/WW/DALI 25,5 cm.

6609 mirage DIMM 1...10V 1,9 kg

/WW Led 15,4W 1880lm 3000K

/W Led 15,4W 2050lm 4000K

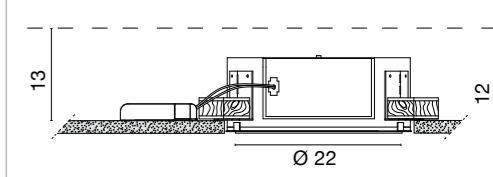

.01/W/DIM .01/WW/DIM 25,5 cm.

Drivers



0115/EM
Emergency Unit

Drivers



0115/EM
Emergency Unit



MIRAGE MAXI

design: U.T. EGOLUCE

MIRAGE MAXI

design: U.T. EGOLUCE

Architectural

Architectural



6654 mirage maxi 3,5 kg

/WW Led 32,6W 4310lm 3000K

/W Led 32,6W 3950lm 4000K

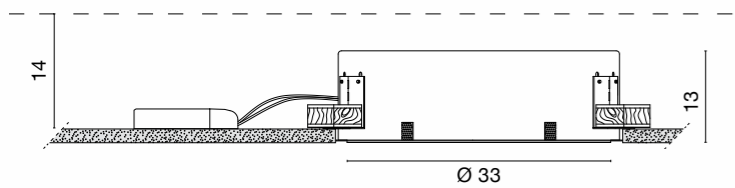

.01/W .01/WW ⌚ 36 cm.

Drivers



0115/EM
Emergency Unit



Methacrylate diffuser

6654 mirage maxi DIMM DALI 3,5 kg

/WW Led 32,6W 4310lm 3000K

/W Led 32,6W 3950lm 4000K

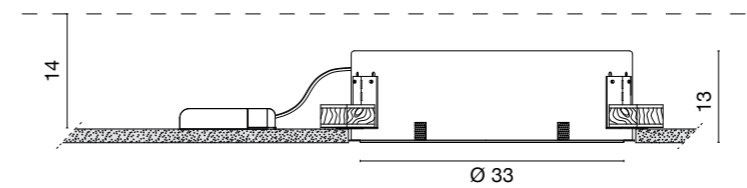

.01/W/DALI .01/WW/DALI ⌚ 36 cm.

Drivers



0115/EM
Emergency Unit

6654 mirage maxi DIMM 1...10V 3,5 kg

/WW Led 32,6W 4310lm 3000K

/W Led 32,6W 3950lm 4000K

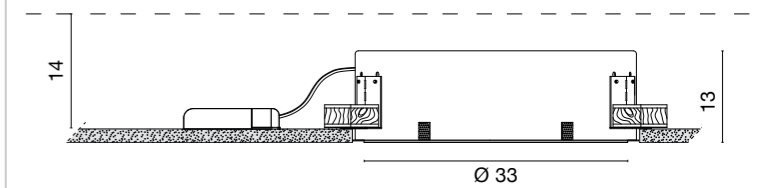

.01/W/DIM .01/WW/DIM ⌚ 36 cm.



SPOOK	p. 136
WANDA	p. 144
KEPÌ	p. 150
JAZZ	p. 154
ROC	p. 156
DRUM	p. 160
GEO	p. 162
VISION 1	p. 168
VISION 1 RGB	p. 169
VISION 3	p. 170
VISION 3 COB	p. 170
ZEPELIN	p. 174
ZEPELIN RGB	p. 176

ZEPELIN 25 PLUS	p. 178
ZEPELLIN MAXI COB	p. 180
ZEPELLIN MAXI	p. 182
ZEPELIN ORIENTABILE	p. 184
TRIS	p. 186
SOFT	p. 188
CERCHIO	p. 190
CERCHIO RGB	p. 192
STEP	p. 194
KROSS	p. 196
VISTA	p. 198
DRIVE	p. 200

OUTDOOR

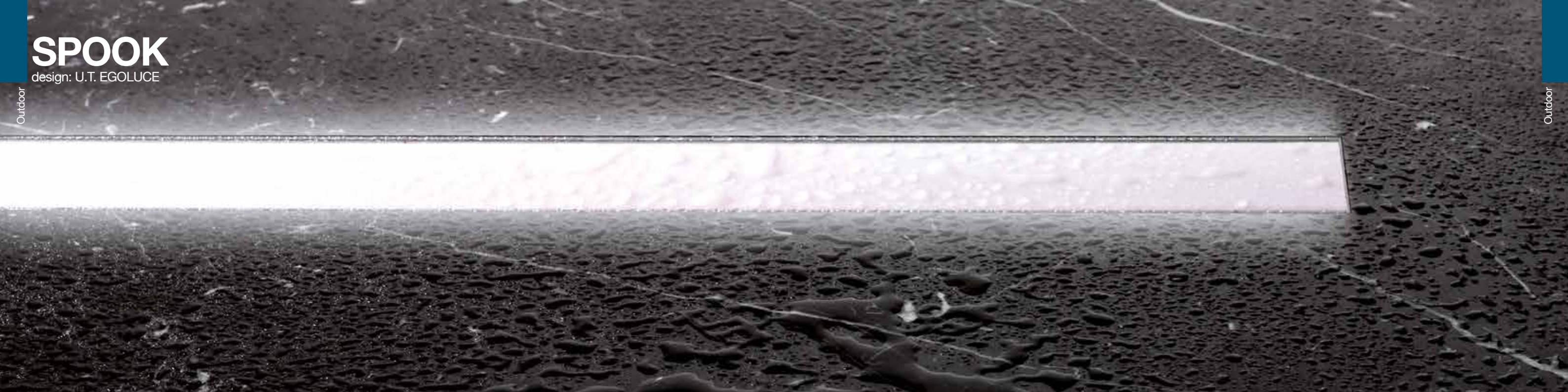

Linea luminosa LED calpestabile IP67 in metacrilato coestruso trasparente ed opalino. Casseforme modulari in alluminio anodizzato (anodizzazione rinforzata per esterni). Installazione a pavimento o parete con possibilità di comporre linee luminose continue.

Versione ETL disponibile a richiesta

LED linear walk-over IP67 in coextruded transparent and opal methacrylate. Modular anodized aluminium blind boxes (reinforced anodizing for outdoor). To be installed into floor or wall and possibility to compose endless light lines.

ETL version available upon request

Ligne lumineuse LED piétonnable IP67 en méthacrylate coextru transparent et opale. Boîtiers modulaires en aluminium anodisé (anodisation renforcée pour l'extérieur).

Installation au plancher ou cloison avec la possibilité d'obtenir des lignes lumineuses continues.

Version ETL disponible sur demande

Begehbarer LED Einbaulinie IP67, Struktur aus transparentem und opalisiertem fließgepresstem Methakrylat. Modularen Einbaugehäuse aus Aluminium (verstärktem Eloxierung für Außenbereich) für wand-oder Bodeneinsetzung. Montage als endlose Linearsystem möglich.

Linea luminosa LED pisable IP67 en metacrilato coestruso transparente y opal. Cajetin modular en aluminio anodizado (anodización reforzada para exterior). Instalación a suelo o pared y posibilidad de realizar líneas luminosas continuas.

Светодиодный встраиваемый в грунт профиль для пешеходных зон, степень защиты IP67, алюминий, прозрачный или матовый диффузор. Монтажный корпус из алюминия с усиленным анодированием для наружного использования. Для встраивания в пол или стену, можно составить бесконечную линию.



6417 0,8 kg

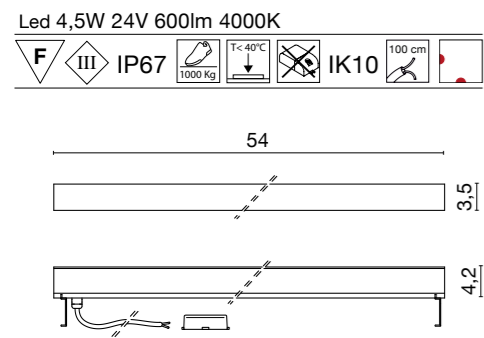

.01

6418 1,6 kg

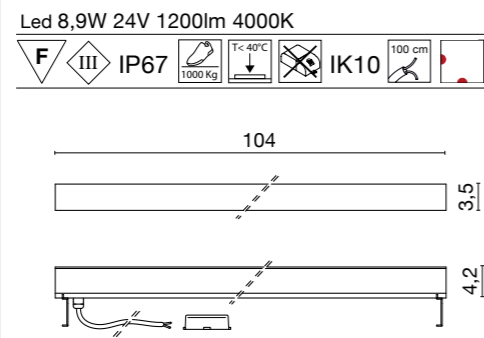

.01

6419 2,4 kg

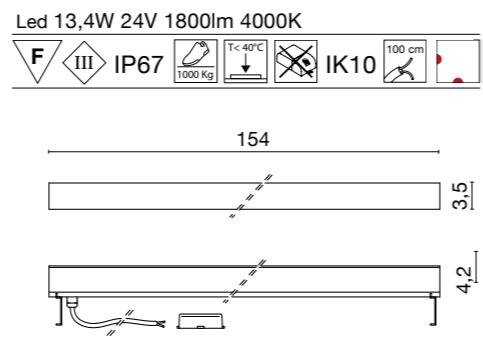

.01

Drivers



CUSTOM SIZE

Tabella lunghezze disponibili a richiesta.
Le misure si riferiscono alle lunghezze totali delle lampade.

Table of available lengths on request.
Measures are referred to complete fixtures including closing heads.

cm.	watt	3000K (WW)	lm	4000K (W)	lm
14	0,9W	A6417.01/14/WW	120	A6417.01/14/W	120
24	1,8W	A6417.01/24/WW	240	A6417.01/24/W	240
34	2,7W	A6417.01/34/WW	360	A6417.01/34/W	360
44	3,6W	A6417.01/44/WW	480	A6417.01/44/W	480
54	4,5W	A6417.01/54/WW	600	6417.01 *	600
64	5,3W	A6417.01/64/WW	720	A6417.01/64/W	720
74	6,2W	A6417.01/74/WW	840	A6417.01/74/W	840
84	7,1W	A6417.01/84/WW	960	A6417.01/84/W	960
94	8W	A6417.01/94/WW	1080	A6417.01/94/W	1080
104	8,9W	A6417.01/104/WW	1200	6418.01 *	1200
114	9,8W	A6417.01/114/WW	1320	A6417.01/114/W	1320
124	10,7W	A6417.01/124/WW	1440	A6417.01/124/W	1440
134	11,6W	A6417.01/134/WW	1560	A6417.01/134/W	1560
144	12,5W	A6417.01/144/WW	1680	A6417.01/144/W	1680
154	13,4W	A6417.01/154/WW	1800	6419.01 *	1800

* Articolo standard a catalogo - Standard catalogue item



Cassaforma di partenza con tappi ed elemento per manutenzione lampada
Starting recessed box with caps and element for lamp maintenance

0298

/54	55,1x4x9cm	0,9 kg
/104	105,1x4x9cm	1,7 kg
/154	155,1x4x9cm	2,6 kg



Cassaforma Recessed box

0299

/54	54,1x4x9cm	0,8 kg
/104	104,1x4x9cm	1,6 kg
/154	154,1x4x9cm	2,5 kg
/308	308,1x4x9cm	5,7 kg

I tappi di chiusura sono forniti con la cassaforma di partenza.
The end stoppers are included in the starting box.



2 staffe ancoraggio per cassaforma
2 anchor brackets for recessed box

0295



2 giunti per unione cassaforme
2 joints for recessed box

0293/S



2 tappi di chiusura per cassaforma
2 end stoppers for recessed box

0301

SPOOK

design: U.T. EGOLUCE

Outdoor

- 6417.01** cm.54
- 6418.01** cm.104
- 6419.01** cm.154
- A6417.01** cm.14 ... cm 144

Codifiche sistema Spook. Spook system codes

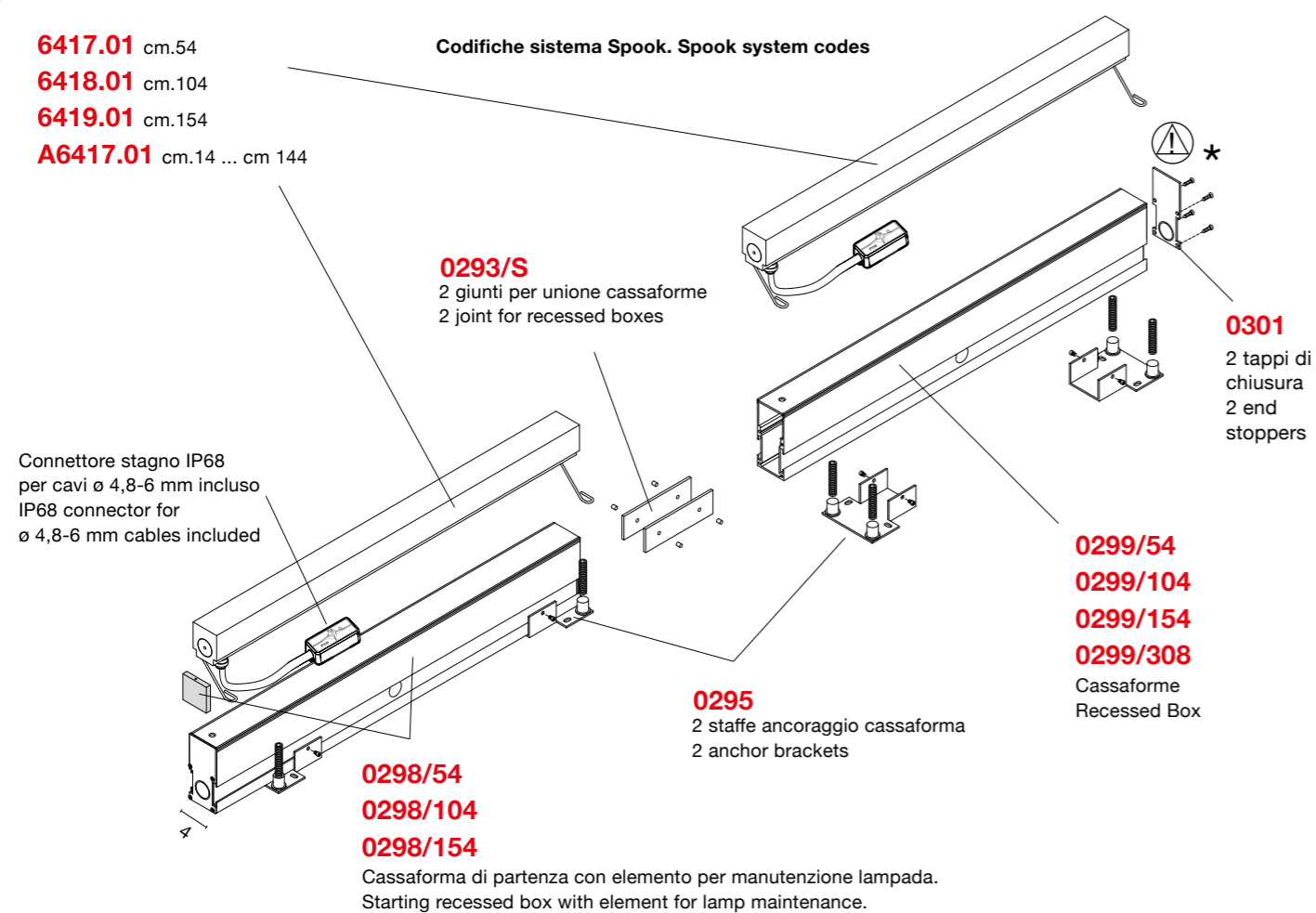

*Il tappo di chiusura è fornito con la cassaforma di partenza. The end stopper is included in the starting box.



Outdoor

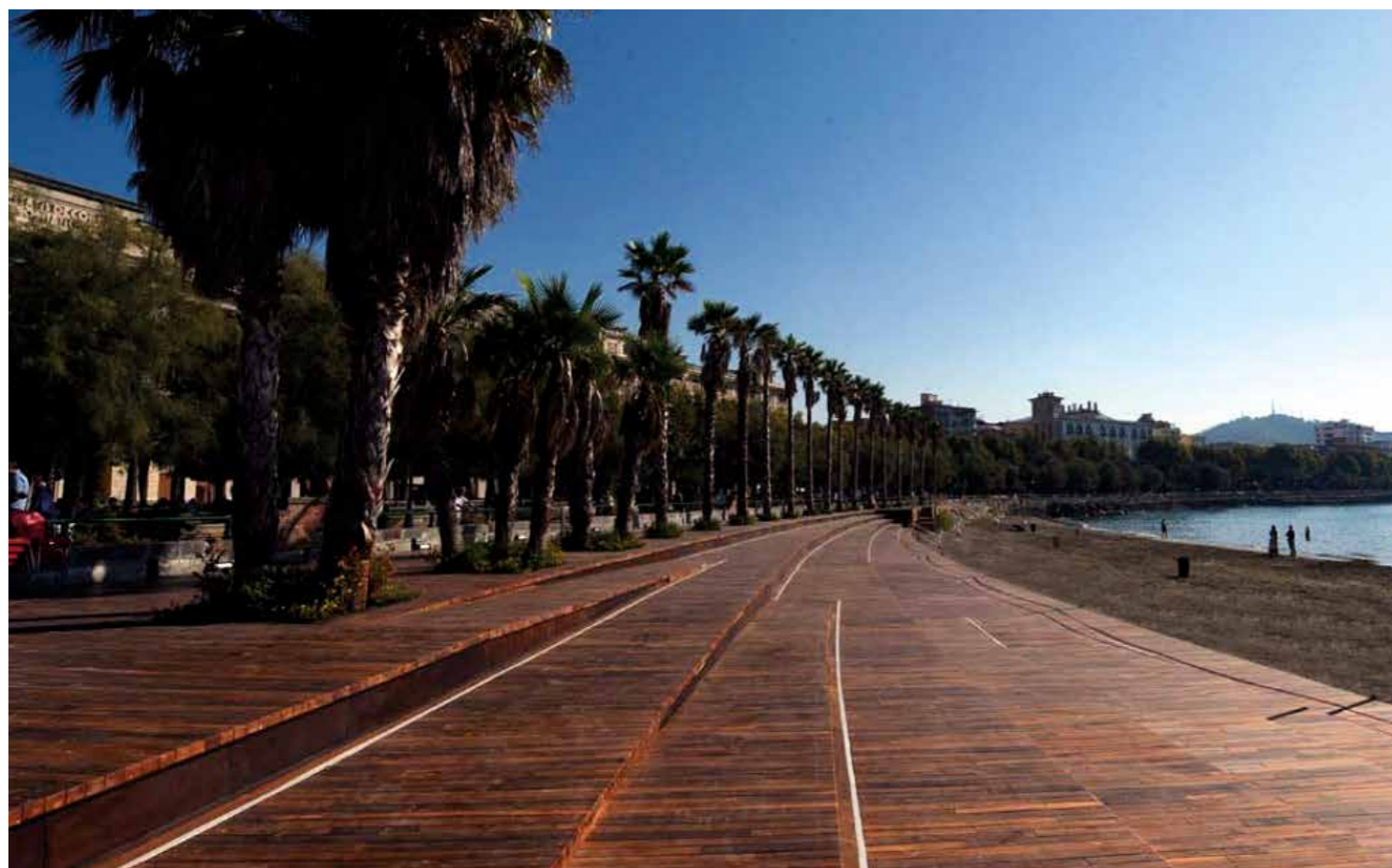





Barra luminosa orientabile a LED IP67 in metacrilato trasparente coestruso anti-UV e terminali in acciaio inox AISI 316L .

Cavo in neoprene da 100 cm. Applicazione a parete o a soffitto. Disponibile in diverse lunghezze fino a 3 metri. (pg. 148)

Versione ETL disponibile a richiesta

Adjustable LED profile IP67 in coextruded anti-UV transparent methacrylate and AISI 316L stainless steel terminals.

Neoprene cable 100 cm. Wall or ceiling installation possible. Available in different lengths up to 3 meters. (pg. 148)

ETL version available upon request

Barre lumineuse orientable à LED IP67 en méthacrylate transparent coextru anti-UV et terminales en acier inox AISI 316L . Câble en néoprène 100 cm.

Installable en applique ou au plafond. Disponibles en plusieurs longueurs jusqu'à 3 mètres. (pg. 148)

Version ETL disponible sur demande

Verstellbare Linear LED System IP67 aus transparentem fließgepresstem Methakrylat mit UV schutz und Endteile aus Edelstahl AISI316L.

Inkl. Neoprene Stromkabel 100 cm.

Zur Montage als Wand oder Deckenleuchte ist in verschiedene Länge bis Max. 3 Meter verfügbar. (pg. 148)

Barra luminosa orientable a LED IP67 en metacrilato claro coextruso anti-UV y terminales de acero inox AISI 316L.

Cable de neopreno 100 cm. Para montaje a pared y techo es disponible en varias larguras hasta 3 metros. (pg. 148)

Поворотный профиль со степенью защиты IP 67 из прозрачного метакрилата без УФ, концевые детали из нержавеющей стали. Кабель из неопрена 100 см. Для стены или потолка. В разных размерах до 3 метров длиной. (pg. 148)



4536 0,5 kg

Led 7,2W 24V 850lm 4000K

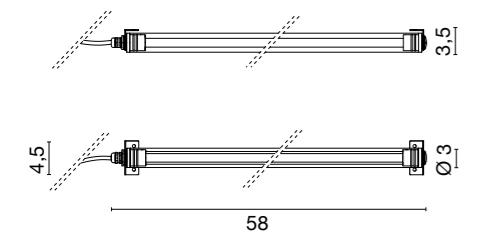

.33

4537 1kg

Led 15,8W 24V 1870lm 4000K

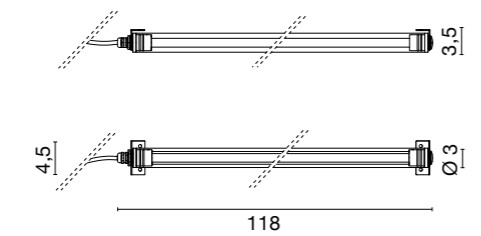

.33



4538 0,5 kg

Led 7,2W 24V

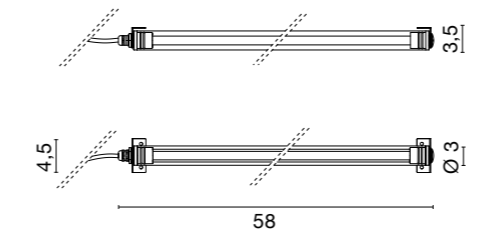

.33

4539 1 kg

Led 15,8W 24V

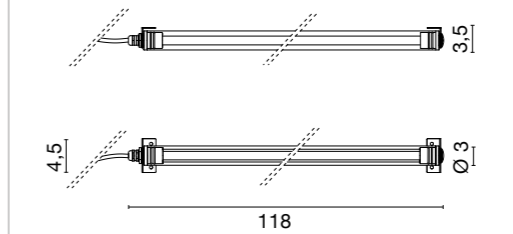

.33



Drivers



Accessories



Drivers



CUSTOM SIZE

Tabella lunghezze disponibili. Le misure si riferiscono alle lunghezze totali delle lampade.
Table of available lengths. Measures are referred to complete fixtures including closing heads.

cm.	watt	2700K (XW)	lm	3000K (WW)	lm	4000K (W)	lm	RGB
18	1,4W	A4536.33/18/XW	150	A4536.33/18/WW	160	A4536.33/18/W	170	A4536.33/18RGB
28	2,9W	A4536.33/28/XW	300	A4536.33/28/WW	320	A4536.33/28/W	340	A4536.33/28RGB
38	4,3W	A4536.33/38/XW	450	A4536.33/38/WW	480	A4536.33/38/W	510	A4536.33/38RGB
48	5,8W	A4536.33/48/XW	600	A4536.33/48/WW	640	A4536.33/48/W	680	A4536.33/48RGB
58	7,2W	A4536.33/58/XW	750	A4536.33/58/WW	800	4536.33 *	850	4538.33 *
68	8,6W	A4536.33/68/XW	900	A4536.33/68/WW	960	A4536.33/68/W	1020	A4536.33/68RGB
78	10,8W	A4536.33/78/XW	1050	A4536.33/78/WW	1120	A4536.33/78/W	1190	A4536.33/78RGB
88	11,5W	A4536.33/88/XW	1200	A4536.33/88/WW	1280	A4536.33/88/W	1360	A4536.33/88RGB
98	13W	A4536.33/98/XW	1350	A4536.33/98/WW	1440	A4536.33/98/W	1530	A4536.33/98RGB
108	14,4W	A4536.33/108/XW	1500	A4536.33/108/WW	1600	A4536.33/108/W	1700	A4536.33/108RGB
118	15,4W	A4536.33/118/XW	1650	A4536.33/118/WW	1760	4537.33 *	1870	4539.33 *
128	17,3W	A4536.33/128/XW	1800	A4536.33/128/WW	1920	A4536.33/128/W	2040	A4536.33/128RGB
138	18,7W	A4536.33/138/XW	1950	A4536.33/138/WW	2080	A4536.33/138/W	2210	A4536.33/138RGB
148	20,1W	A4536.33/148/XW	2100	A4536.33/148/WW	2240	A4536.33/148/W	2380	A4536.33/148RGB
158	21,6W	A4536.33/158/XW	2250	A4536.33/158/WW	2400	A4536.33/158/W	2550	A4536.33/158RGB
168	23W	A4536.33/168/XW	2400	A4536.33/168/WW	2560	A4536.33/168/W	2750	A4536.33/168RGB
178	24,5W	A4536.33/178/XW	2550	A4536.33/178/WW	2720	A4536.33/178/W	2890	A4536.33/178RGB
188	25,9W	A4536.33/188/XW	2700	A4536.33/188/WW	2880	A4536.33/188/W	3060	A4536.33/188RGB
198	27,4W	A4536.33/198/XW	2850	A4536.33/198/WW	3040	A4536.33/198/W	3230	A4536.33/198RGB
208	28,8W	A4536.33/208/XW	3000	A4536.33/208/WW	3200	A4536.33/208/W	3400	A4536.33/208RGB
218	30,2W	A4536.33/218/XW	3150	A4536.33/218/WW	3360	A4536.33/218/W	3570	A4536.33/218RGB
228	31,7W	A4536.33/228/XW	3300	A4536.33/228/WW	3520	A4536.33/228/W	3740	A4536.33/228RGB
238	33,W	A4536.33/238/XW	3450	A4536.33/238/WW	3680	A4536.33/238/W	3910	A4536.33/238RGB
248	34,6W	A4536.33/248/XW	3600	A4536.33/248/WW	3840	A4536.33/248/W	4080	A4536.33/248RGB
258	36W	A4536.33/258/XW	3750	A4536.33/258/WW	4000	A4536.33/258/W	4250	A4536.33/258RGB
268	37,4W	A4536.33/268/XW	3900	A4536.33/268/WW	4160	A4536.33/268/W	4420	A4536.33/268RGB
278	38,9W	A4536.33/278/XW	4050	A4536.33/278/WW	4320	A4536.33/278/W	4590	A4536.33/278RGB
288	40,3W	A4536.33/288/XW	4200	A4536.33/288/WW	4480	A4536.33/288/W	4760	A4536.33/288RGB
298	41,8W	A4536.33/298/XW	4350	A4536.33/298/WW	4640	A4536.33/298/W	4930	A4536.33/298RGB

★ Articolo standard a catalogo - Standard catalogue item

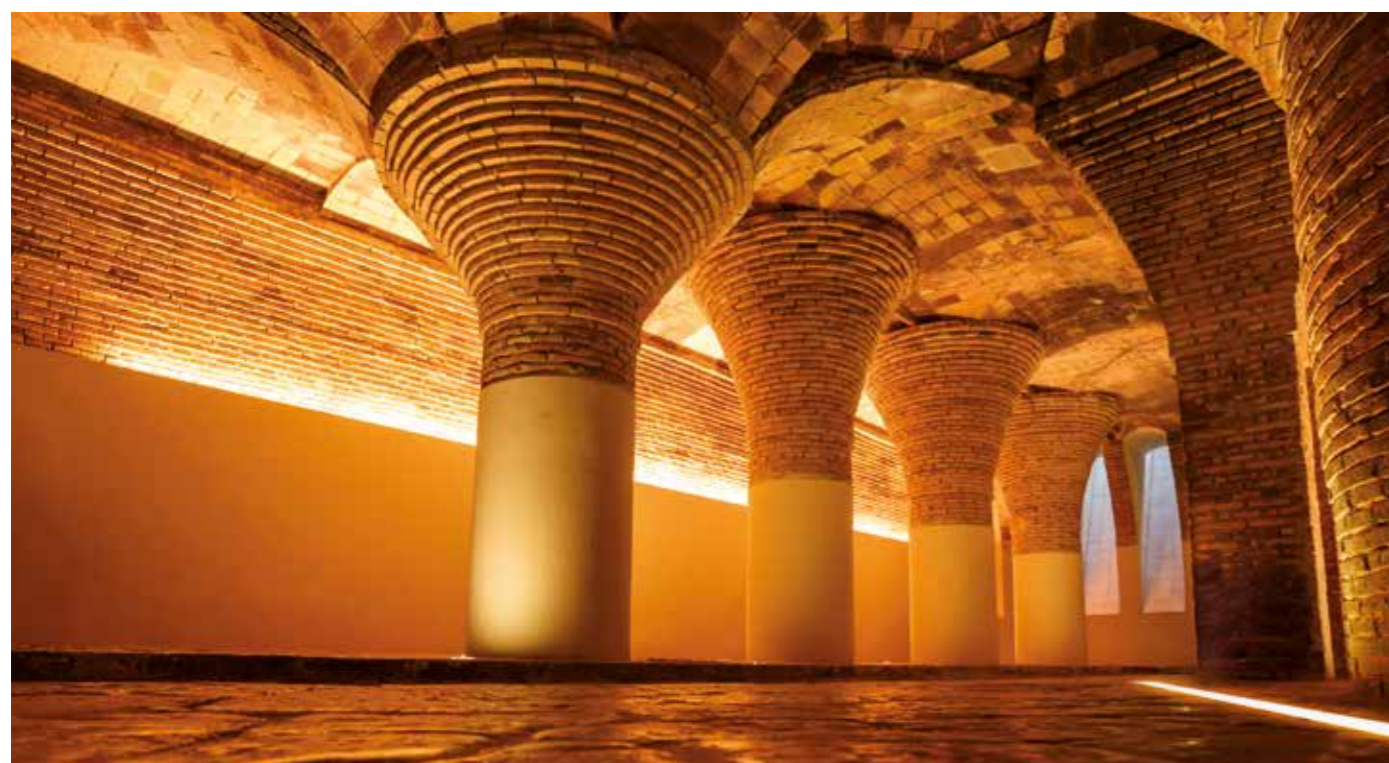
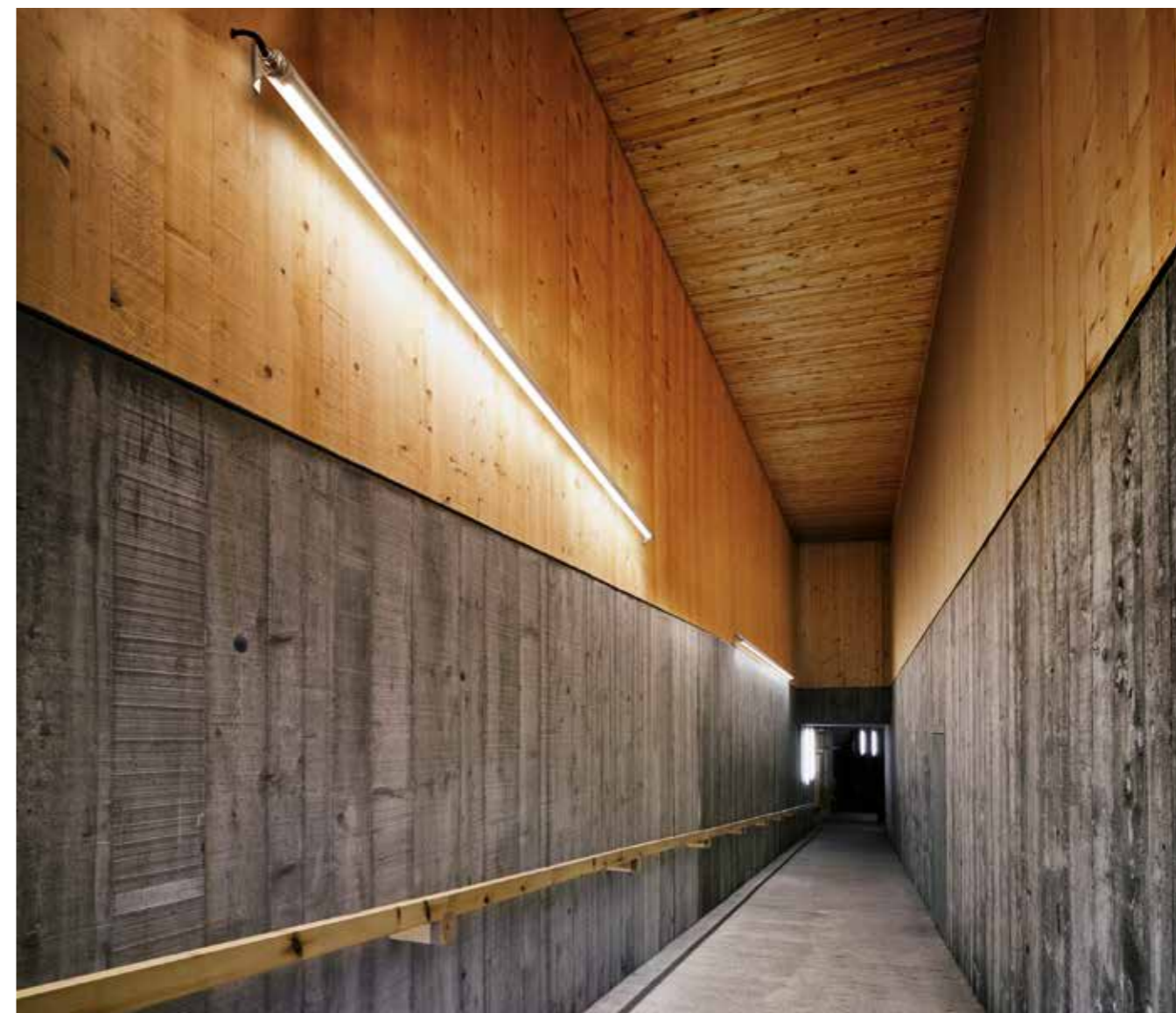



Lampada da esterno (IP 65) a luce asimmetrica. Struttura in alluminio anodizzato (finitura rinforzata per esterno) o verniciato Corten. Cavo in neoprene da 250 cm. ALIMENTATORE NON INCLUSO.

Versione ETL disponibile a richiesta

Outdoor lighting post (IP 65) for asymmetric light, stem in anodized aluminium (reinforced anodizing for outdoor) or painted corten finish. Neoprene cable 250 cm. CONVERTER NOT INCLUDED.

ETL version available upon request

Poteau (IP65) avec émission asymétrique, structure en aluminium en finition anodisée (anodisation renforcée pour extérieur) ou vernie corten. Câble en Néoprène 250 cm. PArt.0245 (à commander séparément).
CONVERTISSEUR PAS INCLUS.

Version ETL disponible sur demande

Außenleuchte IP65 für asymmetrisches Licht, Gestell aus Aluminium eloxiert (verstärktem Eloxierung für Außenbereich) oder corten lackiert. Neopren Stromkabel 250 cm. KONVERTER NICHT INKLUSIV

Aparato de iluminación IP65 por luz difusa, soporte en aluminio, acabado anodizado (anodización reforzada para exterior) o pintado corten. Con inclusión de bolas. Cable en Neopreno 250 cm.

CONVERTIDOR NO INCLUIDO

Уличный светильник рассеянного света с классом защиты IP65. Корпус из анодированного алюминия (усиленное анодирование для улицы). С кабелем из неопрена длиной 250 см. БЕЗ КОНВЕРТЕРА.



3502 1,6 kg

Led 7W 18,8V 350mA CRI>80 600lm 4000K

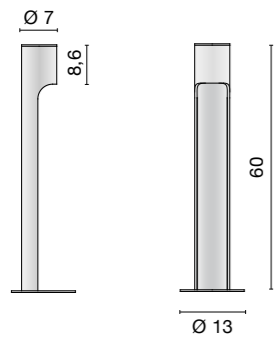

.03 .34

Accessories



0246
Box + Plate



0243
Connettore stagno
IP Connector

Drivers



0125 350 mA
(1 Kepi)



0031/IP 350 mA
(1 Kepi)



0128 350 mA
(1-2 Kepi)



JAZZ

design: F. Rienzi

Outdoor



Lampada da esterno IP65 per installazione a soffitto/parete.

Corpo in alluminio anodizzato e verniciato bianco, diffusore in metacrilato satinato.

Riflettore in alluminio anodizzato verniciato bianco o nero oppure in rame lucidato protetto da verniciatura trasparente zapon.

Modulo LED da 670Lm a tensione di rete 220/240V di ultima generazione.

Ceiling/wall lamp IP65 for outdoor use.

Anodized aluminum body painted in white, satin methacrylate diffuser.

Anodized aluminum reflector white or black finish, or polished copper protected with zapon clear varnish.

Latest generation LED 670Lm plate for main supply 220-240V.

Lampe plafond/mur IP65 pour usage extérieur.

Corps en aluminium anodisé verni blanc et diffuseur en méthacrylate satiné.

Réflecteur en aluminium anodisé verni blanc ou noir, ou en cuivre dépoli protégé avec vernis transparent zapon.

Module LED 670Lm LED à tension du réseau 220-240V de nouvelle génération.

Wand-/Deckenleuchte für Außenbereich mit Schutzart IP65.

Gehäuse aus eloxiertem Aluminium weiß und Diffusor aus satiniertem Methacrylat.

Reflektor aus eloxiertem Aluminium Ausführung weiß oder schwarz, oder aus Kupfer poliert mit farblose zapon-Lack geschützt.

670Lm neuester Generation LED-Modul für Netzspannung 220-240V.

Lámpara de techo/pared IP65 para exteriores. Cuerpo de aluminio anodizado pintado blanco y pantalla de metacrilato satinado.

Reflector de aluminio anodizado pintado blanco o negro, o en cobre pulido protegido con barniz zapon incoloro.

Modulo LED 670Lm de última generación para tensión de red 220-240V.

Потолочный/настенный светильник для наружного использования IP65.

Корпус из анодированного алюминия окрашен в белый цвет.

Рассеиватель из сатинированного метакрилата. Отражатель из анодированного алюминия, окрашен в белый или черный цвет, или из полированной меди, покрытый защитным прозрачным лаком.

Светодиодный модуль последнего поколения со световым потоком 670лм, подключается напрямую в сеть 220в.

5538

0,6 kg

Led 8,7W 220-240V 670lm 3000K

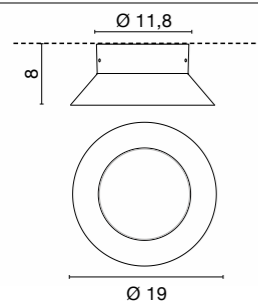
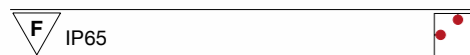

.01/WW .02/WW .38/WW



Outdoor



Lampada da esterno IP65 per installazione a soffitto/parete. Corpo in alluminio anodizzato e verniciato bianco, schermo in metacrilato opalino. Diffusore in vetro pressato extra-chiaro lucidato. Modulo LED da 670Lm a tensione di rete 220/240V di ultima generazione.

Lampe plafond/mur IP65 pour usage extérieur. Corps en aluminium anodisé et verni blanc, écran de méthacrylate opalin. Diffuseur en verre pressé poli extra-clair. Module LED 670Lm LED à tension du réseau 220-240V de nouvelle génération.

Lámpara de techo/pared IP65 para exteriores. Cuerpo de aluminio anodizado y pintado blanco. Pantalla de metacrilato opalino y difusor de cristal prensado extra claro pulido. La lámpara está equipada con módulo LED 670Lm de última generación para tensión de red 220-240V.

Ceiling/wall lamp IP65 for outdoor use. Aluminum body is anodized and white painted, opal methacrylate screen. Polished pressed extra-clear glass diffuser. The lamp is fitted with 670Lm latest generation LED plate for main supply 220-240V.

Wand- und Deckenleuchte für Außenbereiche mit Schutzart IP65. Gehäuse aus eloxiertem und weiß lackiertem Aluminium, Schirm aus opalisiertem Acrylglas. Diffusor aus Pressglas, extraklar und poliert. Die Leuchte ist ausgestattet mit einem 670Lm LED-Modul neuester Generation für Netzspannung 220-240V.

Потолочный/настенный светильник для наружного использования IP65. Анодированный алюминий, окрашен в белый цвет. Рассеиватель из матового метакрилата. Диффузор из сверхяркого стекла. Светодиод на плате последнего поколения 670лм для подключения в сеть 220в.

5539 1,5 kg

Led 8,7W 220-240V 670lm 3000K

F IP65

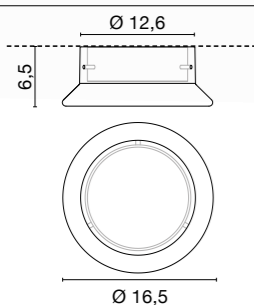

.01/WW



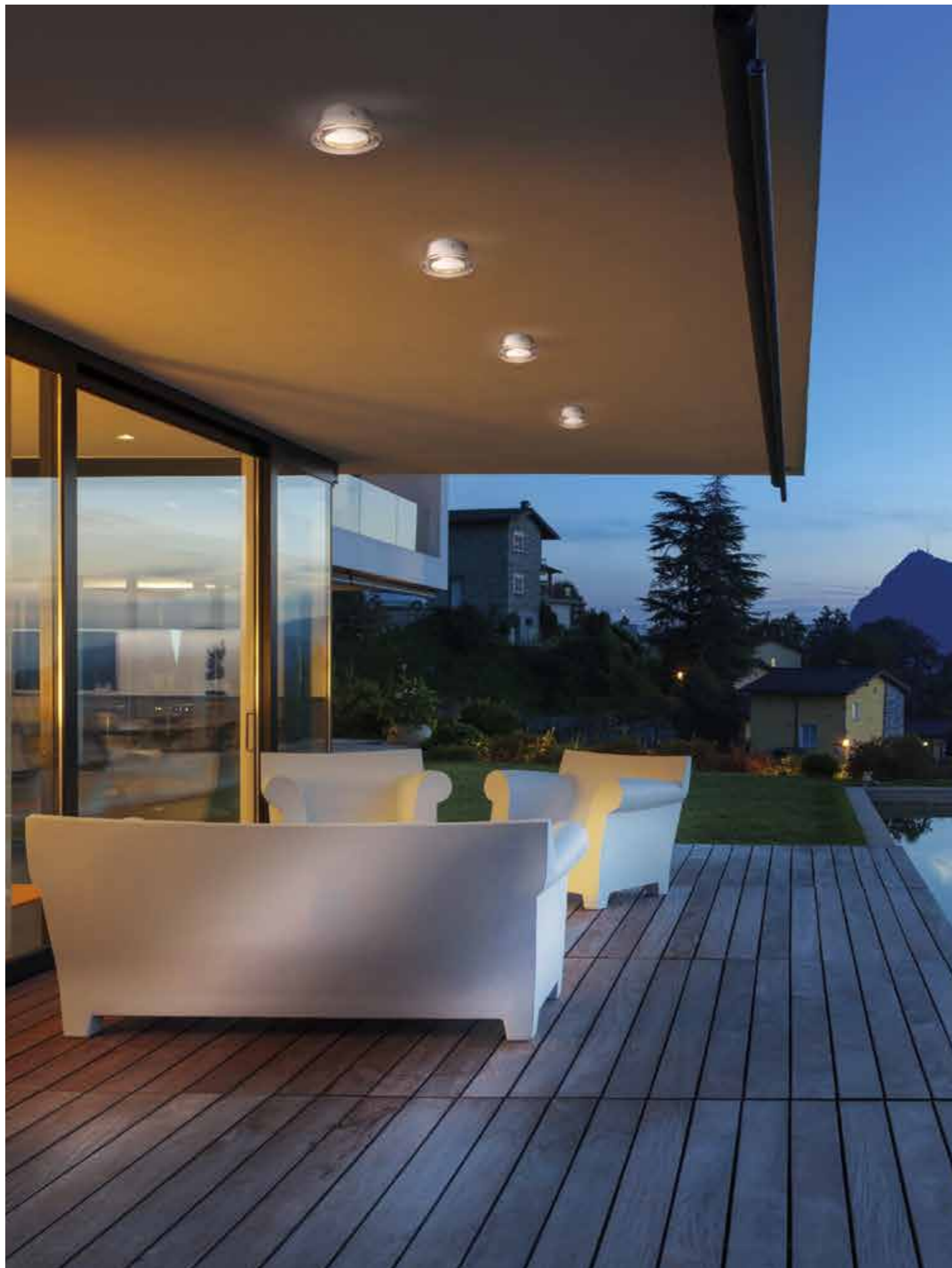

DRUM

design: U.T. EGOLUCE

Outdoor



Lampada LED da plafone o parete IP65 in alluminio anodizzato (anodizzazione rinforzata per esterni) o verniciato bianco e diffusore in metacrilato. Modulo LED 10W 220-240V.

Wall or ceiling LED lamp IP 65, aluminium body in anodized (reinforced anodizing for outdoor) or white painted finish. Metachrilate diffuser. 10W LED module 220-240V.

Applique ou plafonnier LED IP 65, corps en aluminium anodisé (anodisation renforcée pour l'extérieur) ou verni blanc et diffuseur en metachrilate satiné. Module LED 10W 220-240V.

Wand- oder Deckenleuchte LED IP65, Körper aus Aluminium eloxiert (verstärktem Eloxierung für Außenbereich) oder weiß lackiert. Metakrilat Diffusor matt. LED Modul 10W 220-240V.

Lampara LED de pared y de techo IP65, estructura en aluminio anodizado (anodisacion reforzada para exterior) o pintada blanca y difusor en metacrilato satinado. Modulo LED 10W 220-240V.

Потолочный или настенный светильник со степенью защиты IP65 из алюминия с усиленным анодированием для наружного использования или окрашенный в белый цвет. Диффузор из матового метакрилата. Светодиодный модуль 10 ватт для подключения в сеть 220-240в.

5520

1,1 kg

Led 10W 220-240V 850lm 3000K

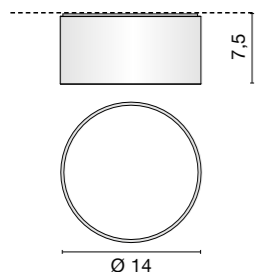

.01WW .45WW





Proiettori LED IP65 per luce radente mono o bitemissione, fascio luminoso di 17°/35°, corpo in alluminio anodizzato (anodizzazione rinforzata per esterni).
ALIMENTATORE NON INCLUSO.

IP65 LED projectors for grazing light with double or single side emission, 17°/35° beam, body in anodized aluminium (reinforced anodizing for outdoor).
CONVERTER NOT INCLUDED.

Projecteurs LED IP65 pour lumière rasante avec simple ou double émission. Faisceau de 17°/35°, structure en aluminium anodisé (anodisation renforcée pour l'extérieur).
CONVERTISSEUR PAS INCLUS.

LED Strahler IP65 für streifende Licht, einseitigem oder zweiseitigem Strahlung. Abstrahlwinkel 17°/35°, Struktur aus Aluminium Eloxiert (verstärktem Eloxierung für Außenbereich).
KONVERTER NICHT INKLUSIV

Proyectors LED IP65 para luz rasante, simple o doble emision, haz de luz de 17°/35°, estructura en aluminio anodizado (anodisation reforzada para exterior).
CONVERTIDOR NO INCLUIDO

Светодиодные прожекторы IP65 для брейущего света с одним или двумя лучами 17°/35° градуса. Корпус из алюминия с усиленным анодированием для наружного использования.
БЕЗ КОНВЕРТЕРА.

GEO

design: U.T. EGOLUCE

Outdoor



4513 geo monoemissione 0,9 kg



.45

Source LED cod.	OPTIC degree	lm	LED color
/WW	/17 /35	1x4,5W 12,2V 350mA 400lm	3000K
/W	/17 /35	1x4,5W 12,2V 350mA 440lm	4000K

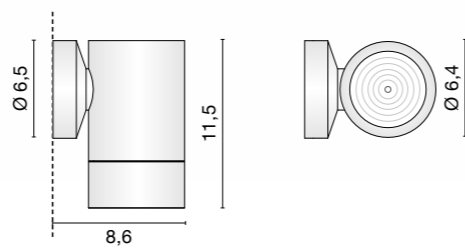

4514 geo biemissione 1,1 kg

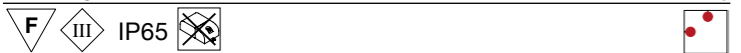

.45

Source LED cod.	OPTIC degree	lm	LED color
/WW	/17 /35	2x4,5W 24,4V 350mA 800lm	3000K
/W	/17 /35	2x4,5W 24,4V 350mA 880m	4000K

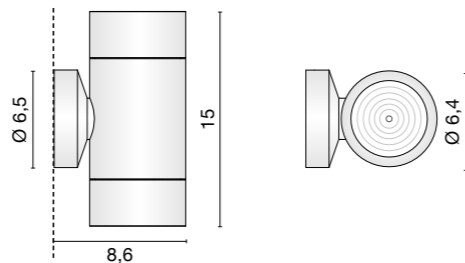

Drivers	0031/IP 350mA	0125 350mA	0128 350mA	0129 DIM	0129/DALI DIM DALI	0145 DIM	0145/DALI DIM DALI
4513	1-3	1	1-3	1-3	1-3	1-5	1-5
4514	1	NO	1	1	1	1-2	1-2





Serie di proiettori orientabili per esterno in alluminio anodizzato (finitura rinforzata per esterno) con staffa in acciaio INOX AISI 316L. Con cavo in neoprene. Predisposti per l'installazione a pavimento, a parete, a soffitto o temporanea su terreno.

Versione ETL disponibile a richiesta

Series of adjustable outdoor projectors in anodized aluminium (reinforced anodizing for outdoor) with bracket in stainless steel AISI 316L. Supplied with neoprene cable. To be installed on tile, pavements, wall, ceiling or temporary positioning on soft grounds.

ETL version available upon request

Serie de projecteurs orientables en aluminium anodisé (anodisation renforcée pour extérieur) avec fourche en acier inox AISI316L. Fourni avec câble en néoprène. Prévu pour installation fixe à mur, sur pavements, au plafond, ou pour positionnement temporaire sur terrain.

Version ETL disponible sur demande

Reihe von Schwenkbarer Lichtstrahler IP67 aus eloxiertem Aluminium (verstärktem Eloxierung für Außenbereich). Neopren Kabel. Versehen für Festmontage auf Wand oder Boden, oder Decken oder temporäre Positionierung auf Land.

Serie de Focos orientables IP67 en aluminio anodizado (anodización reforzada para exterior) con soporte en acero AISI 316L. Cable en neopreno. Previsto para instalación fija a pared, pavimentaciones, o techo y posicionamiento provisorio en suelo.

Серия поворотных прожекторов с классом защиты IP67. Корпус из анодированного алюминия (усиленное анодирование для улицы) с кронштейном из нержавеющей стали. С кабелем из неопрена длиной. Для установки на мостовую, на стену или временной установки на грунт.

VISION 1

design: U.T. EGOLUCE

VISION 1 RGB

design: U.T. EGOLUCE

Outdoor

Outdoor



4510	0,25 kg
WW Led max 2W 500mA 199lm 3000K	
W Led max 2W 500mA 209lm 4000K	

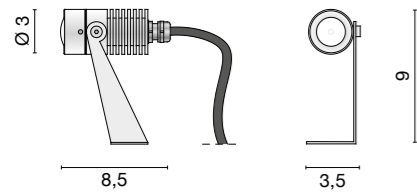

.45W .45WW

Accessories



Drivers



4554	0,25 kg
Led 3x250mA	

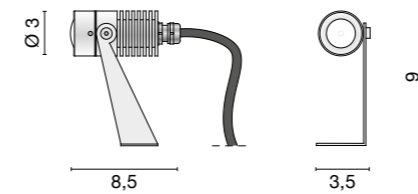

.45

Drivers



Accessories



VISION 3

design: U.T. EGOLUCE

Outdoor



4555 Vision 3 COB 0,21 kg



.45

Source LED cod.	OPTIC degree		lm	LED color
/WW	/25 /42	9,2W 18,4V 500mA	1056lm	3000K
/W	/25 /42	9,2W 18,4V 500mA	1115lm	4000K

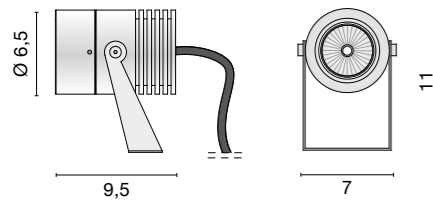

4511 Vision 3 0,7 kg



.45

Source LED cod.	OPTIC degree		lm	LED color
/WW	/10 /25 /40	3x2W 500mA	597lm	3000K
/W	/10 /25 /40	3x2W 500mA	627lm	4000K

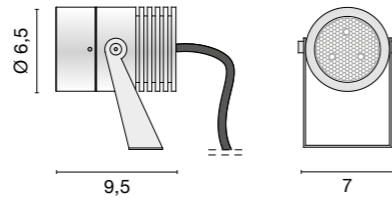

Accessories



0248

Picchetto
Stake

0243

Connettore stagno
IP Connector

Drivers

	0125	0126	0147/COB	0127	0129	0129/DALI	0145	0145/DALI	0115/EM
	350mA	700mA	500mA	500mA	DIM	DIM DALI	DIM	DIM DALI	EMERGENCY
4511	1-2	NO	NO	1-2	1-3	1-4	1-6	1-6	NO
4555	NO	NO	1-2	NO	1-2	1-2	1-3	1-3	1

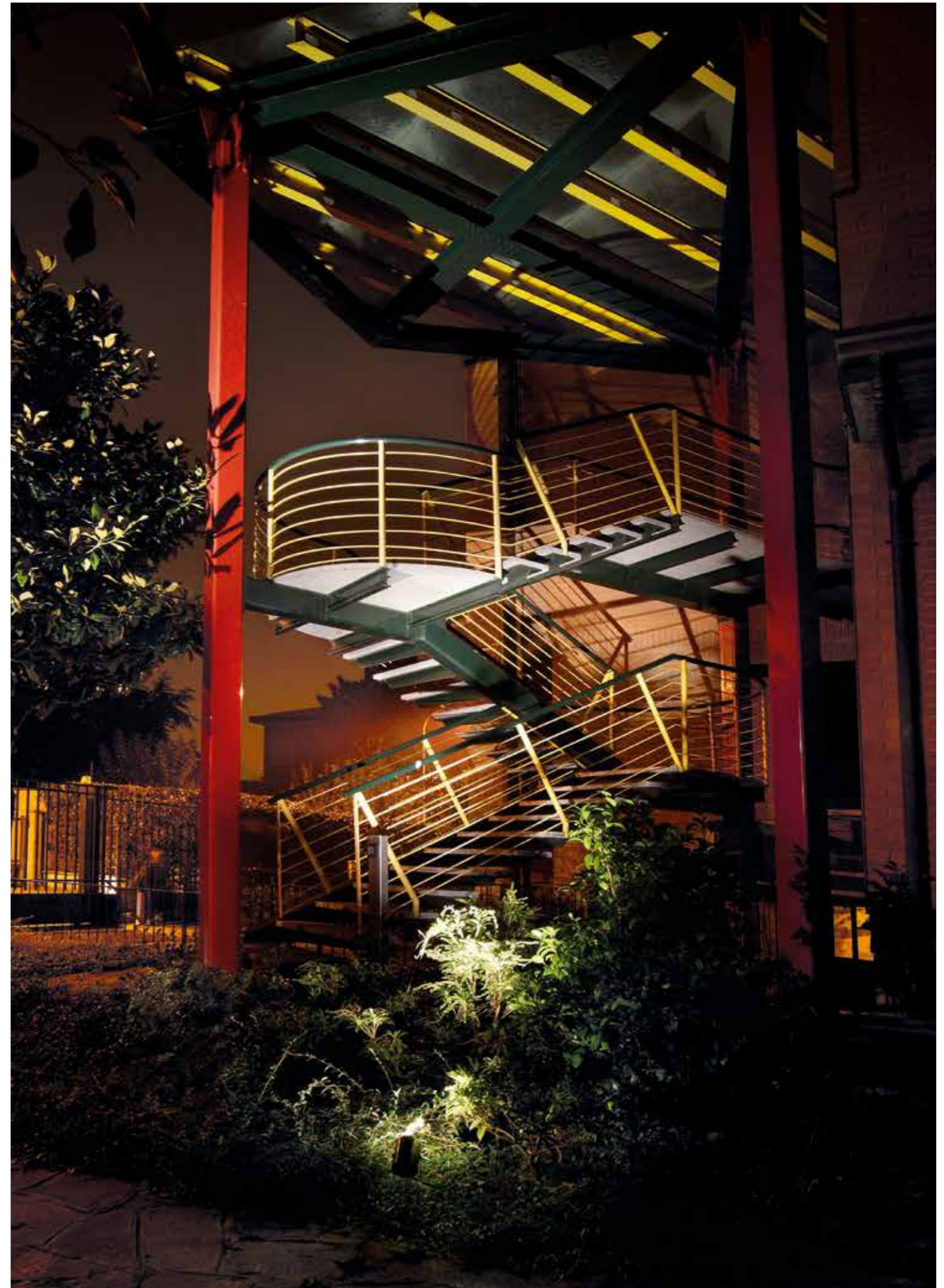



Serie di faretti da incasso calpestabili (IP 67) con flangia in acciaio INOX AISI 316L, dissipatore in alluminio e cavo in neoprene da 30 cm. Disponibili in versioni tonde e quadrate. Montaggio con cassaforma o in cartongesso con apposito accessorio.

Versione ETL disponibile a richiesta

Series of walkover recessed spots (IP 67) with frame in stainless steel AISI 316L, heat sink in aluminum and neoprene cable 30 cm. Available in round and square versions. Mounting with recessed box or in plasterboards by means of a specific accessory.

ETL version available upon request

Serie de spots encastrable piétinable (IP67). Cadre en acier INOX AISI316L et dissipateur en aluminium. Câble en néoprène de 30 cm. Verre de protection satiné. Montage avec boîte d'encastrement ou dans le placoplâtre avec accessoire spécifique.

Version ETL disponible sur demande

Begehbarer Einbaustrahler (IP67). Rahme aus rostfreier Stahl AISI316L und Kühlkörper aus Aluminium. Neopren Stromkabel 30 cm. Inbegriffen. Satiniertes Schutzglas. Montage mit Einbaugeschäube oder im Gipskarton mit spezifischem Zubehör.

Serie de focos pisables para empotrar (IP67) con brida en acero INOX AISI316L y disipador de calor en aluminio. Cable de neopreno de 30 cm. Cristal de protección satinado. Montaje con cajetín o, en paneles de yeso, utilizando el accesorio específico.

Встроенные светильники из нержавеющей стали марки AISI316L для пешеходных зон. IP67. С радиатором для отвода тепла и кабелем из неопрена 30 см. Круглые или квадратные. Монтируется с монтажной коробкой или в гипсокартон с помощью специального аксессуара.

ZEPPELIN

design: U.T. EGOLUCE

Outdoor



Molla per cartongesso inclusa
Spring for plasterboard included
⌀ 3,2 cm.



6348 zeppelin tondo	0,1 kg
/WW Led max 2W 500mA 199lm 3000K	73°
/W Led max 2W 500mA 209lm 4000K	73°
F III IP67	500 kg T<40°C 30 cm

6349 zeppelin quadro	0,1 kg
/WW Led max 2W 500mA 199lm 3000K	73°
/W Led max 2W 500mA 209lm 4000K	73°
F III IP67	500 kg T<40°C 30 cm

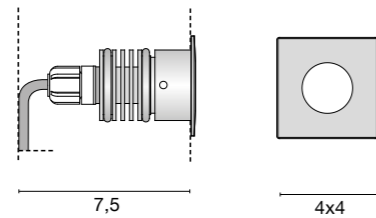
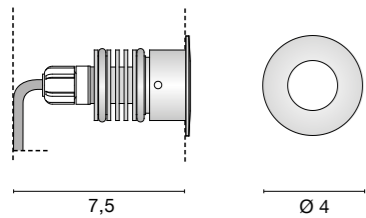

.33/W .33/WW Inox AISI 316L ⌀ 3 cm.

.33/W .33/WW Inox AISI 316L ⌀ 3 cm.

Accessories



Drivers



ZEPPELIN RGB

design: U.T. EGOLUCE

Outdoor



Molla per cartongesso inclusa
Spring for plasterboard included
⌀ 3,2 cm.



6376 zeppelin RGB tondo 0,2 kg

Led 3x250mA

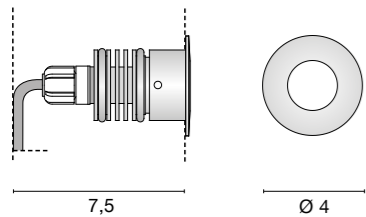
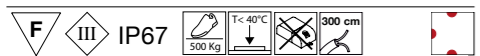

.33 Inox AISI 316L ⌀ 3 cm.

6395 zeppelin RGB quadro 0,2 kg

Led 3x250mA

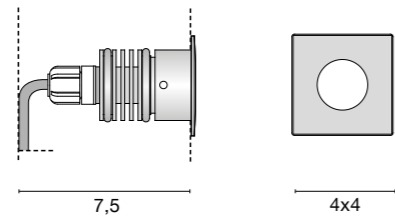
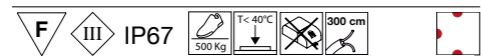

.33 Inox AISI 316L ⌀ 3 cm.

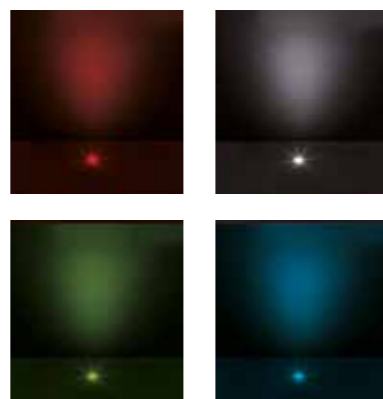

Accessories



Drivers



ZEPPELIN 25 PLUS

design: U.T. EGOLUCE

Outdoor

Outdoor



Molla per cartongesso inclusa
Spring for plasterboard included

3,2 cm.

6384 zeppelin 25 plus tondo

0,1 kg



.33 Inox AISI 316L

3 cm.

Source LED cod.	OPTIC degree	Im	LED color
/WW	/11 /25 /45	Led max 2W 500mA 199lm	3000K
/W	/11 /25 /45	Led max 2W 500mA 209lm	4000K

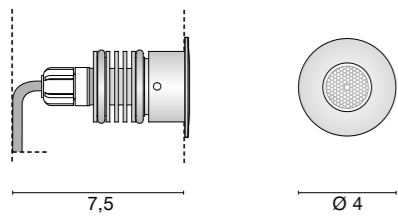

6394 zeppelin 25 plus quadro

0,1 kg



.33 Inox AISI 316L

3 cm.

Source LED cod.	OPTIC degree	Im	LED color
/WW	/11 /25 /45	Led max 2W 500mA 199lm	3000K
/W	/11 /25 /45	Led max 2W 500mA 209lm	4000K

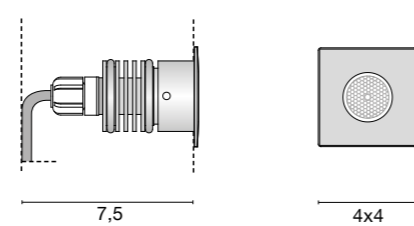

Accessories



0216
Plastic Box

0220
Cassaforma + Connettore IP
Junction box + IP Connector

Drivers



0125 350 mA
(1-6 Zeppelin Plus)

0127 500 mA
(1-6 Zeppelin Plus)

0128 350 mA
(1-10 Zeppelin Plus)

0031/IP 350 mA
(1-10 Zeppelin Plus)

0143/IP 500 mA
(1-7 Zeppelin Plus)

0129 Dimmer
0129/DALI Dimmer

0145 Dimmer Maxi
0145/DALI Dimmer M.



ZEPPELIN MAXI COB

design: U.T. EGOLUCE

Outdoor



6397 0,3 kg



.33 Inox AISI 316L 6 cm.

Source LED cod.	OPTIC degree		lm	LED color
/WW	128 160	9,2W 18,4V 500mA	1056lm	3000K
/W	128 160	9,2W 18,4V 500mA	1115lm	4000K

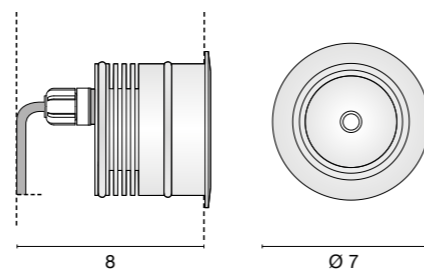

Accessories



0230
Cassaforma + Connettore IP
Junction box + IP Connector

0260/C
Molla per cartongesso
Spring for plasterboard
6 cm.

Drivers



0147/COB 500 mA (1-2 Zeppelin COB) **0143/IP** 500 mA (1 Zeppelin COB) **0129 Dimmer** **0129/DALI** Dimmer **0145 Dimmer Maxi** **0145/DALI** Dimmer M.



Outdoor

ZEPPELIN MAXI

design: U.T. EGOLUCE

Outdoor



6368 zeppelin maxi tondo 0,3 kg

/WW Led max 3x1W 350mA 429lm 3000K

/W Led max 3x1W 350mA 453lm 4000K

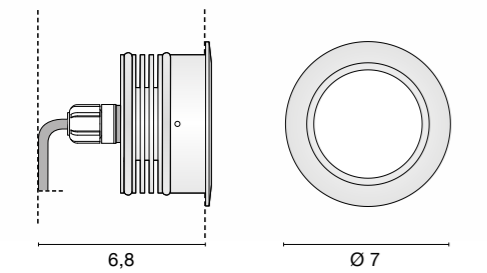

.33/W .33/WW Inox AISI 316L 6 cm.

6383 zeppelin maxi quadro 0,3 kg

/WW Led max 3x1W 350mA 429lm 3000K

/W Led max 3x1W 350mA 453lm 4000K

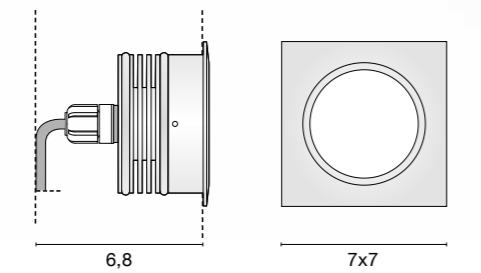
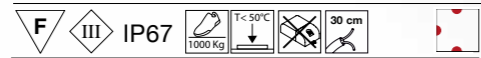

.33/W .33/WW Inox AISI 316L 6 cm.

Accessories



Drivers



ZEPPELIN orientabile

design: U.T. EGOLUCE

Outdoor



6411 0,2 kg



.33 Inox AISI 316L 6 cm.

Source LED cod.	OPTIC degree	lm	LED color
/WW	/11 /25 /45	Led max 2W 500mA 199lm	3000K
/W	/11 /25 /45	Led max 2W 500mA 209lm	4000K

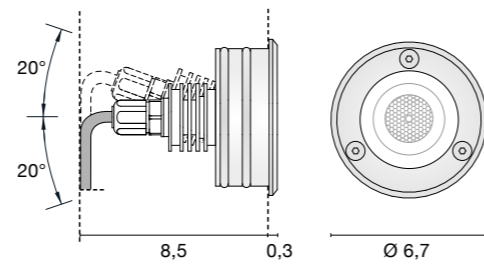

Accessories

 <p>0230 Cassaforma + Connettore IP Junction box + IP Connector</p>	 <p>0232 Cassaforma Junction box</p>	 <p>0238 Molla per cartongesso Spring for plasterboard 6 cm.</p>
--	--	--

Drivers

 <p>0125 350 mA (1-6 Zeppelin)</p>	 <p>0127 500 mA (1-6 Zeppelin)</p>	 <p>0128 350 mA (1-10 Zeppelin)</p>	 <p>0031/IP 350 mA (1-10 Zeppelin)</p>	 <p>0143/IP 500 mA (1-7 Zeppelin)</p>	 <p>0129 Dimmer 0129/DALI Dimmer</p>	 <p>0145 Dimmer Maxi 0145/DALI Dimmer M.</p>
---	--	---	--	---	---	---

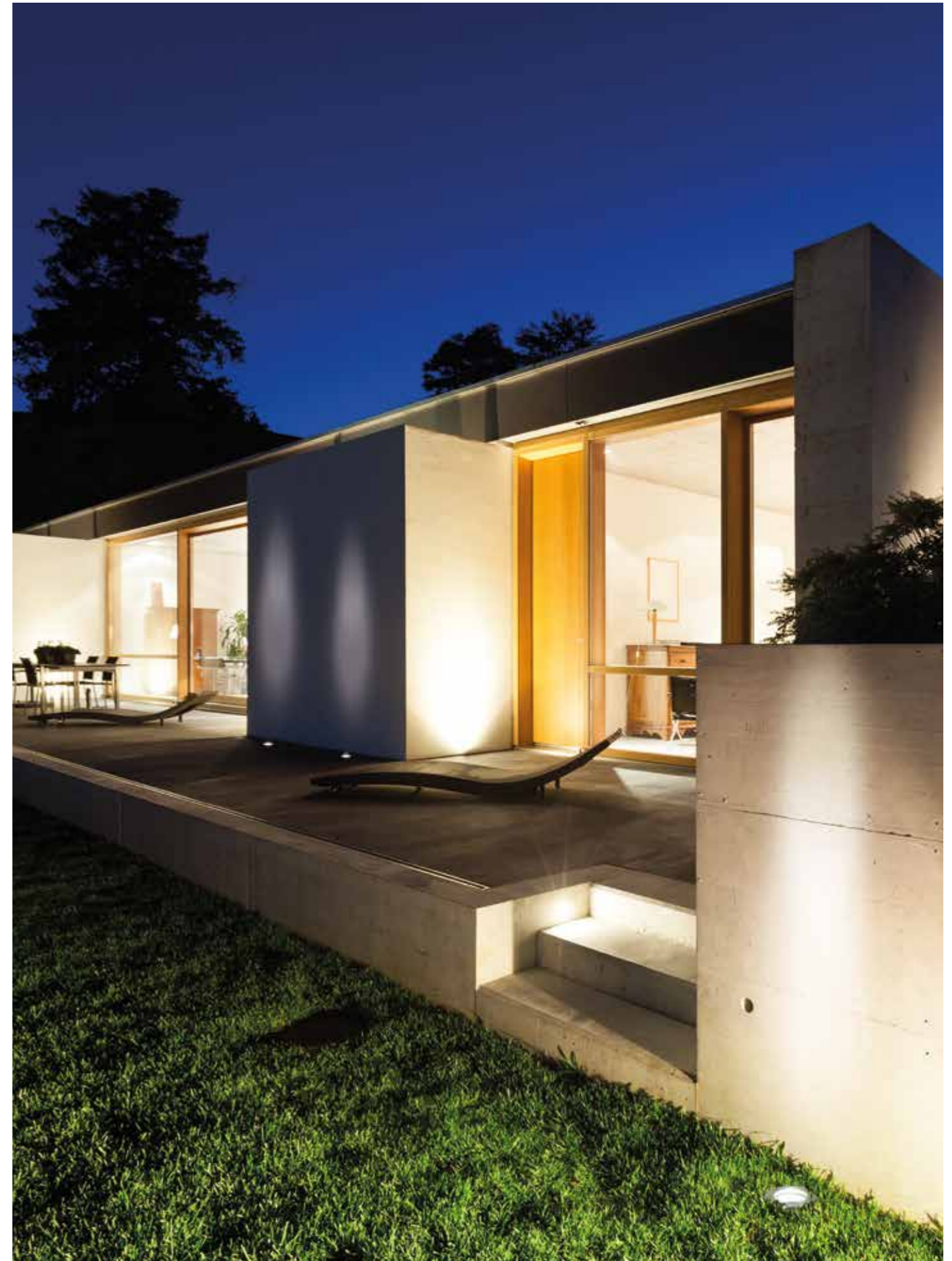

Outdoor



Faretto da incasso calpestabile da esterno (IP 67) con flangia in acciaio INOX AISI 316L e dissipatore in alluminio. Cavo in neoprene da 30 cm. Vetro di protezione trasparente. Montaggio con cassafornice o in cartongesso con apposito accessorio (art. 0233).

Versione ETL disponibile a richiesta

Walkover recessed outdoor spot (IP 67) with frame in stainless steel AISI 316L and heat sink in aluminium. Neoprene cable 30 cm. Transparent safety glass. Mounting with recessed box or in plasterboards by means of a specific accessory (art. 0233). **ETL version available upon request**

Spot encastrable piétinable pour extérieur (IP67). Cadre en acier INOX AISI316L et dissipateur en aluminium. Câble en néoprène 30 cm. Verre de protection transparent. Montage avec boîte d'encastrement ou dans le placoplâtre avec accessoire spécifique (art. 0233).

Version ETL disponible sur demande

Begehbarer Einbaustrahler für Außenbereich (IP67). Rahme aus rostfreier Stahl AISI316L und Kühlkörper aus Aluminium. Neopren Stromkabel 30 cm. inbegriffen. Transparentem Schutzglas. Montage mit Einbaugehäuse oder im Gipskarton mit spezifischem Zubehör (Art. 0233).

Foco empotrable pisable para exterior (IP67) con brida en acero INOX AISI316L y disipador de calor en aluminio. Cable de neopreno da 30 cm. Cristal de protección transparente. Montaje con cajetín o, en paneles de yeso, utilizando el accesorio específico (art. 0233).

Встроенный светильник из нержавеющей стали марки AISI316L для пешеходных зон. IP67. С радиатором для отвода тепла и кабелем из неопрена 30 см. Диффузор из прозрачного стекла. Монтируется с монтажной коробкой или в гипсокартон с помощью специального аксессуара (art. 0233)

6371 0,4 kg



.33 Inox AISI 316L

Source LED cod.	OPTIC degree	lm	LED color
/WW	/10 /25 /40	Led max 3x2W 500mA 597lm	3000K
/W	/10 /25 /40	Led max 3x2W 500mA 627lm	4000K

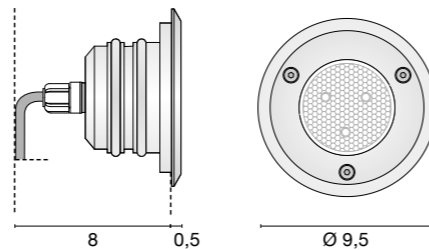

Accessories

<p>0231 Cassafornice + Connettore IP Junction box + IP Connector</p>	<p>0235 Cassafornice Junction box</p>	<p>0243 Connettore stagno IP IP Connector</p>	<p>0233 Molla per cartongesso Spring for plasterboard 8,5 cm.</p>
---	--	--	--

Drivers

<p>0125 350 mA (1-2 Tris)</p>	<p>0127 500 mA (1-2 Tris)</p>	<p>0128 350 mA (1-3 Tris)</p>	<p>0031/IP 350 mA (1-3 Tris)</p>	<p>0143/IP 500 mA (1-2 Tris)</p>	<p>0129 Dimmer 0129/DALI Dimmer</p>	<p>0145 Dimmer Maxi 0145/DALI Dimmer M.</p>
--	--	--	---	---	---	---

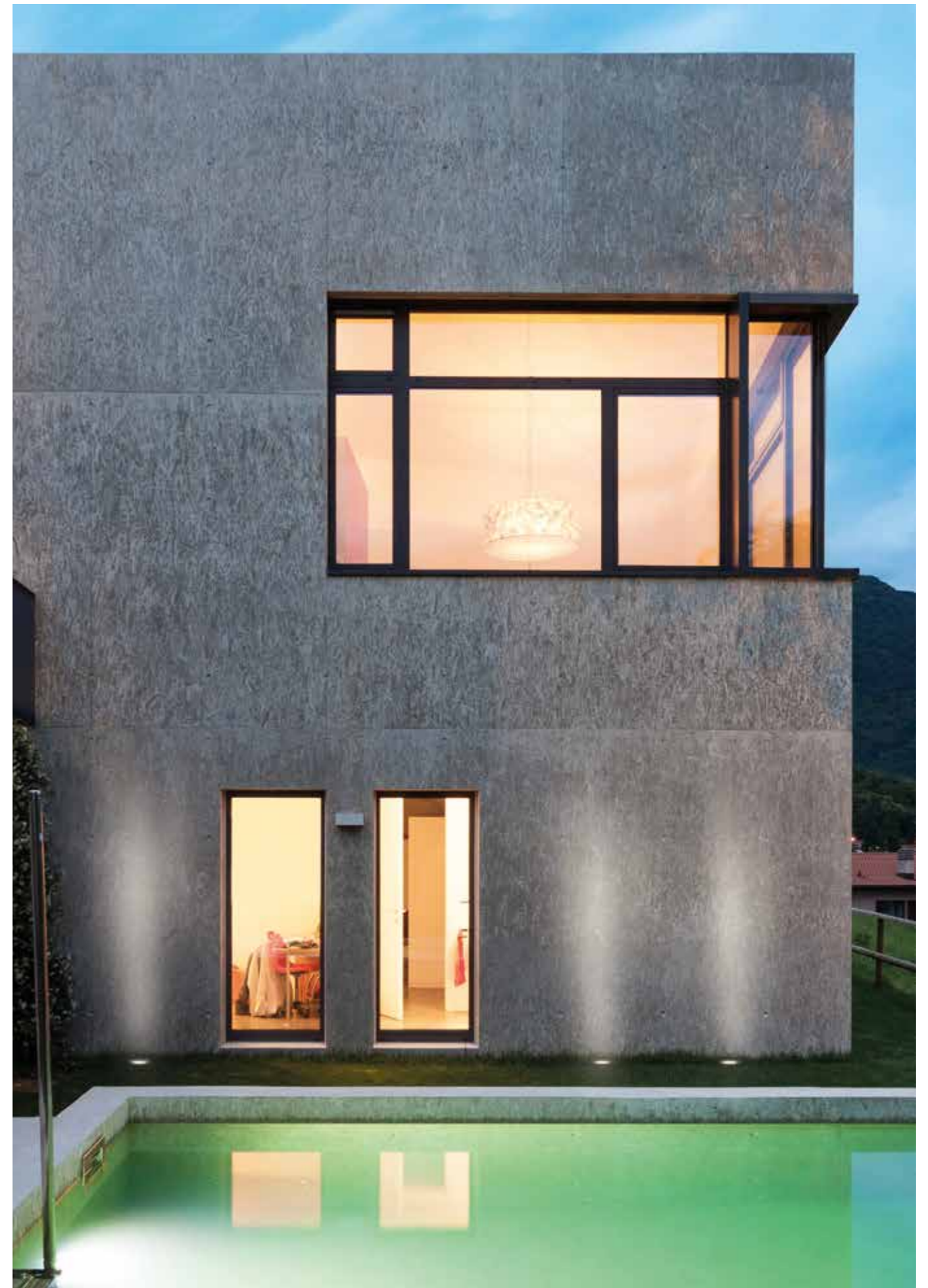

SOFT

design: U.T. EGOLUCE

Outdoor

Outdoor



Faretto da incasso calpestabile (IP 67) con flangia in acciaio INOX AISI 316L. Vetro di protezione satinato. Cavo in neoprene da 30 cm. COLLEGAMENTO IN PARALLELO.

Versione ETL disponibile a richiesta

Recessed spot (IP 67) with frame in stainless steel AISI 316L.

Frosted safety glass Neoprene cable 30 cm. PARALLEL CONNECTION.

Versione ETL disponibile a richiesta

Spot encastrable piétinable (IP67). Cadre en acier INOX AISI316L et Verre de protection satiné. Câble en néoprène de 30 cm. MONTAGE EN PARALLÈLE.

Version ETL disponible sur demande

Einbaustrahler (IP67). Rahme aus rostfreier Stahl AISI316L. Satiniert glas. Neopren Stromkabel 30 cm.

NUR FÜR PARALLELVERBINDUNG.

Foco pisable para empotrar (IP67) con brida en acero INOX AISI316L Cristal de protección satinado. Cable en neoprene de 30 cm. CONEXIÓN EN PARALELO.

Встроенные светильники из нержавеющей стали марки IP67. С радиатором для отвода тепла и кабелем из неопрена 30 см.с кабелем из неопрена 30 см.

ПОДКЛЮЧЕНИЕ ПАРАЛЛЕЛЬНОЕ.

6388 0,1 kg

/ww Led 1,5W 12V 3000K

/w Led 1,5W 12V 4000K

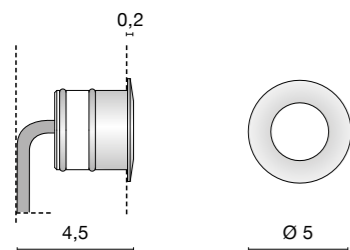

.33/W .33/WW Inox AISI 316L 3,8 cm.

Accessories



0217
Plastic Box



0250
Cassaforma + Connettore IP
Junction box + IP Connector

Drivers



0159
(1-15 Soft)



0129 Dimmer
0129/DALI Dimmer



0036/IP
(1-8 Soft)



CERCHIO

design: U.T. EGOLUCE

Outdoor



Molla per cartongesso inclusa.
Spring for plasterboard included

4 cm.

Faretto da incasso calpestabile (IP 67) con flangia in acciaio INOX AISI 316L e dissipatore in alluminio. Cavo in neoprene da 30 cm. Disponibile con LED bianco o blu. Montaggio con o senza casseforme.

Versione ETL disponibile a richiesta

Walkover recessed spot (IP 67) with frame in stainless steel AISI 316L and aluminum heat sink. Neoprene cable 30 cm. Available with white or blue LED. Mounting with or without recessed box.

ETL version available upon request

Spot encastrable piétinable (IP 67) en acier INOX AISI316L et dissipateur de chaleur en aluminium. Câble en néoprène de 30 cm. Disponible avec LED blanc ou bleu. Montage avec ou sans boîte d'encastrement.

Version ETL disponible sur demande

Begehrbarer Einbaustrahler (IP 67). Rahme aus rostfreier Stahl AISI316L und Kühlkörper aus Aluminium. Neopren Stromkabel 30 cm. LED Einheit weiß oder blau. Montage mit oder ohne Einbaugehäuse.

Foco pisable para empotrar (IP 67) con brida en acero INOX AISI316L y dissipador de calor en aluminio. Cable en neoprene de 30 cm. Disponible con LED blanco o azul. Montaje con o sin cajetín.

Встроенный светильник (IP 67) для пешеходных зон из нержавеющей стали марки AISI316L, с кабелем из неопрена 30 см. Радиатор для отвода тепла из алюминия. С белым или синим светодиодом. Монтируется с монтажной коробкой или без нее.

6389 0,2 kg

WW Led max 2W 500mA 199lm 3000K

W Led max 2W 500mA 209lm 4000K

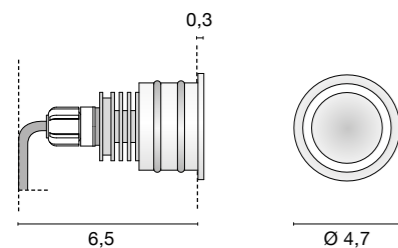
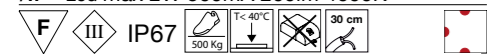

.33/W .33/WW .33/B Inox AISI 316L 3,8 cm.



Accessories



Drivers

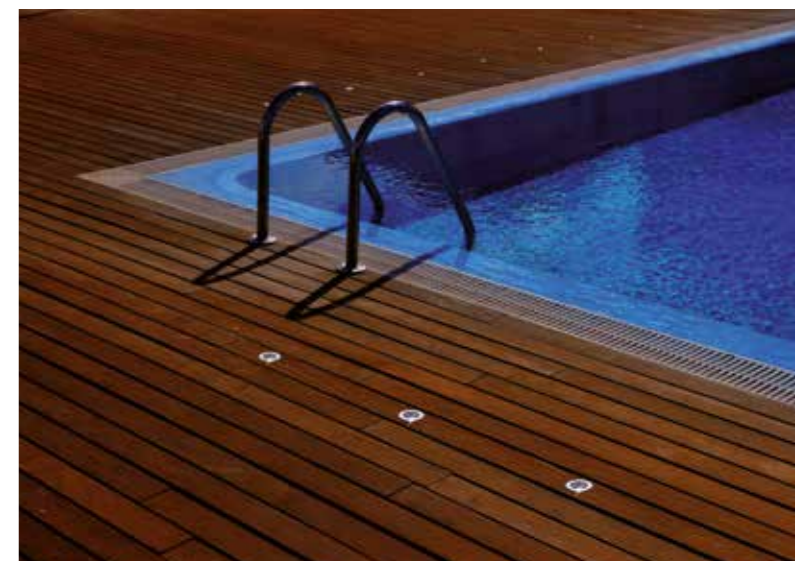

CERCHIO RGB

design: U.T. EGOLUCE

Outdoor



Molla per cartongesso inclusa.
Spring for plasterboard included
⌀ 4 cm.

Faretto da incasso calpestabile (IP 67) con flangia in acciaio INOX AISI 316L e dissipatore in alluminio. Cavo in neoprene da 30 cm. Montaggio con o senzacasceforme.
Versione ETL disponibile a richiesta

Spot encastrable piétinable (IP 67) en acier INOX AISI316L et dissipateur de chaleur en aluminium. Câble en néoprène de 30 cm. Montage avec ou sans bote d'encastrement.
Version ETL disponible sur demande

Foco pisable para empotrar (IP 67) con brida en acero INOX AISI316L y disipador de calor en aluminio. Cable en neoprene de 30 cm. Montaje con o sin cajetín.

Walkover recessed spot (IP 67) with frame in stainless steel AISI 316L and aluminum heat sink. Neoprene cable 30 cm. Mounting with or without recessed box.
ETL version available upon request

Begehbarer Einbaustrahler (IP 67). Rahme aus rostfreier Stahl AISI316L und Kühlkörper aus Aluminium. Neopren Stromkabel 30 cm. Montage mit oder ohne Einbaugehäuse.

Встроенный светильник (IP 67) для пешеходных зон из нержавеющей стали марки AISI316L, с кабелем из неопрена 30 см. Радиатор для отвода тепла из алюминия. Монтируется с монтажной коробкой или без нее.

6390 0,3 kg

Led 3 x 250mA
F III IP67 T<40°C 500 Kg 300 cm

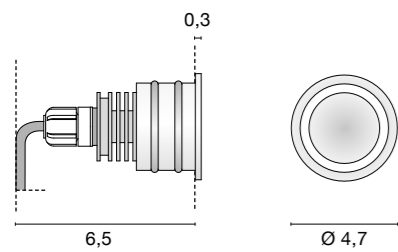

.33 Inox AISI 316L ⌀ 3,8 cm.

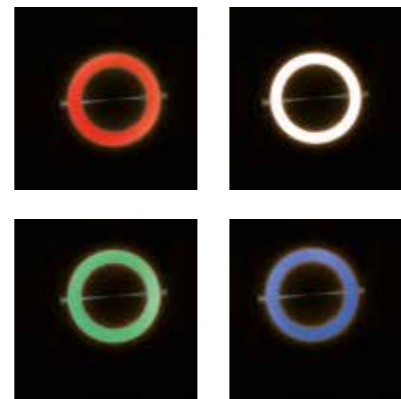

Accessories



Drivers

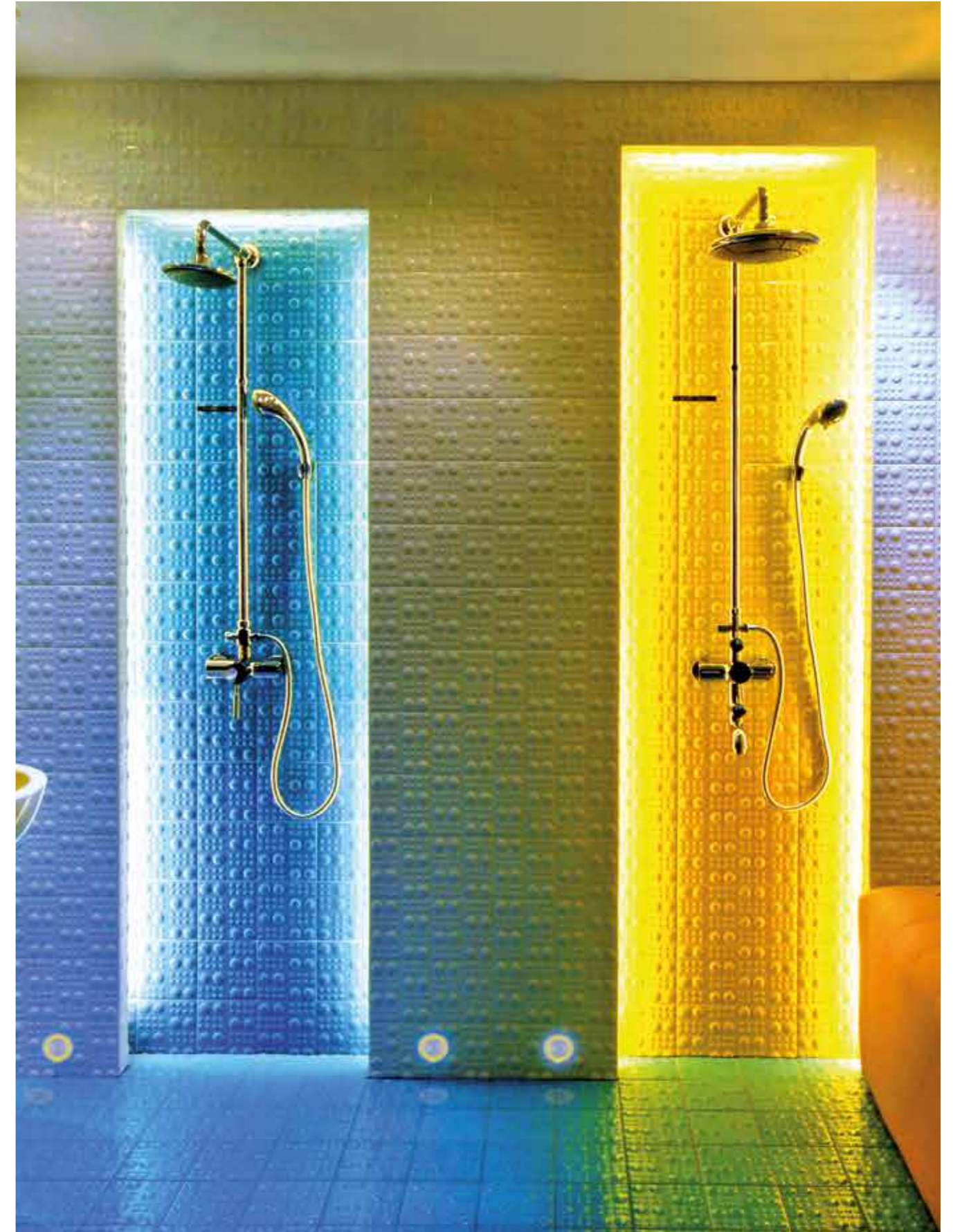

Outdoor

STEP

design: U.T. EGOLUCE

Outdoor



Faretto da incasso esterno (IP 55) a luce asimmetrica in alluminio anodizzato (finitura rinforzata per esterno) o verniciato bianco con cavo in neoprene da 30 cm. Disponibile in versione tonda e quadra. Montaggio con cassaforma.

Versione ETL disponibile a richiesta

Outdoor recessed spot (IP 55) for asymmetric light in anodized aluminium (reinforced anodizing for outdoor) or white lacquered finish. Neoprene cable 30 cm. Available in round and square version. Mounting with recessed box.

ETL version available upon request

Spot encastrable extérieur (IP55) pour émission asymétrique en aluminium anodisé (anodisation renforcée pour extérieur) ou verni blanc. Câble en néoprène 30 cm. inclus. Versions ronde et carré. Montage avec boîte d'encastrement.

Version ETL disponible sur demande

Einbaustrahler (IP55) für asymmetrische Ausstrahlung. Körper aus Aluminium eloxiert (verstärktem Eloxierung für Außenbereich) oder weiß lackiert. Neopren Stromkabel 30 cm. inbegriffen. Montage mit Einbaugehäuse.

Foco para empotrar (IP55) con luz asimétrica en aluminio anodizado (anodización reforzada para exterior) o pintado blanco. Cable de neopreno de 30 cm. Disponible en redondo y cuadrado. Montaje con cajetín.

Встроенный светильник с асимметричным лучом света из анодированного (усиленное анодирование для улицы) или окрашенного в белый цвет алюминия. IP55. С кабелем из неопрена 30 см. Круглый или квадратный. Монтируется с монтажной коробкой.

6387 Step Tondo 0,4 kg

/WW Led max 2W 500mA 199lm 3000K

/W Led max 2W 500mA 209lm 4000K

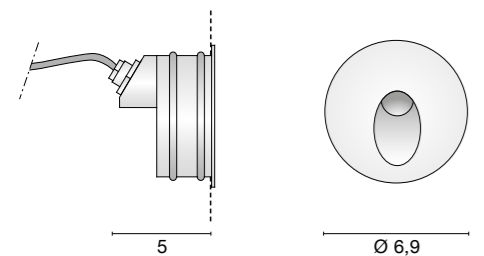

.01/W .01/WW .45/W .45/WW 6 cm.

6369 Step Quadro 0,4 kg

/WW Led max 2W 500mA 199lm 3000K

/W Led max 2W 500mA 209lm 4000K

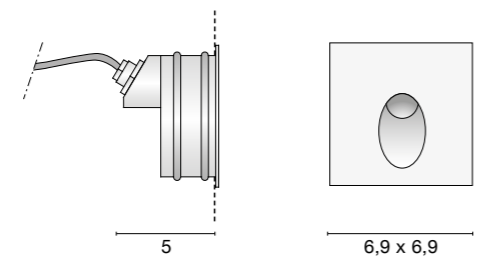

.01/W .01/WW .45/W .45/WW 6 cm.

Accessories



0232
Plastic Box



0243
Connettore stagno IP
IP Connector

Drivers



0125 350 mA
(1-6 Step)



0127 500 mA
(1-6 Step)



0128 350 mA
(1-10 Step)



0031/IP 350 mA
(1-10 Step)



0143/IP 500 mA
(1-7 Step)



0129 Dimmer
0129/DALI Dimmer



0145 Dimmer Maxi
0145 /DALI Dimmer M.

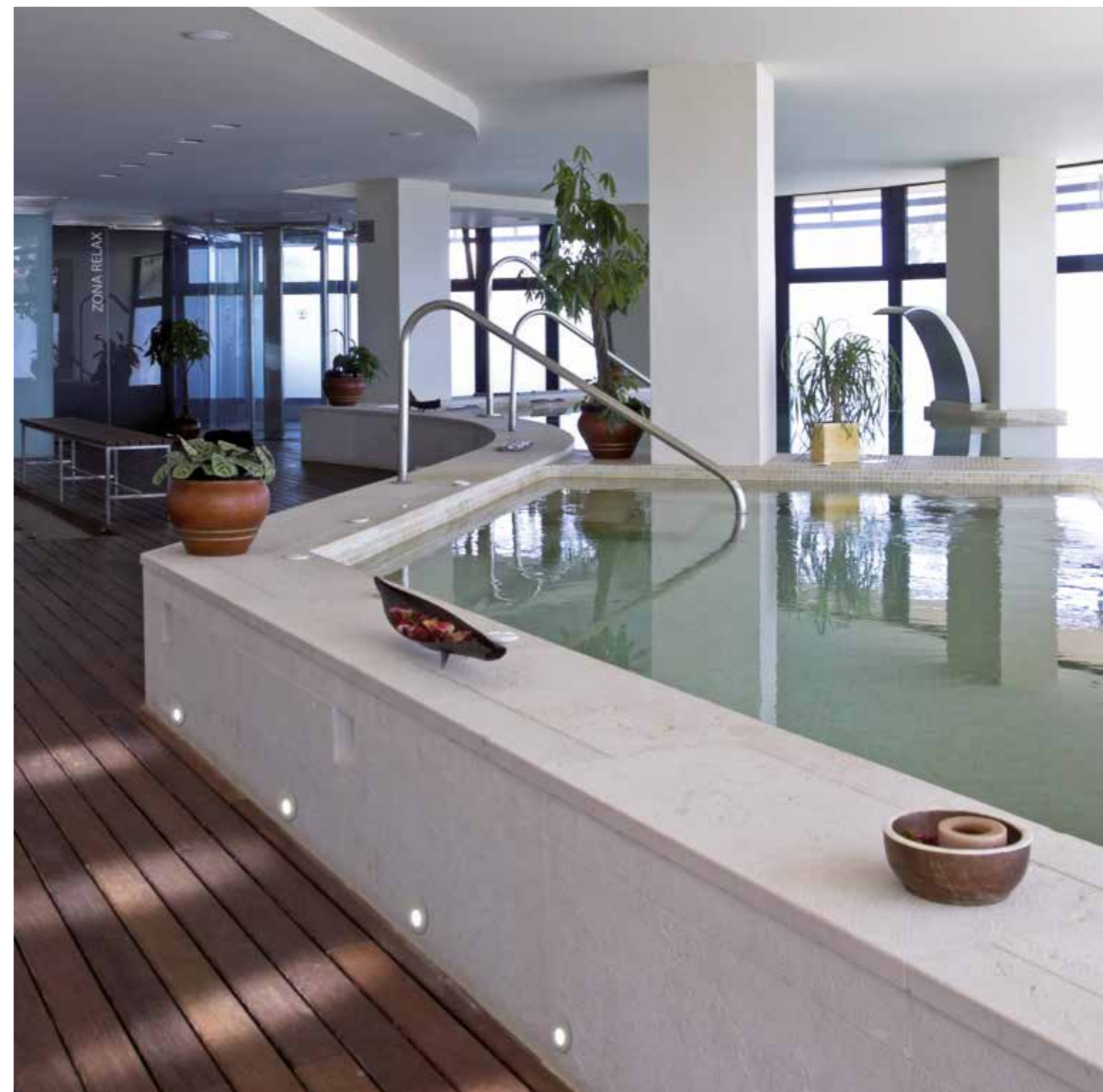



Molla per cartongesso inclusa
Spring for plasterboard included
⌀ 3,2 cm.

Faretto da incasso calpestabile (IP 67) con flangia in acciaio INOX AISI 316L e dissipatore in alluminio. Cavo in neoprene da 30 cm. Disponibile con LED bianco o blu. Montaggio con o senza casseforme.

Versione ETL disponibile a richiesta

Walkover recessed spot (IP 67) with frame in stainless steel AISI 316L and aluminum heat sink. Neoprene cable 30 cm. Available with white or blue LED. Mounting with or without recessed box.

ETL version available upon request

Spot encastré piétinable (IP 67) en acier INOX AISI316L et dissipateur de chaleur en aluminium. Câble en néoprène de 30 cm. Disponible avec LED blanc ou bleu. Montage avec ou sans boîte d'encastrement.

Version ETL disponible sur demande

Begehbarer Einbaustrahler (IP 67). Rahme aus rostfreier Stahl AISI316L und Kühlkörper aus Aluminium. Neopren Stromkabel 30 cm. LED Einheit weiß oder blau. Montage mit oder ohne Einbaugehäuse.

Foco pisabile para empotrar (IP 67) con brida en acero INOX AISI316L y disipador de calor en aluminio. Cable en neoprene de 30 cm. Montaje con o sin cajetín.

Встроенный светильник (IP 67) для пешеходных зон из нержавеющей стали марки AISI316L, с кабелем из неопрена 30 см. Радиатор для отвода тепла из алюминия. С белым или синим светодиодом. Монтируется с монтажной коробкой или без нее.

6361 0,2 kg

/WW Led max 2W 500mA 199lm 3000K

/W Led max 2W 500mA 209lm 4000K

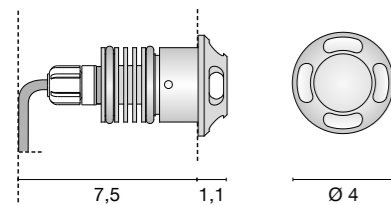

.33/W .33/WW .33/B Inox AISI 316L ⌀ 3 cm.

Accessories



0216
Plastic Box



0220
Cassaforma + Connettore IP
Junction box + IP Connector

Drivers



0125 350 mA
(1-6 Kross)



0127 500 mA
(1-6 Kross)



0128 350 mA
(1-10 Kross)



0031/IP 350 mA
(1-10 Kross)



0143/IP 500 mA
(1-7 Kross)



0129 Dimmer
0129/DALI Dimmer



0145 Dimmer Maxi
0145/DALI Dimmer M.

.33/W

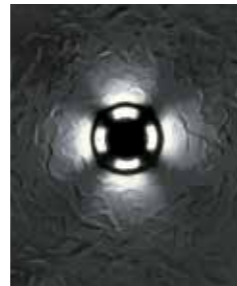

.33/WW

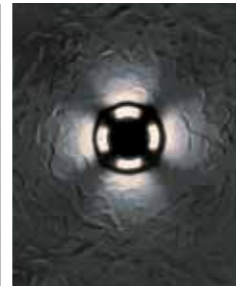

.33/B

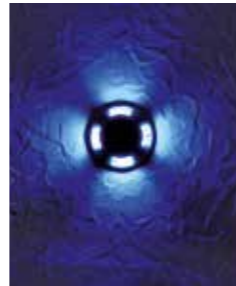

VISTA

design: U.T. EGOLUCE

Outdoor



Molla per cartongesso inclusa
Spring for plasterboard included

3,2 cm.

Faretto da incasso calpestabile (IP 67) con flangia in acciaio INOX AISI 316L e dissipatore in alluminio. Cavo in neoprene da 30 cm. Flangia con palpebra antiabbagliamento. Montaggio con o senza casseforme.

Versione ETL disponibile a richiesta

Walkover recessed spot (IP 67) with frame in stainless steel AISI 316L and aluminum heat sink. Neoprene cable 30 cm. Diffuser with anti-dazzling eyelid. Mounting with or without recessed box.

ETL version available upon request

Spot encastré piétinable (IP67) en acier INOX AISI316L et dissipateur de chaleur en aluminium. Câble en néoprène de 30 cm. Diffuseur avec cadre anti éblouissement. Montage avec ou sans boîte d'encastrement.

Version ETL disponible sur demande

Begehbarer Einbaustrahler (IP67). Rahme aus rostfreier Stahl AISI316L und Kühlkörper aus Aluminium. Neopren Stromkabel 30 cm. Diffusor mit Blendschutz. Montage mit oder ohne Einbaugehäuse.

Foco pisable para empotrar (IP67) con brida en acero INOX AISI316L y disipador de calor en aluminio. Cable de neoprene de 30 cm. Difusor anti deslumbramiento. Montaje con o sin cajetín.

Встроенный светильник (IP67) для пешеходных зон из нержавеющей стали марки AISI316L, с кабелем из неопрена 30см. Радиатор для отвода тепла из алюминия. Диффузор с защитой от ослепления. Монтируется с монтажной коробкой или без нее.

6362 0,1 kg

///w Led max 2W 500mA 199lm 3000K

/w Led max 2W 500mA 209lm 4000K

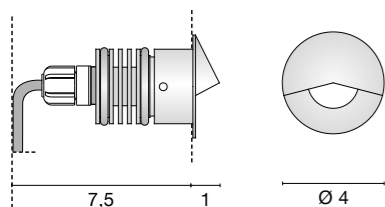
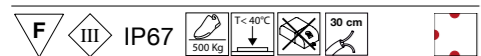

.33/W .33/WW Inox AISI 316L 3 cm.

Accessories



0216
Plastic Box



0220
Cassaforma + Connettore IP
Junction box + IP Connector

Drivers



0125 350 mA
(1-6 Vista)



0127 500 mA
(1-6 Vista)



0128 350 mA
(1-10 Vista)



0031/IP 350 mA
(1-10 Vista)



0143/IP 500 mA
(1-7 Vista)



0129 Dimmer
0129/DALI Dimmer



0145 Dimmer Maxi
0145/DALI Dimmer M.



DRIVE

design: U.T. EGOLUCE

Outdoor



Faretto da incasso carrabile (IP 67) con flangia in acciaio INOX AISI 316L, dissipatore in alluminio e cavo in neoprene da 30 cm. Diffusore in vetro serigrafato opalino. Montaggio con cassaforma.

Versione ETL disponibile a richiesta

Driveover recessed spot (IP 67) with frame in stainless steel AISI 316L and aluminum heat sink. Neoprene cable 30 cm. Diffuser in matt glass. Mounting with recessed box.

ETL version available upon request

Spot encastré conçu pour passage véhicules. (IP 67) en acier INOX AISI316L et dissipateur de chaleur en aluminium. Câble en néoprène de 30 cm. Verre de protection satiné. Montage avec boîte d'encastrement.

Version ETL disponible sur demande

Befahrbarer Einbaustrahler (IP 67). Rahme aus rostfreier Stahl AISI316L und Kühlkörper aus Aluminium. Neopren Stromkabel 30 cm. Satiniertes Schutzglas. Montage mit Einbaugeschäule.

Foco para empotrar (IP 67) para pasaje de vehículos. Brida en acero INOX AISI316L y dissipador de calor en aluminio. Cable de neoprene de 30 cm. Cristal de protección satinado. Montaje con cajetín.

Встроенный светильник (IP 67) для автомобильных зон из нержавеющей стали марки AISI316L, с кабелем из неопрена 30см. Радиатор для отвода тепла из алюминия. Матовое стекло экрана с защитой от ослепления. Монтируется с монтажной коробкой.

6366 0,4 kg

/WW Led max 3x1W 350mA 429lm 3000K

/W Led max 3x1W 350mA 453lm 4000K

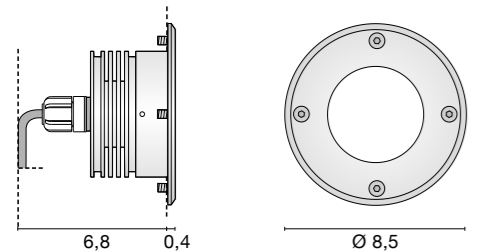

.33/W .33/WW Inox AISI 316L 6 cm.

Accessories



0229
Cassaforma + Connettore IP
Junction box + IP Connector

Drivers



0125 350 mA (1-2 Drive) **0128** 350 mA (1-3 Drive) **0031/IP** 350 mA (1-3 Drive) **0129** Dimmer (1-3 Drive) **0145** Dimmer Maxi (1-3 Drive)

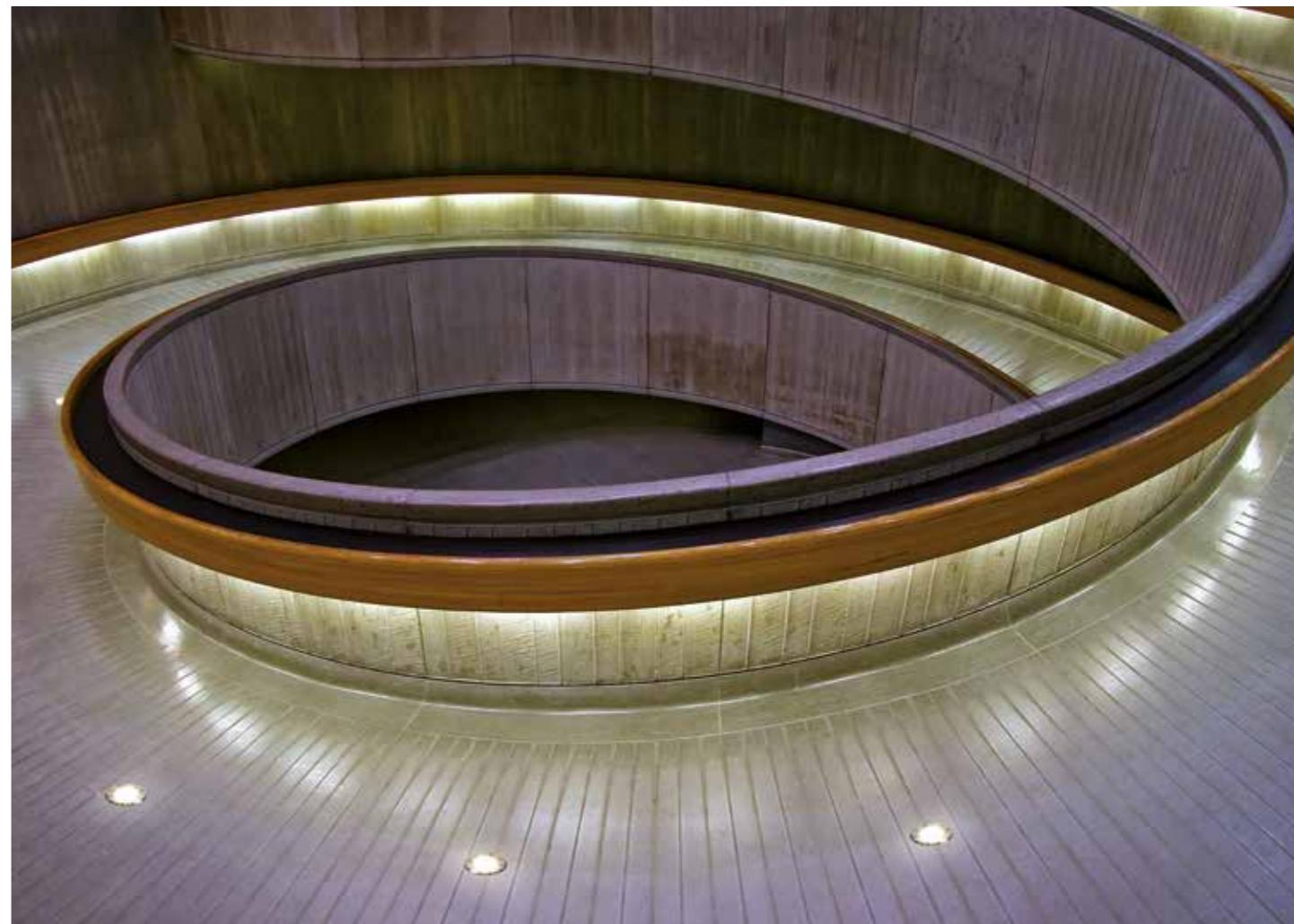

Outdoor

Profiles

EXTRA	p. 204
LANCIA	p. 210
PLANA	p. 216
MARGO	p. 220
INTO	p. 226
MAGIKA	p. 232
ASTRA	p. 238
COMETA IP20	p. 244

Projectors

NEWTON	p. 246
COLIBRÌ	p. 262
FLAN	p. 256

Track Spots

GALILEO	p. 250
COLIBRÌ	p. 256
FLAN	p. 266

Cables System

BIBOX HALO	p. 272
BIBOX SPOT	p. 274
BIBOX FLUO	p. 276

LIGHTING SYSTEMS

Apparecchi lineari LED, profilo in alluminio verniciato bianco RAL 9016 e diffusore in metacrilato satinato.

Terminali in ABS verniciato bianco.

Le versioni parete/soffitto sono munite di staffe di fissaggio a pressione posizionabili ovunque sulla lunghezza del prodotto.

Le sospensioni sono provviste di rosone/converter ed a richiesta sono realizzabili in soluzioni dimmerabili PUSH, 1...10V e DALI. Gli apparecchi sono disponibili in diverse misure (vedi tabella), tre tonalità di luce (2700, 3000 e 4000K), e versioni RGB solo per modelli parete/soffitto.

L'estruso permette il passaggio del cavo al suo interno per l'alimentazione del profilo successivo.

Cavo di alimentazione 200 cm.

Linear LED fixtures, aluminum profile in white finish RAL 9016 and satin methacrylate diffuser.

End pieces in white painted ABS.

Wall/ceiling options are provided with click mounting plates that can be positioned anywhere along the profile backside.

Suspension are complete of ceiling rose with converter, dimmable option PUSH, 1...10V, DALI available upon request.

Fixtures are available in different lengths (see table), three light tones (2700, 3000 and 4000K) or RGB only for ceiling/wall options. The profile allows internal passage of a cable to power next fitting.

Supply cable length 200 cm.

Appareils linéaires LED, profil en aluminium verni blanc (RAL9016) et diffuseur en méthacrylate satiné.

Terminales en ABS verni blanc.

Les versions mur/plafond sont fournies avec supports de montage à déclic qui peuvent être fixés n'importe où à l'arrière du produit.

Les suspensions incluent rosace avec convertisseur et se réalisent sur requête en version dimmable PUSH, 1...10V et DALI.

Les appareils sont disponibles en différentes longueurs (voir table), trois tonalités de lumière (2700, 3000, 4000K) ou RGB seulement pour versions mur/plafond.

Le profil permet le passage interne du câble d'alimentation de l'appareil suivant.

Longueur câble d'alimentation 200 cm.

Lineare LED Leuchte. Profil aus Aluminium matt weiß lackiert (RAL 9016) und Diffusor aus satiniertem Methacrylat. Endteile aus weiß lackiertem ABS.

Die Wand-/Deckenleuchten sind mit Klick-System Befestigungsteile geliefert, die auf der Rückseite der Profil freilich positioniert werden können.

Die Pendelleuchten sind komplett mit Baldachin inklusiv Konverter geliefert. Dimmbarkeit PUSH, 1...10V, DALI auf Anfrage.

Die einzelnen Segmente sind in verschiedene Länge (siehe Tabelle), drei Lichttonen (2700, 3000, 4000K) erhältlich.

RGB ist nur für Wand-/Deckenleuchte verfügbar.

Ausführungen mit Bewegungserkennung oder Sensordimmer sind auf Anfrage lieferbar.

Das Profil erlaubt die Durchführung der Speisekabel für eine weitere Leuchte.

Speisekabellänge 200 cm.

Luminarias lineales LED. Perfil de aluminio pintado blanco (RAL 9016) y difusor de metacrilato satinado.

Terminales en ABS pintado blanco.

Las versiones pared/techo se entregan con soportes de anclaje a presión que se pueden posicionar dondequiera atrás del producto.

Los colgantes incluyen florón con convertidor. Versiones con regulador PUSH, 1...10V, DALI se realizan a pedido.

Los aparatos son disponibles en varias larguras (ver tabla), tres temperaturas de luz (2700, 3000 y 4000K) y RGB solo para model techo/pared.

A pedido se realizan aparatos con sensor de movimiento o toque dimmer.

El perfil permite el pasaje del cable de alimentación por la luminaria siguiente.

Cable de alimentación 200 cm.

Линейный светодиодный светильник. Профиль из алюминия окрашен в белый цвет (RAL9016) рассеиватель из сатинового метакрилата.

Заглушки из окрашенного в белый цвет пластика.

Настенная и потолочная версия поставляются в комплекте с зажимами, которые могут крепиться в любом месте с обратной стороны профиля.

Подвесная версия состоит из потолочной базы с блоком питания. По запросу доступна опция диммирования PUSH, 1...10V, DALI.

Выпускается в различных стандартных длинах (см. таблицу), трех цветовых температурах (2700, 3000 и 4000K) или RGB(только Настенная и потолочная версия)

Внутри профиля может проходить кабель для питания следующего светильника.

Поставляется с кабелем длиной 200 см.



CUSTOM SIZE - Tabella lunghezze disponibili a richiesta. Table of available lengths on request.

cm.	watt	2700K (XW)	lm	3000K (WW)	lm	4000K (W)	lm
103,5	15W	A1560.01/100/XW	1780	1560.01/WW **	1900	A1560.01/100/W	2000
123,5	18W	A1560.01/120/XW	2136	A1560.01/120/WW	2280	A1560.01/120/W	2400
143,5	21W	A1560.01/140/XW	2492	A1560.01/140/WW	2660	A1560.01/140/W	2800
163,5	24W	A1560.01/160/XW	2848	A1560.01/160/WW	3040	A1560.01/160/W	3200
183,5	27W	A1560.01/180/XW	3204	A1560.01/180/WW	3420	A1560.01/180/W	3600
203,5	30W	A1560.01/200/XW	3560	A1560.01/200/WW	3800	A1560.01/200/W	4000
223,5	33W	A1560.01/220/XW	3916	A1560.01/220/WW	4180	A1560.01/220/W	4400
243,5	36W	A1560.01/240/XW	4272	A1560.01/240/WW	4560	A1560.01/240/W	4800
263,5	39W	A1560.01/260/XW	4628	A1560.01/260/WW	4940	A1560.01/260/W	5200
283,5	42W	A1560.01/280/XW	4984	A1560.01/280/WW	5320	A1560.01/280/W	5600
303,5	45W	A1560.01/300/XW	5340	A1560.01/300/WW	5700	A1560.01/300/W	6000

** Articolo standard a catalogo - Standard catalogue item

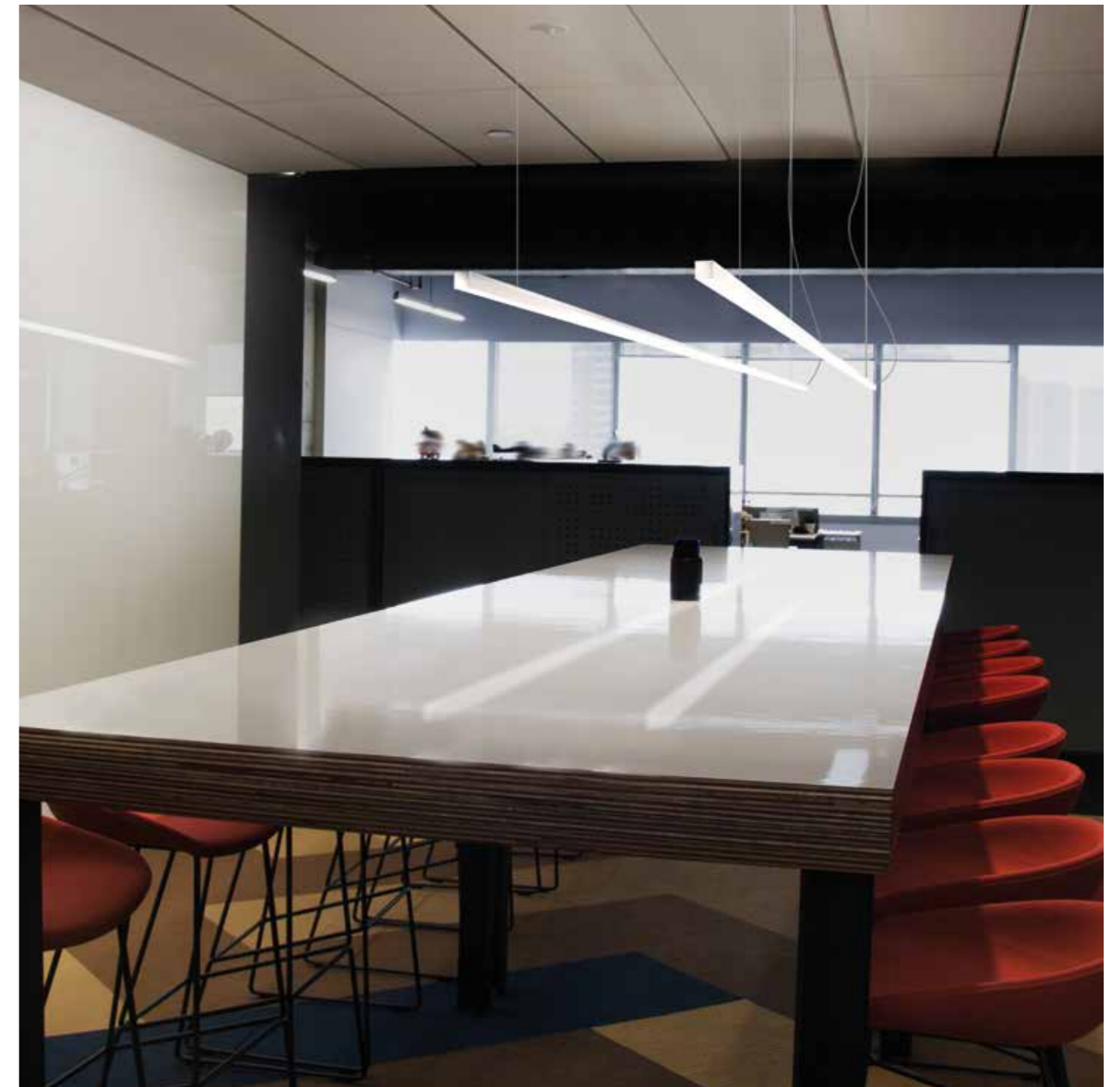

1560 0,15 kg

Led 15W 1900lm 3000K

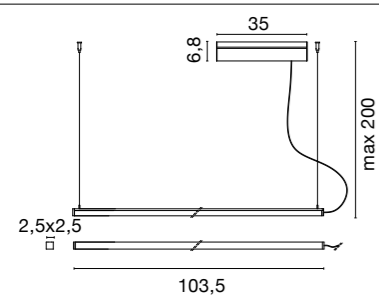
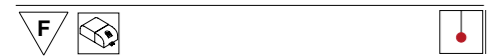

.01/WW



CUSTOM SIZE - Tabella lunghezze disponibili a richiesta. Table of available lengths on request.

cm.	watt	2700K (XW)	lm	3000K (WW)	lm	4000K (W)	lm
13,5	1,5W	A4521.01/10/XW	178	A4521.01/10/WW	190	A4521.01/10/W	200
23,5	3W	A4521.01/20/XW	356	A4521.01/20/WW	380	A4521.01/20/W	400
33,5	4,5W	A4521.01/30/XW	534	A4521.01/30/WW	570	A4521.01/30/W	600
43,5	6W	A4521.01/40/XW	712	A4521.01/40/WW	760	A4521.01/40/W	800
53,5	7,5W	A4521.01/50/XW	890	A4521.01/50/WW	950	A4521.01/50/W	1000
63,5	9W	A4521.01/60/XW	1068	A4521.01/60/WW	1140	A4521.01/60/W	1200
73,5	10,5W	A4521.01/70/XW	1246	A4521.01/70/WW	1330	A4521.01/70/W	1400
83,5	12W	A4521.01/80/XW	1424	A4521.01/80/WW	1520	A4521.01/80/W	1600
93,5	13,5W	A4521.01/90/XW	1602	A4521.01/90/WW	1710	A4521.01/90/W	1800
103,5	15W	A4521.01/100/XW	1780	4521.01/WW **	1900	A4521.01/100/W	2000
113,5	16,5W	A4521.01/110/XW	1958	A4521.01/110/WW	2090	A4521.01/110/W	2200
123,5	18W	A4521.01/120/XW	2136	A4521.01/120/WW	2280	A4521.01/120/W	2400
133,5	19,5W	A4521.01/130/XW	2314	A4521.01/130/WW	2470	A4521.01/130/W	2600
143,5	21W	A4521.01/140/XW	2492	A4521.01/140/WW	2660	A4521.01/140/W	2800
153,5	22,5W	A4521.01/150/XW	2670	A4521.01/150/WW	2850	A4521.01/150/W	3000
163,5	24W	A4521.01/160/XW	2848	A4521.01/160/WW	3040	A4521.01/160/W	3200
173,5	25,5W	A4521.01/170/XW	3026	A4521.01/170/WW	3230	A4521.01/170/W	3400
183,5	27W	A4521.01/180/XW	3204	A4521.01/180/WW	3420	A4521.01/180/W	3600
193,5	28,5W	A4521.01/190/XW	3382	A4521.01/190/WW	3618	A4521.01/190/W	3800
203,5	30W	A4521.01/200/XW	3560	A4521.01/200/WW	3800	A4521.01/200/W	4000
213,5	31,5W	A4521.01/210/XW	3738	A4521.01/210/WW	3990	A4521.01/210/W	4200
223,5	33W	A4521.01/220/XW	3916	A4521.01/220/WW	4180	A4521.01/220/W	4400
233,5	34,5W	A4521.01/230/XW	4094	A4521.01/230/WW	4370	A4521.01/230/W	4600
243,5	36W	A4521.01/240/XW	4272	A4521.01/240/WW	4560	A4521.01/240/W	4800
253,5	37,5W	A4521.01/250/XW	4450	A4521.01/250/WW	4750	A4521.01/250/W	5000
263,5	39W	A4521.01/260/XW	4628	A4521.01/260/WW	4940	A4521.01/260/W	5200
273,5	40,5W	A4521.01/270/XW	4806	A4521.01/270/WW	5130	A4521.01/270/W	5400
283,5	42W	A4521.01/280/XW	4984	A4521.01/280/WW	5320	A4521.01/280/W	5600
293,5	43,5W	A4521.01/290/XW	5162	A4521.01/290/WW	5510	A4521.01/290/W	5800
303,5	45W	A4521.01/300/XW	5340	A4521.01/300/WW	5700	A4521.01/300/W	6000

** Articolo standard a catalogo - Standard catalogue item

4521 0,15 kg

15W 24V 3000K

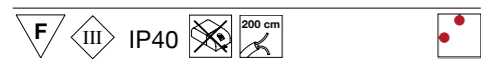

2,5x2,5

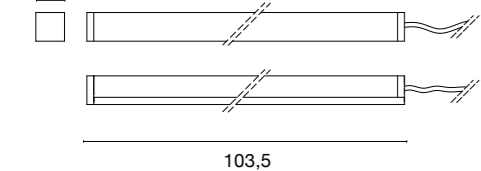

.01/WW

Drivers

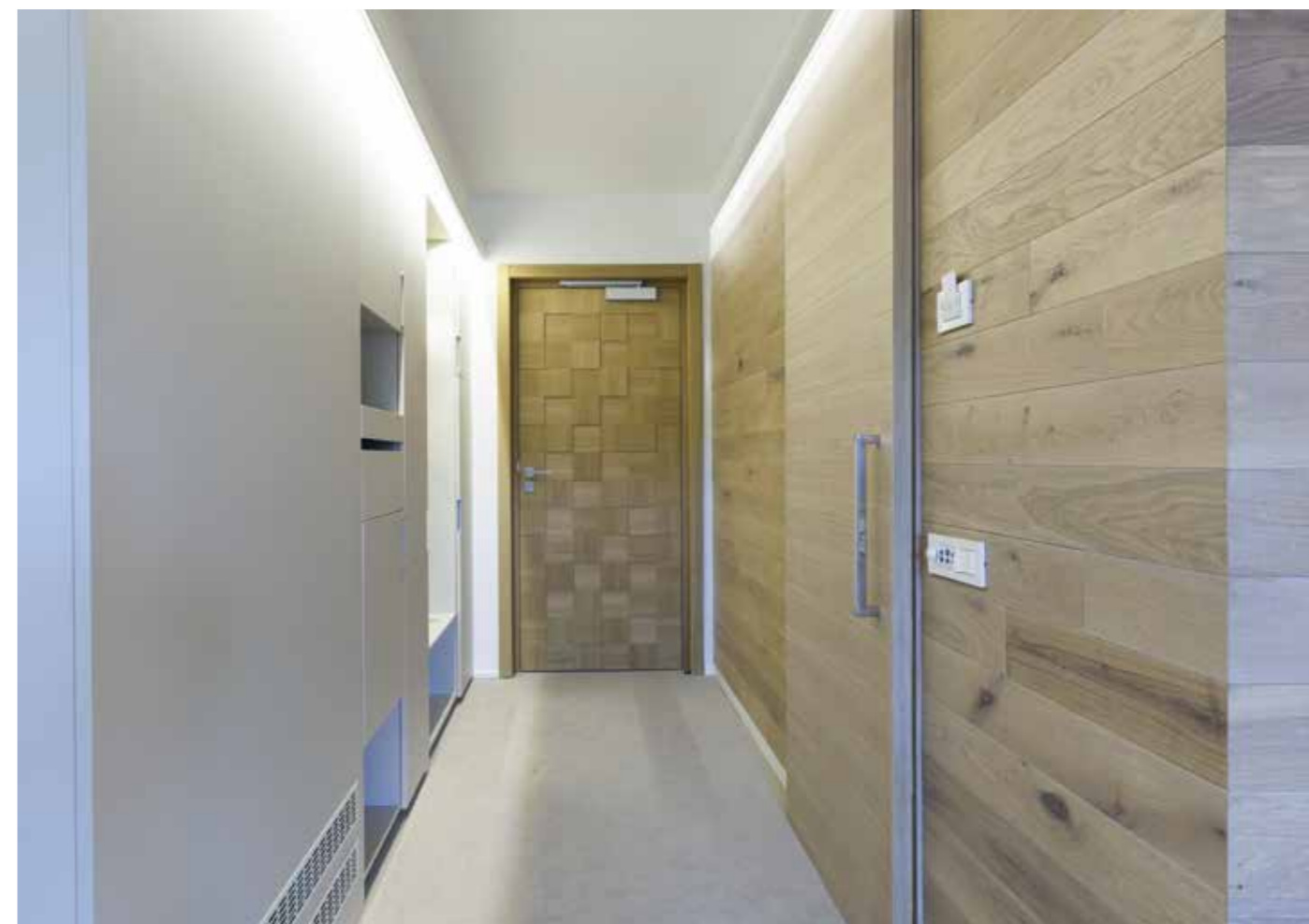

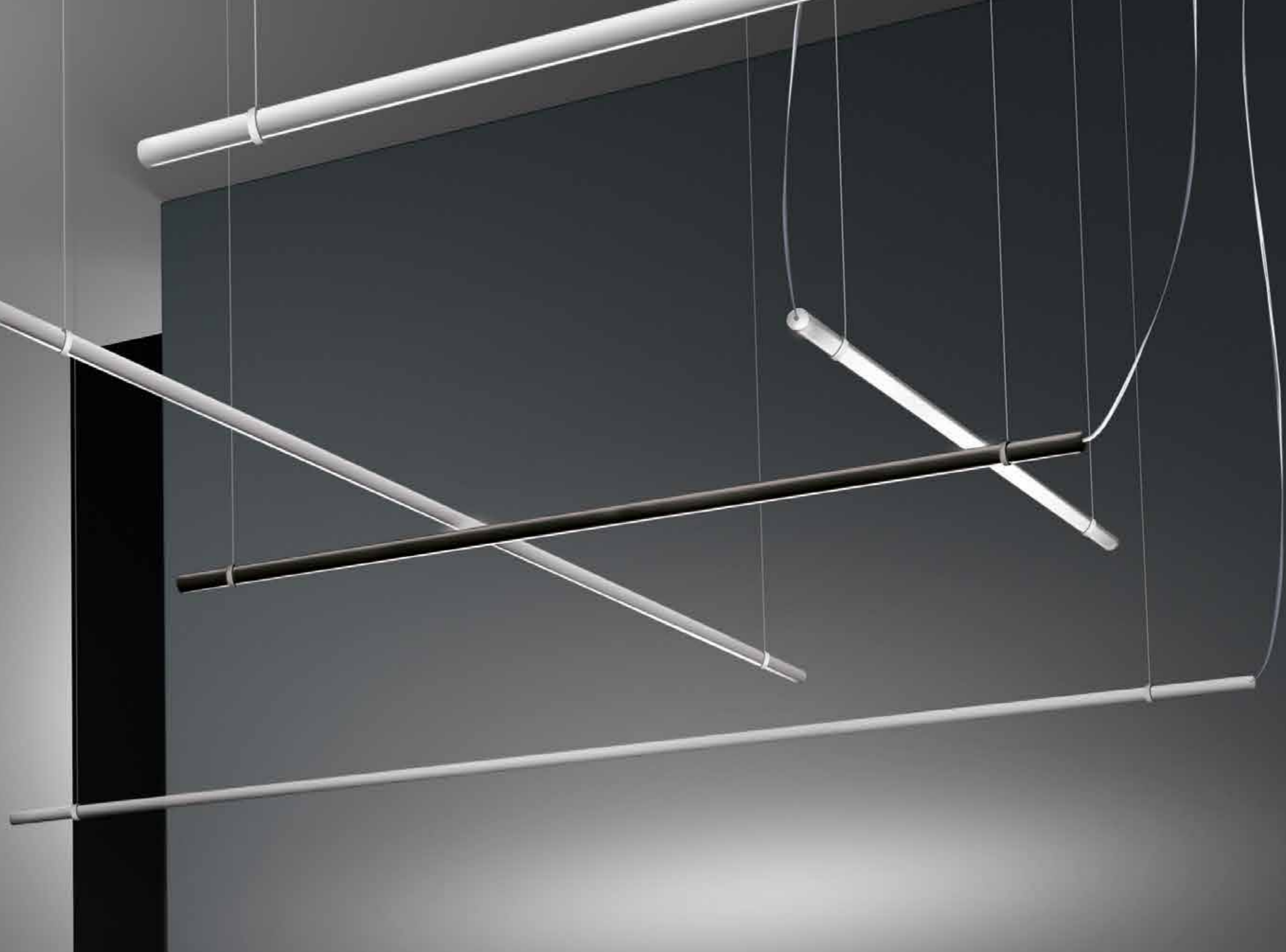

Serie di lampade orientabili a sospensione.
Struttura in alluminio verniciato bianco o nero
diffusore in metacrilato satinato.
Sono realizzabili, a richiesta misure speciali modulari.

Adjustable suspension lamps.
Structure in white or black painted aluminum
and satin methacrylate diffuser.
Fixtures are available, upon request, in modular
special lengths.

Lampe réglable à suspension.
Structure en aluminium laqué blanc ou noire et
diffuseur en méthacrylate satiné.
La version lampadaire est doué d'une patère
Sont disponibles, sur requête, dans des longueurs
modulaires spéciaux.

Serie von Pendeleuchten.
Struktur aus weiß oder schwarz lackiertem Aluminium
und Diffusor aus satiniertem Acrylglas.
Lieferbar auf Anfrage, auch in modularen Sonderlängen
lieferbar.

Serie de colgantes ajustables.
Estructura de aluminio pintado blanco o negro
y difusor de metacrilato satinado.
Disponibles, previa solicitud, en medidas
modulares especiales.

Серия настенных, подвесных или напольных
поворотных светильников.
Корпус из окрашенного алюминия,
диффузор матовый метакрилат. Подвесные
варианты могут быть исполнены по запросу
в других размерах.



CUSTOM SIZE - Tabella lunghezze disponibili a richiesta. Table of available lengths on request.

cm.	watt	2700K (XW)	lm	3000K (WW)	lm	4000K (W)	lm
100	18W	A1540 * /100/XW	2150	A1540 * /100/WW	2380	A1540 * /100/W	2400
125	22,5W	A1540 * /125/XW	2687	A1540 * /125/WW	2975	A1540 * /125/W	3000
150	27W	A1540 * /150/XW	3228	1540 * /WW ** 3570		A1540 * /150/W	3600
175	31,5W	A1540 * /175/XW	3766	A1540 * /175/WW	4165	A1540 * /175/W	4200
200	36W	A1540 * /200/XW	4304	A1540 * /200/WW	4760	A1540 * /200/W	4800
225	40,5W	A1540 * /225/XW	4842	A1540 * /225/WW	5355	A1540 * /225/W	5400
250	45W	A1540 * /250/XW	5380	A1540 * /250/WW	5950	A1540 * /250/W	6000
275	49,5W	A1540 * /275/XW	5918	A1540 * /275/WW	6545	A1540 * /275/W	6600
300	54W	A1540 * /300/XW	6456	A1540 * /300/WW	7140	A1540 * /300/W	7200

* Finiture - Finishes:

.01 Bianco - White

.02 Nero - Black

** Articolo standard a catalogo - Standard catalogue item

1540 1,5 kg

Led 27W 3570lm 3000K

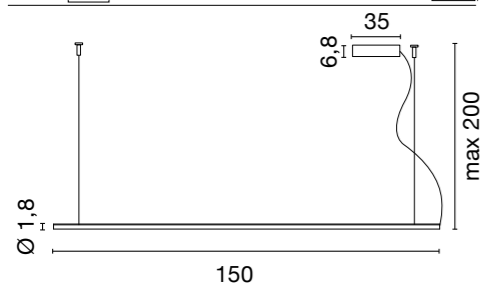
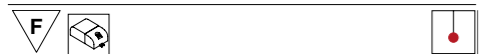

.01/WW .02/WW





Apparecchio lineare a LED con spessore ridotto, particolarmente adatto per installazione sotto pensile e all'interno di mobili. Profilo in estruso d'alluminio anodizzato o verniciato bianco (RAL 9016) con diffusore in policarbonato opalino. Tappi di chiusura in ABS verniciato bianco o grigio. Fissaggio con viti posizionate nei tappi ed eventuale biadesivo (se la lunghezza del pezzo lo richiede). Disponibile in diverse misure (vedi tabelle), tre tonalità di luce (2700, 3000 e 4000K). Gli apparecchi possono essere accessoriati con touch dimmer. Cavo di alimentazione 200 cm.

Lineare LED Leuchte mit reduzierte Dicke besonders geeignet als Unterschrank- oder Möbelbeleuchtung. Profil aus Aluminium eloxiert oder weiß lackiert (RAL 9016) und Diffusor aus opalisiertem Polykarbonat. Endteile aus grau oder weiß lackiertem ABS. Befestigung mit Schrauben in die Endteile, und teilweise, und bei Bedarf mit doppelseitige Klebeband (nur für sehr langen Teilen). Die einzelnen Segmente sind in verschiedene Länge (siehe Tabelle), drei Lichttonen (2700, 3000, 4000K). Ausführungen mit oder Sensordimmer sind auf Anfrage lieferbar. Speisekabellänge 200 cm.

Linear LED fixtures with reduced thickness, suitable for installation under-cabinet or inside pieces of furniture. Extruded aluminum profile in anodized or white finish (RAL 9016) and opal polycarbonate diffuser. End pieces in grey or white painted ABS. Fixing by means of screws positioned in the end pieces and, if needed, with double side adhesive tape (only for very long fixtures). Available in different lengths (see table), three different light tones (2700, 3000 and 4000K). Fixtures can be accessorized with touch dimmer. Supply cable length 200 cm.

Luminarias lineales LED de espesor reducido pensada por instalación bajo mueble o iluminación de armarios. Perfil de aluminio anodizado o pintado blanco (RAL 9016) y difusor de policarbonato opalino. Terminales en ABS pintado gris o blanco. Anclaje con roscas puestas en los terminales y, si es necesarios, con banda adhesiva (solo por elementos muy largos). Los aparatos son disponibles en varias larguras (ver tabla) y tres temperaturas de luz disponibles: 2700, 3000 y 4000K. A pedido se realizan aparatos con toque dimmer. Cable de alimentación 200 cm.

Appareils linéaires LED d'épaisseur réduite spécifique pour installation sous-armoire ou dans des meubles. Profil en aluminium anodisé ou verni blanc (RAL 9016) et diffuseur en polycarbonate opalin. Terminales en ABS verni gris ou blanc. Fixage par des vis situé dans les terminales et, quand nécessaire, avec adhésive double face (seulement pour appareils très longues). Les appareils sont disponibles en différentes longueurs (voir table), trois tonalité de lumière (2700, 3000 et 4000K), et peuvent être accessoirisé avec dimmer touch. Longueur câble d'alimentation 200 cm.

Линейный светильник уменьшенной толщины, подходит для подсветки рабочих поверхностей и установки в мебель. Профиль из экструдированного алюминия окрашен в белый цвет (RAL 9016), опаловый рассеиватель из поликарбоната. Заглушки окрашены в серый или белый цвет. Крепление с помощью винтов, расположенных на концах светильника или с помощью двусторонней самоклеящейся ленты (в случае длинных светильников). Выпускается в различных стандартных длинах (см. таблицу), трех цветовых температурах (2700, 3000 и 4000K). Может быть оснащен датчиком движения или диммером. Поставляется с кабелем длиной 200 см.



CUSTOM SIZE

Tabella lunghezze disponibili. Le misure si riferiscono alle lunghezze totali delle lampade.
Table of available lengths. Measures are referred to complete fixtures including closing heads.

cm.	watt	2700K (XW)	lm	3000K (WW)	lm	4000K (W)	lm
15	1W	A4515 * /10/XW	96	A4515 * /10/WW	102	A4515 * /10/W	108
25	1,9W	A4515 * /20/XW	192	A4515 * /20/WW	204	A4515 * /20/W	216
35	2,9W	A4515 * /30/XW	288	A4515 * /30/WW	306	A4515 * /30/W	324
45	3,8W	A4515 * /40/XW	384	A4515 * /40/WW	408	A4515 * /40/W	432
55	4,8W	A4515 * /50/XW	480	A4515 * /50/WW	510	A4515 * /50/W	540
65	5,8W	A4515 * /60/XW	576	A4515 * /60/WW	612	A4515 * /60/W	648
75	6,7W	A4515 * /70/XW	672	A4515 * /70/WW	714	A4515 * /70/W	756
85	7,7W	A4515 * /80/XW	768	A4515 * /80/WW	816	A4515 * /80/W	864
95	8,6W	A4515 * /90/XW	864	A4515 * /90/WW	918	A4515 * /90/W	972
105	9,6W	A4515 * /100/XW	960	4515 * /WW **	1020	A4515 * /100/W	1080
115	10,6W	A4515 * /110/XW	1056	A4515 * /110/WW	1122	A4515 * /110/W	1188
125	11,5W	A4515 * /120/XW	1152	A4515 * /120/WW	1224	A4515 * /120/W	1296
135	12,5W	A4515 * /130/XW	1248	A4515 * /130/WW	1326	A4515 * /130/W	1404
145	13,4W	A4515 * /140/XW	1344	A4515 * /140/WW	1428	A4515 * /140/W	1512
155	14,4W	A4515 * /150/XW	1440	A4515 * /150/WW	1530	A4515 * /150/W	1620
165	15,4W	A4515 * /160/XW	1536	A4515 * /160/WW	1632	A4515 * /160/W	1728
175	16,3W	A4515 * /170/XW	1632	A4515 * /170/WW	1734	A4515 * /170/W	1836
185	17,3W	A4515 * /180/XW	1728	A4515 * /180/WW	1836	A4515 * /180/W	1944
195	18,2W	A4515 * /190/XW	1824	A4515 * /190/WW	1938	A4515 * /190/W	2052
205	19,2W	A4515 * /200/XW	1920	A4515 * /200/WW	2040	A4515 * /200/W	2160
215	20,2W	A4515 * /210/XW	2016	A4515 * /210/WW	2142	A4515 * /210/W	2268
225	21,1W	A4515 * /220/XW	2112	A4515 * /220/WW	2244	A4515 * /220/W	2376
235	22,1W	A4515 * /230/XW	2208	A4515 * /230/WW	2346	A4515 * /230/W	2484
245	23W	A4515 * /240/XW	2304	A4515 * /240/WW	2448	A4515 * /240/W	2592
255	24W	A4515 * /250/XW	2400	A4515 * /250/WW	2550	A4515 * /250/W	2700
265	25W	A4515 * /260/XW	2496	A4515 * /260/WW	2652	A4515 * /260/W	2808
275	25,9W	A4515 * /270/XW	2592	A4515 * /270/WW	2754	A4515 * /270/W	2916
285	26,9W	A4515 * /280/XW	2688	A4515 * /280/WW	2856	A4515 * /280/W	3024
295	27,8W	A4515 * /290/XW	2784	A4515 * /290/WW	2958	A4515 * /290/W	3132
305	28,8W	A4515 * /300/XW	2880	A4515 * /300/WW	3060	A4515 * /300/W	3240

* Finiture - Finishes:

- .01 Bianco - White
- .45 Alluminio anodizzato - Aluminium anodized

** Articolo standard a catalogo - Standard catalogue item

4515 0,15 kg

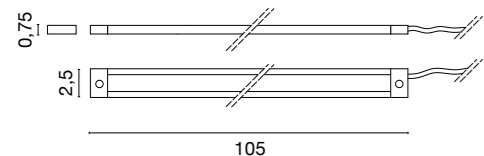

.01/WW .45/WW

Drivers



Optional



0131/S

Interruttore dimmer touch a richiesta.

La lunghezza della lampada rimane invariata, l'interruttore riduce di 10cm la linea di luce.

Touch dimmer switch on request.

The lamp length don't change, touch switch reduces 10cm the light line.

Apparecchi lineari LED, profilo in estruso d'alluminio anodizzato o verniciato bianco RAL 9016 con diffusore in policarbonato opalino.

Idonei per applicazioni angolari sono dotati di staffe di fissaggio a pressione posizionabili ovunque sulla lunghezza del prodotto. Tappi di chiusura in ABS verniciato bianco o grigio. Disponibili in diverse lunghezze (vedi tabella), tre tonalità di luce (2700, 3000 e 4000K) ed RGB.

Gli apparecchi possono essere accessoriati con sensore di movimento o touch dimmer. Cavo di alimentazione 200 cm.

Lineare LED Leuchte. Profil aus Aluminium eloxiert oder weiß lackiert (RAL 9016) und Diffusor aus opalisiertem Polykarbonat. Endteile aus grau oder weiß lackiertem ABS. Besonders geeignet für Eckinstallation die Leuchten sind mit Klick-System Befestigungsteile geliefert, die auf der Rückseite der Profile freilich positioniert werden können. Die einzelnen Segmente sind in verschiedene Länge bestellbar (siehe Tabelle), drei Lichttonen (2700, 3000, 4000K) oder RGB erhältlich.

Ausführungen mit Bewegungserkennung oder Sensordimmer sind auf Anfrage lieferbar. Speisekabellänge 200 cm.

Linear LED fixtures, extruded aluminum profile in anodized or white finish (RAL 9016) and opal polycarbonate diffuser.

Conceived for easy corner installation the product is supplied with click mounting back-plates that can be positioned anywhere on its length. End pieces in grey or white painted ABS.

Available in different lengths (see table), three light tones (2700, 3000 and 4000K) and RGB options.

Fixtures can be accessorized with motion detector switch or touch dimmer. Supply cable length 200 cm.

Luminarias lineales LED. Perfil de aluminio anodizado o pintado blanco (RAL 9016) y difusor de policarbonato opalino. Terminales en ABS pintado gris o blanco.

Pensadas para instalación angular se entregan con soportes de anclaje a presión que se pueden posicionar dondequiera atrás del producto. Los aparatos son disponibles en varias larguras (ver tabla), tres temperaturas de luz (2700, 3000 y 4000K) y RGB.

A pedido se realizan aparatos con con sensor de movimiento o toque dimmer. Cable de alimentación 200 cm.

Appareils linaires LED, profile en aluminium anodisé ou verni blanc (RAL 9016) et diffuseur en polycarbonate opalin. Terminales en ABS verni gris ou blanc.

Adaptés pour installation angulaire sont fournies avec supports de montage a dé clic qui peuvent être fixe n'importe où à l'arrière du produit.

Les appareils sont disponibles en différentes longueurs (voir table), trois tonalités de lumière (2700, 3000 et 4000K), RGB et peuvent être accessorisé avec capteur de mouvement ou dimmer touch.

Longueur câble d'alimentation 200 cm.

Линейный светодиодный светильник. Профиль из экструдированного алюминия окрашен в белый цвет (RAL 9016) с рассеивателем из сатинированного метакрилата.

Предназначен для легкой установки в угол помещения поставляются с зажимами, которые могут крепиться в любом месте с обратной стороны профиля. Заглушки окрашены в серый или белый цвет.

Выпускается в различных стандартных длинах (см. таблицу), трех цветовых температурах (2700, 3000 и 4000K) или RGB.

Может быть оснащен датчиком движения или диммером.

Поставляется с кабелем длиной 200 см.



CUSTOM SIZE

Tabella lunghezze disponibili. Le misure si riferiscono alle lunghezze totali delle lampade.
Table of available lengths. Measures are referred to complete fixtures.

cm.	watt	2700K (XW)	lm	3000K (WW)	lm	4000K (W)	lm	RGB
12,5	1,4W	A4520.45/10/XW	150	A4520.45/10/WW	160	A4520.45/10/W	170	A4520.45/10RGB
22,5	2,9W	A4520.45/20/XW	300	A4520.45/20/WW	320	A4520.45/20/W	340	A4520.45/20RGB
32,5	4,3W	A4520.45/30/XW	450	A4520.45/30/WW	480	A4520.45/30/W	510	A4520.45/30RGB
42,5	5,8W	A4520.45/40/XW	600	A4520.45/40/WW	640	A4520.45/40/W	680	A4520.45/40RGB
52,5	7,2W	A4520.45/50/XW	750	A4520.45/50/WW	800	A4520.45/50/W	850	A4520.45/50RGB
62,5	8,6W	A4520.45/60/XW	900	A4520.45/60/WW	960	A4520.45/60/W	1020	A4520.45/60RGB
72,5	10,1W	A4520.45/70/XW	1050	A4520.45/70/WW	1120	A4520.45/70/W	1190	A4520.45/70RGB
82,5	11,5W	A4520.45/80/XW	1200	A4520.45/80/WW	1280	A4520.45/80/W	1360	A4520.45/80RGB
92,5	13W	A4520.45/90/XW	1350	A4520.45/90/WW	1440	A4520.45/90/W	1530	A4520.45/90RGB
102,5	14,4W	A4520.45/100/XW	1500	A4520.45/WW **	1600	A4520.45/100/W	1700	A4520.45/100RGB
112,5	15,8W	A4520.45/110/XW	1650	A4520.45/110/WW	1760	A4520.45/110/W	1870	A4520.45/110RGB
122,5	17,3W	A4520.45/120/XW	1800	A4520.45/120/WW	1920	A4520.45/120/W	2040	A4520.45/120RGB
132,5	18,7W	A4520.45/130/XW	1950	A4520.45/130/WW	2080	A4520.45/130/W	2210	A4520.45/130RGB
142,5	20,2W	A4520.45/140/XW	2100	A4520.45/140/WW	2240	A4520.45/140/W	2380	A4520.45/140RGB
152,5	21,6W	A4520.45/150/XW	2250	A4520.45/150/WW	2400	A4520.45/150/W	2550	A4520.45/150RGB
162,5	23W	A4520.45/160/XW	2400	A4520.45/160/WW	2560	A4520.45/160/W	2720	A4520.45/160RGB
172,5	24,5W	A4520.45/170/XW	2550	A4520.45/170/WW	2720	A4520.45/170/W	2890	A4520.45/170RGB
182,5	25,9W	A4520.45/180/XW	2700	A4520.45/180/WW	2880	A4520.45/180/W	3060	A4520.45/180RGB
192,5	27,4W	A4520.45/190/XW	2850	A4520.45/190/WW	3040	A4520.45/190/W	3230	A4520.45/190RGB
202,5	28,8W	A4520.45/200/XW	3000	A4520.45/200/WW	3200	A4520.45/200/W	3400	A4520.45/200RGB
212,5	30,2W	A4520.45/210/XW	3150	A4520.45/210/WW	3360	A4520.45/210/W	3570	A4520.45/210RGB
222,5	31,7W	A4520.45/220/XW	3300	A4520.45/220/WW	3520	A4520.45/220/W	3740	A4520.45/220RGB
232,5	33,1W	A4520.45/230/XW	3450	A4520.45/230/WW	3680	A4520.45/230/W	3910	A4520.45/230RGB
242,5	34,6W	A4520.45/240/XW	3600	A4520.45/240/WW	3840	A4520.45/240/W	4080	A4520.45/240RGB
252,5	36W	A4520.45/250/XW	3750	A4520.45/250/WW	4000	A4520.45/250/W	4250	A4520.45/250RGB
262,5	37,4W	A4520.45/260/XW	3900	A4520.45/260/WW	4160	A4520.45/260/W	4420	A4520.45/260RGB
272,5	38,9W	A4520.45/270/XW	4050	A4520.45/270/WW	4320	A4520.45/270/W	4590	A4520.45/270RGB
282,5	40,3W	A4520.45/280/XW	4200	A4520.45/280/WW	4480	A4520.45/280/W	4760	A4520.45/280RGB
292,5	41,8W	A4520.45/290/XW	4350	A4520.45/290/WW	4640	A4520.45/290/W	4930	A4520.45/290RGB
302,5	43,2W	A4520.45/300/XW	4500	A4520.45/300/WW	4800	A4520.45/300/W	5100	A4520.45/300RGB

** Articolo standard a catalogo - Standard catalogue item

4520 0,15 kg

14,4W 24V 3000K

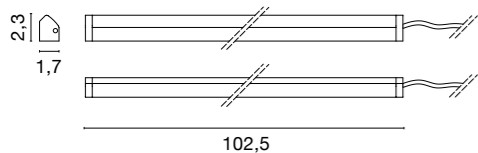
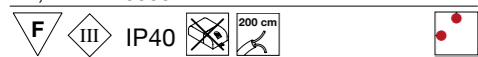

.45/WW

Drivers



Optional



0131/S

Interruttore dimmer touch a richiesta.
La lunghezza della lampada rimane invariata, l'interruttore riduce di 10cm la linea di luce.

Touch dimmer switch on request.

The lamp length don't change, touch switch reduces 10cm the light line.



0131/RV

Sensore di presenza a richiesta.
La lunghezza della lampada rimane invariata, il sensore riduce di 10cm la linea di luce.

Body detector on request.

The lamp length don't change, body detector reduces 10cm the light line.



Apparecchio lineare LED da incasso per applicazioni all'interno di mobili.
 Profilo in estruso d'alluminio anodizzato o verniciato di bianco (RAL 9016), diffusore in policarbonato opalino.
 Tappi di chiusura in ABS verniciato bianco o grigio.
 Disponibile in diverse misure (vedi tabella), tre temperature di colore (2700, 3000 e 4000K).
 Gli apparecchi possono essere accessoriati con sensore di movimento o touch dimmer.
 Cavo di alimentazione 200 cm.

Lineare LED Einbauleuchte für Möbel-beleuchtung.
 Profil aus Aluminium eloxiert oder weiß lackiert (RAL 9016) und Diffusor aus opalisiertem Polykarbonat.
 Endteile aus grau oder weiß lackiertem ABS.
 Die Lichtsegmente sind in verschiedene Länge (siehe Tabelle), drei Lichttonen (2700, 3000, 4000K).
 Ausführungen mit Bewegungserkennung oder Sensordimmer sind auf Anfrage lieferbar.
 Speisekabellänge 200 cm.

Linear LED fixtures, suitable for recessed installation into pieces of furniture.
 Extruded aluminum profile in anodized or white finish (RAL 9016) and opal polycarbonate diffuser.
 End pieces in grey or white painted ABS.
 Available in different lengths (see table), three different light tones (2700, 3000 and 4000).
 Fixtures can be accessorized with motion detector switch or touch dimmer.
 Supply cable length 200 cm.

Luminarias lineales empotrables LED por instalación en muebles.
 Perfil de aluminio anodizado o pintado blanco (RAL 9016) y difusor de policarbonato opalino.
 Terminales en ABS pintado gris o blanco.
 Los aparatos son disponibles en varias larguras (ver tabla), tres temperaturas de luz: (2700, 3000, 4000K).
 A pedido se realizan aparatos con con sensor de movimiento o toque dimmer.
 Cable de alimentación 200 cm.

Appareils linéaires LED encastrables pour installation dans des meubles.
 Profil en aluminium anodisé ou verni blanc (RAL 9016) et diffuseur en polycarbonate opalin.
 Terminales en ABS verni gris ou blanc.
 Les appareils sont disponibles en différentes longueurs (voir table), trois tonalité de lumière (2700, 3000 et 4000K), et peuvent être accessorisés avec capteur de mouvement ou dimmer touch.
 Longueur câble d'alimentation 200 cm.

Линейный светодиодный светильник встраиваемый в мебель.
 Профиль из экструдированного алюминия окрашен в белый цвет (RAL 9016), опаловый рассеиватель из поликарбоната. Заглушки окрашены в серый или белый цвет.
 Выпускается в различных стандартных длинах (см. таблицу), трех цветовых температурах (2700, 3000, 4000K).
 Может быть оснащен датчиком движения или диммером.
 Поставляется с кабелем длиной 200 см.



CUSTOM SIZE

Tabella lunghezze disponibili. Le misure si riferiscono alle lunghezze totali delle lampade complete di tappi.
Table of available lengths. Measures are referred to complete fixtures including closing heads.

cm.	watt	cm.	2700K (XW)	lm	3000K (WW)	lm	4000K (W)	lm
14,5	1W	13,5x1,8	A6661 * /10/XW	96	A6661 * /10/WW	102	A6661 * /10/W	108
24,5	1,9W	23,5x1,8	A6661 * /20/XW	192	A6661 * /20/WW	204	A6661 * /20/W	216
34,5	2,9W	33,5x1,8	A6661 * /30/XW	288	A6661 * /30/WW	306	A6661 * /30/W	324
44,5	3,8W	43,5x1,8	A6661 * /40/XW	384	A6661 * /40/WW	408	A6661 * /40/W	432
54,5	4,8W	53,5x1,8	A6661 * /50/XW	480	A6661 * /50/WW	510	A6661 * /50/W	540
64,5	5,8W	63,5x1,8	A6661 * /60/XW	576	A6661 * /60/WW	612	A6661 * /60/W	648
74,5	6,7W	73,5x1,8	A6661 * /70/XW	672	A6661 * /70/WW	714	A6661 * /70/W	756
84,5	7,7W	83,5x1,8	A6661 * /80/XW	768	A6661 * /80/WW	816	A6661 * /80/W	864
94,5	8,6W	93,5x1,8	A6661 * /90/XW	864	A6661 * /90/WW	918	A6661 * /90/W	972
104,5	9,6W	103,5x1,8	A6661 * /100/XW	960	6661 * / WW**	1020	A6661 * /100/W	1080
114,5	10,6W	113,5x1,8	A6661 * /110/XW	1056	A6661 * /110/WW	1122	A6661 * /110/W	1188
124,5	11,5W	123,5x1,8	A6661 * /120/XW	1152	A6661 * /120/WW	1224	A6661 * /120/W	1296
134,5	12,5W	133,5x1,8	A6661 * /130/XW	1248	A6661 * /130/WW	1326	A6661 * /130/W	1404
144,5	13,4W	143,5x1,8	A6661 * /140/XW	1344	A6661 * /140/WW	1428	A6661 * /140/W	1512
154,5	14,4W	153,5x1,8	A6661 * /150/XW	1440	A6661 * /150/WW	1530	A6661 * /150/W	1620
164,5	15,4W	163,5x1,8	A6661 * /160/XW	1536	A6661 * /160/WW	1632	A6661 * /160/W	1728
174,5	16,3W	173,5x1,8	A6661 * /170/XW	1632	A6661 * /170/WW	1734	A6661 * /170/W	1836
184,5	17,3W	183,5x1,8	A6661 * /180/XW	1728	A6661 * /180/WW	1836	A6661 * /180/W	1944
194,5	18,2W	193,5x1,8	A6661 * /190/XW	1824	A6661 * /190/WW	1938	A6661 * /190/W	2052
204,5	19,2W	203,5x1,8	A6661 * /200/XW	1920	A6661 * /200/WW	2040	A6661 * /200/W	2160
214,5	20,2W	213,5x1,8	A6661 * /210/XW	2016	A6661 * /210/WW	2142	A6661 * /210/W	2268
224,5	21,1W	223,5x1,8	A6661 * /220/XW	2112	A6661 * /220/WW	2244	A6661 * /220/W	2376
234,5	22,1W	233,5x1,8	A6661 * /230/XW	2208	A6661 * /230/WW	2346	A6661 * /230/W	2484
244,5	23W	243,5x1,8	A6661 * /240/XW	2304	A6661 * /240/WW	2448	A6661 * /240/W	2592
254,5	24W	253,5x1,8	A6661 * /250/XW	2400	A6661 * /250/WW	2550	A6661 * /250/W	2700
264,5	25W	263,5x1,8	A6661 * /260/XW	2496	A6661 * /260/WW	2652	A6661 * /260/W	2808
274,5	25,9W	273,5x1,8	A6661 * /270/XW	2592	A6661 * /270/WW	2754	A6661 * /270/W	2916
284,5	26,9W	283,5x1,8	A6661 * /280/XW	2688	A6661 * /280/WW	2856	A6661 * /280/W	3024
294,5	27,8W	293,5x1,8	A6661 * /290/XW	2784	A6661 * /290/WW	2958	A6661 * /290/W	3132
304,5	28,8W	303,5x1,8	A6661 * /300/XW	2880	A6661 * /300/WW	3060	A6661 * /300/W	3240

* Finiture - Finishes:

- .01 Bianco - White
- .45 Alluminio anodizzato - Aluminium anodized

** Articolo standard a catalogo - Standard catalogue item

6661 0,15 kg

9,6W 24V 3000K

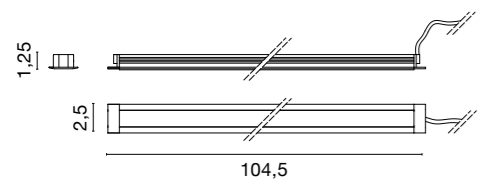
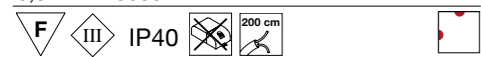

.01/WW .45/WW 1,8 x 103,5

Drivers



Optional



0131/S

Interruttore dimmer touch a richiesta.

La lunghezza della lampada rimane invariata, l'interruttore riduce di 10cm la linea di luce.

Touch dimmer switch on request.

The lamp length don't change, touch switch reduces 10cm the light line.



0131/RV

Sensore di presenza a richiesta.

La lunghezza della lampada rimane invariata, il sensore riduce di 10cm la linea di luce.

Body detector on request.

The lamp length don't change, body detector reduces 10cm the light line.





Apparecchio lineare LED per applicazioni all'interno di mobili.
Profilo in estruso d'alluminio anodizzato, diffusore in policarbonato opalino.

Tappi di chiusura in ABS verniciato grigio.
Disponibile in diverse misure (vedi tabelle), tre temperature di colore (2700, 3000 e 4000K) e versioni RGB.

Gli apparecchi possono essere accessoriati con sensore di movimento o touch dimmer.
Cavo di alimentazione 200 cm.

Linear LED fixtures, suitable for installation into pieces of furniture.
Extruded aluminum profile in anodized. End pieces in grey.

Available in different lengths (see table), three different light tones (2700, 3000 and 4000K) and RGB options.

Fixtures can be accessorized with motion detector switch or touch dimmer.
Supply cable length 200 cm.

Appareils linéaires LED pour installation dans des meubles.

Profil en aluminium anodisé.
Terminales en ABS verni gris.

Les appareils sont disponibles en différentes longueurs (voir table), trois tonalités de lumière (2700, 3000 et 4000K), RGB et peuvent être accessorisés avec capteur de mouvement ou dimmer touch.

Longueur câble d'alimentation 200 cm.

Lineare LED Leuchte für Möbelbeleuchtung.
Profil aus Aluminium eloxiert. Diffusor aus opalisiertem Polykarbonat.

Endteile aus grau lackiertem ABS.

Die Lichtsegmente sind in verschiedene Länge (siehe Tabelle), drei Lichttönen (2700, 3000, 4000K) und RGB erhältlich.

Ausführungen mit Bewegungserkennung oder Sensordimmer sind auf Anfrage lieferbar.
Speisekabellänge 200 cm.

Luminarias lineales LED por instalación en muebles.

Perfil de aluminio anodizado difusor de policarbonato opalino.

Terminales en ABS pintado gris.

Los aparatos son disponibles en varias longitudes (ver tabla), tres temperaturas de luz: (2700, 3000, 4000K) y RGB.

A pedido se realizan aparatos con con sensor de movimiento o toque dimmer.
Cable de alimentación 200 cm.

Линейный светодиодный светильник встраиваемый в мебель.

Профиль из экструдированного алюминия окрашен, опаловый рассеиватель из поликарбоната. Заглушки окрашены в серый или белый.

Выпускается в различных стандартных длинах (см. таблицу), трех цветовых температурах (2700, 3000, 4000K) и RGB. Может быть оснащен датчиком движения или диммером.

Поставляется с кабелем длиной 200 см.



CUSTOM SIZE

Tabella lunghezze disponibili. Le misure si riferiscono alle lunghezze totali delle lampade senza squadrette orientabili.
 Per montaggio con squadrette orientabili aggiungere 2 cm.
 Table of available lengths. Measures are referred to complete fixtures excluding fixing supports
 To install using fixing supports add 2 cm more.

cm.	watt	2700K (XW)	lm	3000K (WW)	lm	4000K (W)	lm	RGB
13	1,4W	A4522.45/10/XW	150	A4522.45/10/WW	160	A4522.45/10/W	170	A4522.45/10RGB
23	2,9W	A4522.45/20/XW	300	A4522.45/20/WW	320	A4522.45/20/W	340	A4522.45/20RGB
33	4,3W	A4522.45/30/XW	450	A4522.45/30/WW	480	A4522.45/30/W	510	A4522.45/30RGB
43	5,8W	A4522.45/40/XW	600	A4522.45/40/WW	640	A4522.45/40/W	680	A4522.45/40RGB
53	7,2W	A4522.45/50/XW	750	4522.45 ★★	800	A4522.45/50/W	850	A4522.45/50RGB
63	8,6W	A4522.45/60/XW	900	A4522.45/60/WW	960	A4522.45/60/W	1020	A4522.45/60RGB
73	10,1W	A4522.45/70/XW	1050	A4522.45/70/WW	1120	A4522.45/70/W	1190	A4522.45/70RGB
83	11,5W	A4522.45/80/XW	1200	4523.45 ★★	1280	A4522.45/80/W	1360	A4522.45/80RGB
93	13W	A4522.45/90/XW	1350	A4522.45/90/WW	1440	A4522.45/90/W	1530	A4522.45/90RGB
103	14,4W	A4522.45/100/XW	1500	A4522.45/100/WW	1600	A4522.45/100/W	1700	A4522.45/100RGB
113	15,8W	A4522.45/110/XW	1650	A4522.45/110/WW	1760	A4522.45/110/W	1870	A4522.45/110RGB
123	17,3W	A4522.45/120/XW	1800	A4522.45/120/WW	1920	A4522.45/120/W	2040	A4522.45/120RGB
133	18,7W	A4522.45/130/XW	1950	A4522.45/130/WW	2080	A4522.45/130/W	2210	A4522.45/130RGB
143	20,2W	A4522.45/140/XW	2100	A4522.45/140/WW	2240	A4522.45/140/W	2380	A4522.45/140RGB
153	21,6W	A4522.45/150/XW	2250	A4522.45/150/WW	2400	A4522.45/150/W	2550	A4522.45/150RGB
163	23W	A4522.45/160/XW	2400	A4522.45/160/WW	2560	A4522.45/160/W	2720	A4522.45/160RGB
173	24,5W	A4522.45/170/XW	2550	A4522.45/170/WW	2720	A4522.45/170/W	2890	A4522.45/170RGB
183	25,9W	A4522.45/180/XW	2700	A4522.45/180/WW	2880	A4522.45/180/W	3060	A4522.45/180RGB
193	27,4W	A4522.45/190/XW	2850	A4522.45/190/WW	3040	A4522.45/190/W	3230	A4522.45/190RGB
203	28,8W	A4522.45/200/XW	3000	A4522.45/200/WW	3200	A4522.45/200/W	3400	A4522.45/200RGB
213	30,2W	A4522.45/210/XW	3150	A4522.45/210/WW	3360	A4522.45/210/W	3570	A4522.45/210RGB
223	31,7W	A4522.45/220/XW	3300	A4522.45/220/WW	3520	A4522.45/220/W	3740	A4522.45/220RGB
233	33,1W	A4522.45/230/XW	3450	A4522.45/230/WW	3680	A4522.45/230/W	3910	A4522.45/230RGB
243	34,6W	A4522.45/240/XW	3600	A4522.45/240/WW	3840	A4522.45/240/W	4080	A4522.45/240RGB
253	36W	A4522.45/250/XW	3750	A4522.45/250/WW	4000	A4522.45/250/W	4250	A4522.45/250RGB
263	37,4W	A4522.45/260/XW	3900	A4522.45/260/WW	4160	A4522.45/260/W	4420	A4522.45/260RGB
273	38,9W	A4522.45/270/XW	4050	A4522.45/270/WW	4320	A4522.45/270/W	4590	A4522.45/270RGB
283	40,3W	A4522.45/280/XW	4200	A4522.45/280/WW	4480	A4522.45/280/W	4760	A4522.45/280RGB
293	41,8W	A4522.45/290/XW	4350	A4522.45/290/WW	4640	A4522.45/290/W	4930	A4522.45/290RGB
303	43,2W	A4522.45/300/XW	4500	A4522.45/300/WW	4800	A4522.45/300/W	5100	A4522.45/300RGB

★★ Articolo standard a catalogo - Standard catalogue item

4522 0,15 kg

7,2W 24V 3000K

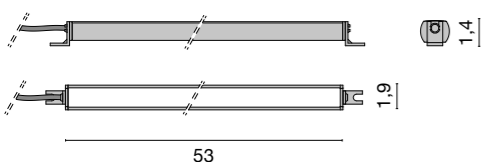
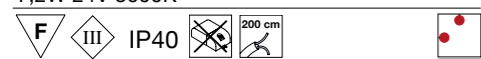

.45

4523 0,2 kg

11,5W 24V 3000K

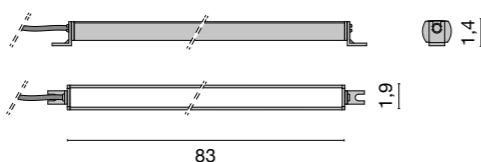

.45

Drivers



Optional



0131/S
Interruttore dimmer touch a richiesta.
 La lunghezza della lampada rimane invariata, l'interruttore riduce di 10cm la linea di luce.
Touch dimmer switch on request.
 The lamp length don't change, touch switch reduces 10cm the light line.



0131/RV
Sensore di presenza a richiesta.
 La lunghezza della lampada rimane invariata, il sensore riduce di 10cm la linea di luce.
Body detector on request.
 The lamp length don't change, body detector reduces 10cm the light line.





Circuiti flessibili LED IP20 o IP65 (con guaina in silicone) 24V 14,4W/m (rolla 4mt). Realizzati con LED 5630 di ultima generazione montati su supporto in Kapton® garantiscono omogeneità di colore ed un flusso costante nel tempo. Ordinabile al metro, eccetto 5552 (vedi codici tabella) il prodotto è sezionabile ogni 10 cm. Disponibile in tre diverse temperature di colore: 2700, 3000, 4000K. Standard CRI>85, a richiesta CRI> 90. Può essere utilizzata con drivers dimmerabili o kit emergenza (vedi tabella). Al fine di assicurare un'adeguata dissipazione si consiglia vivamente l'utilizzo del profilo accessorio 0244.

LED flexible circuit IP20 or IP65 (with silicon cover), 24V 14,4W/m (4mt rolls). Produced with latest generation LED 5630 mounted on Kapton® film grants uniform binning and constant lumen output over time. The product can be ordered by meter, except 5552 (see table) and can be cut every 10 cm. Available in three light tones: 2700, 3000 or 4000K. Standard CRI>85, upon request CRI>90. It can be accessorized with dimmable drivers or emergency light kit(see table). In order to ensure an adequate heat dissipation we strongly recommend the use of profile accessory 0244.

Circuit flexible LED IP20 ou IP65 (recouvert en silicone), 24V 14,4W/m (Ruban 4mt). Le circuit utilise des LED 5630 de dernière génération monté sur film en Kapton® pour garantir une tonalité de lumière homogène et un flux lumineux constant dans le temps. Le produit peut être commande par mètre, sauf 5552 (voir table). Possibilité de découpage chaque 10 cm. Correspondence couleur standard CRI>85, sur requete CRI>90. Peut être utilisé aussi avec convertisseur dimmable ou kit lumière de secours. Afin d'assurer une dissipation de chaleur efficace c'est fortement conseillé l'usage de l'accessoire profile 0244.

Flexibel LED Schaltung IP20 oder IP65 (mit Silikon-Isolation) 24V 14,4W/m (4m Rolle). Hergestellt mit LED 5630 der neueste Generation montiert auf Kapton® Streife das Produkt garantiert homogene Lichtfarbe und konstante Lichtausbeute. Verkäuflich pro Meter, außer 5552 (Sieh Tabelle) das Produkt ist alle 10 cm trennbar. Verfügbar in drei Lichttonen: 2700, 3000, 4000K. Standard Farbwiedergabe: CRI>85, auf Anfrage CRI>90. Das Produkt kann auch mit dimmbarer-Konverter oder Notbeleuchtung Kit benutzt werden. Um die optimale Kühlung zu gewährleisten, ist die Benutzung der Profil stark empfohlen (Zubehör 0244).

Circuitos flexibles LED IP20 o IP65 (cobertura de silicones) 24V 14,4W/m (Rollo de 4 m). Producidos con LED 5630 de última generación colocados sobre soporte en Kapton® aseguran un tono de luz homogéneo y un flujo luminoso que permanece constante en el tiempo. El producto se vende también por metro, excepto 5552 (ver tabla) y se puede cortar cada 10 cm. Tres tonos de luz disponibles: 2700, 3000, 4000K. Convertidores on-off o con dimmer, luz de emergencia se piden por separado. Índice de reproducción cromática estandar CRI>85, a pedido CRI>90. Para garantizar una buena disipación de calor se aconseja fuertemente que se utilice el perfil metálico (acesorio 0244).

Светодиодная лента IP20 или IP65 (силиконовый рассеиватель), 24В, 14,4 В/м (катушки по 4 м). Используются светодиоды 5630 последнего поколения, обеспечивающие однородный свет и постоянство светотдачи с течением времени. Может быть заказан с кратностью до метра, кроме 5552 (см. таблицу) или с шагом 10 см. Цветовая температура: 2700, 3000 или 4000К. Стандартно CRI>85, по запросу - CRI>90. В качестве аксессуаров может быть диммируемый драйвер и аварийный блок питания (см. таблицу) Для правильного теплоотвода рекомендуется использовать профиль 0244.



5511 astra

14,4 W/mt 24V

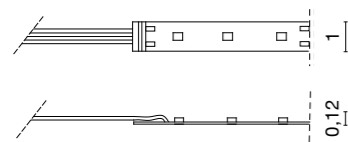

.01

cm	Source LED cod.	W	lm/mt	LED color
/100	/XW	14,4W	1500lm	2700K
/100	/WW	14,4W	1600lm	3000K
/100	/W	14,4W	1700lm	4000K
<hr/>				
/200	/XW	28,8W	3000lm	2700K
/200	/WW	28,8W	3200lm	3000K
/200	/W	28,8W	3400lm	4000K
<hr/>				
/300	/XW	43,2W	4500lm	2700K
/300	/WW	43,2W	4800lm	3000K
/300	/W	43,2W	5100lm	4000K
<hr/>				
/400	/XW	57,6W	6000lm	2700K
/400	/WW	57,6W	6400lm	3000K
/400	/W	57,6W	6800lm	4000K

Accessories



Drivers



5551 astra IP

14,4 W/mt 24V

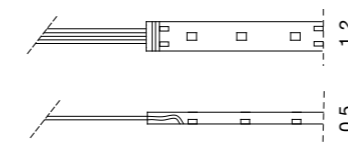

.01

cm	Source LED cod.	W	lm/mt	LED color
/100	/XW	14,4W	1500lm	2700K
/100	/WW	14,4W	1600lm	3000K
/100	/W	14,4W	1700lm	4000K
<hr/>				
/200	/XW	28,8W	3000lm	2700K
/200	/WW	28,8W	3200lm	3000K
/200	/W	28,8W	3400lm	4000K
<hr/>				
/300	/XW	43,2W	4500lm	2700K
/300	/WW	43,2W	4800lm	3000K
/300	/W	43,2W	5100lm	4000K
<hr/>				
/400	/XW	57,6W	6000lm	2700K
/400	/WW	57,6W	6400lm	3000K
/400	/W	57,6W	6800lm	4000K

Accessories



Drivers





5552 astra 120 5 mt.

48W 24V

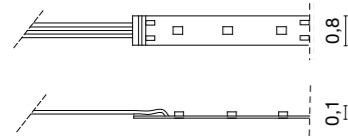

.01/XW .01/WW .01/W

Source LED cod.	lm/mt	LED color
/XW	960lm	2700K
/WW	1020lm	3000K
/W	1080lm	4000K

Accessories



0244/100 Profile **0244/200** Profile **0244/300** Profile

Drivers



0156 24V 25W **0160** 24V 50W **0157** 24V 72W **0162** 24V 150W **0161/100** 24V 100W **0110/DIM** Dimmer 24V **0717/DIM60** Dimmer - 60W **0717/DIM100** Dimmer - 100W **0115/EM** Emergency Unit

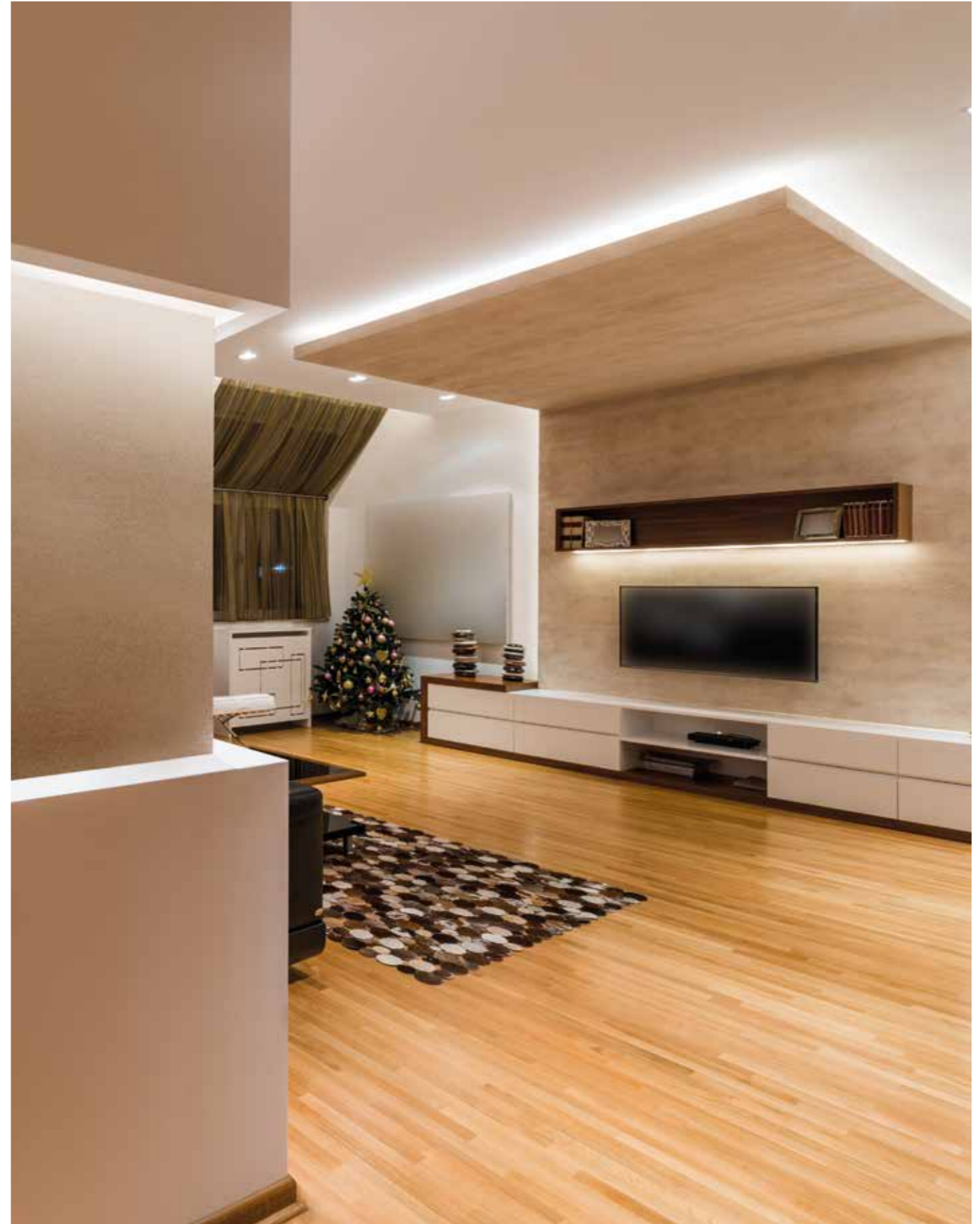



Strisce Led 24V (rolla 5m).
Disponibili in diverse temperature di colore e due potenze (14,4W/mt e 6W/mt) entrambe sezionabili ogni 10 cm.
Può essere utilizzata con drivers dimmerabili o kit emergenza (vedi tabella).

LED strip 24V(5m roll).
Available in different light tones and 2 powers (14,4W/m and 6W/m), both can be cut every 10cm.
The product can be used also with dimmable drivers or emergency kit.

Ruban LED 24V(5m roll).
Disponible dans différentes tonalités de lumière et en deux puissances (14,4W/m et 6W/m), possibilité de découpage chaque 10 cm.
Peux être utilisé aussi avec convertisseur dimmable ou kit lumière de secours.

LED-Streifen 24V(5m Rolle).
Verfügbar in verschiedene Lichttönen und zwei Leistungen (14,4W/m und 6W/m), trennbar alle 10cm.
Das Produkt kann auch mit dimmbarer-Konverter oder Notbeleuchtung Kit benutzt werden.

Tira de LED 24V (rollo 5 m).
Disponible en diferentes tonos de luz y dos potencias (14,4W/m y 6W/m), se pueden cortar cada 10 cm.
El producto se puede utilizar también con con-vertidor dimmable o Kit luz de emergencia.

Светодиодная лента 24 В (катушки по 5 м). Доступна в различных цветовых температурах и двух вариантах мощности (14 Вт/м и 6 Вт/м), кратность 10 см. Может использоваться с диммируемым драйвером или аварийным блоком.

5534 5 mt.

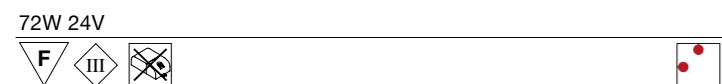

.01/WW .01/W

Source LED cod.	lm/mt	LED color
/WW	1080lm	3000K
/W	1170lm	4000K

Accessories

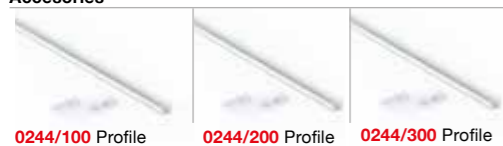

Drivers



5516 5 mt.

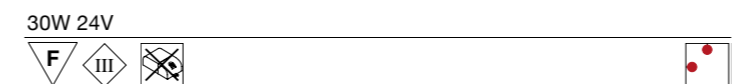

.01/WW .01/W

Source LED cod.	lm/mt	LED color
/WW	360lm	3000K
/W	380lm	4000K

Accessories



Drivers



NEWTON

design: U.T. EgoIuce



Proiettore orientabile da soffitto/parete, corpo in metallo verniciato bianco, nero o cromato. LED COB con vetro trasparente (/TR) o satinato (/ST).

A richiesta sono fornibili anche altre tonalità di luce, 2700K e 4000K, o fasci di apertura (24° e 58°)

Ceiling/wall adjustable spotlight. Metal frame available in white or black painted finish or chromed.

COB LED with transparent (/TR) or satin (/ST) glass.

Other light tones 2700K or 4000K and beam angles (24° - 58°) can be supplied upon request.

Projecteur orientable mur/plafond. Structure en métal verni blanc, noir ou en chromé.

LED COB avec verre transparent (/TR) ou satiné (/ST).

D'autres tonalités de lumière 2700 ou 4000K et faisceaux (24°-58°) sont disponibles sur demande.

Verstellbare Lichtstrahler für Decke- oder Wandbefestigung. Gehäuse aus Metall, Ausführung: schwarz, weiß oder verchromt.

COB Led mit Glasscheibe klar (/TR) oder satiniert (/ST).

Auf Anfrage sind andere Lichttonen 2700 oder 4000K und Abstrahlwinkel (24°-58°) lieferbar.

Proyector orientable para techo/pared. Cuerpo de metal pintado blanco, negro o en acabado cromado.

Led COB con vidrio transparente (/TR) o satinado (/ST).

A pedido se realizan aparatos con otras tonos de luz, 2700y 4000K, y hazes de luz (24°-58°).

Потолочный или настенный прожектор. Корпус из металла, окрашенного в белый и черный цвет алюминии.

Светодиод COB (COB = Chip On Board = светодиоды на плате) с прозрачной (/TR) или матовой (/ST) линзой.

Светильники с другой цветовой температурой 2700К или 4000К и Двумя лучами (24-58 градусов) могут быть.

NEWTON

design: U.T. Ego luce



4562 0,6 kg

ww 9,2W 18,4V 500mA 1056lm CRI>80 3000K^{38°}

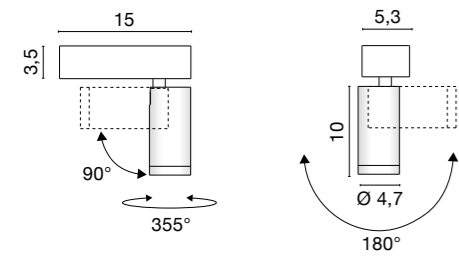

.01/W .02/W .31/W

Options

- /ST** Con vetro satinato - Satin glass
- /TR** Con vetro trasparente - Clear glass



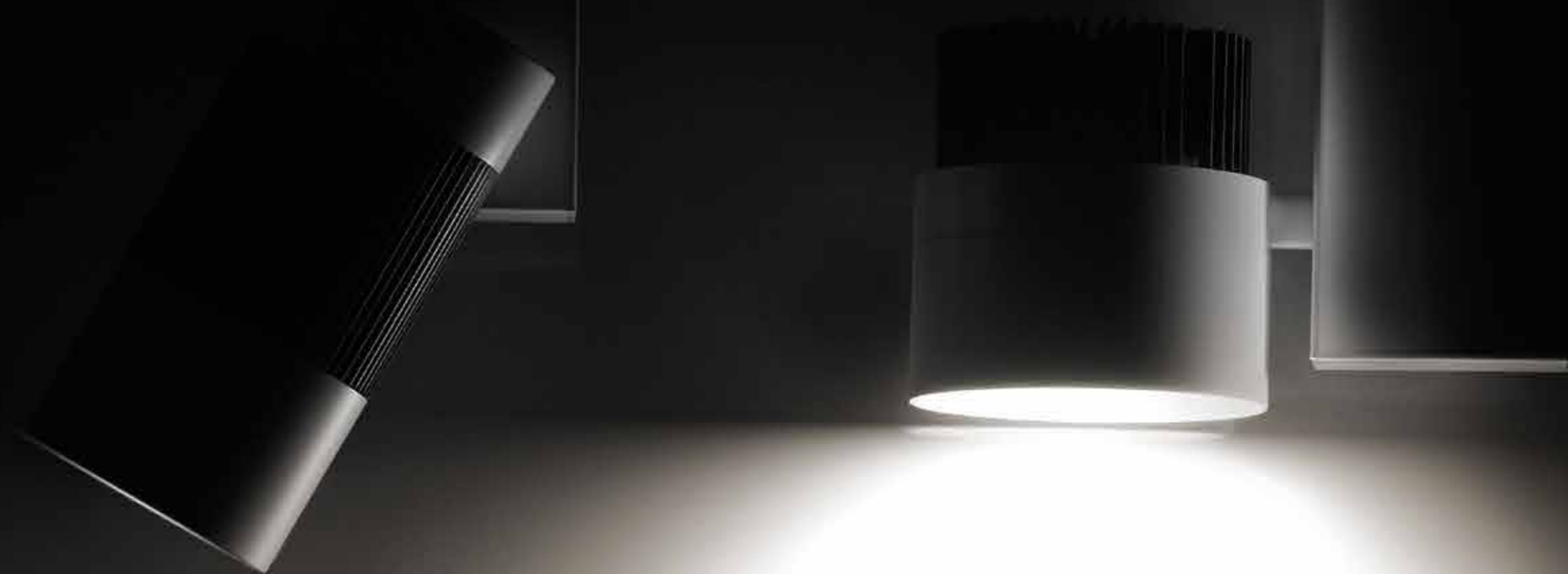

Proiettori orientabili a binario. Struttura in alluminio verniciato bianco-nero. Disponibili in due diverse versioni a Led.

Track adjustable projectors. Frame in painted aluminium in black-and-white finish. Available in two different Led options.

Projecteurs orientables pour rail. Structure en aluminium verni blanc-noir. Disponibles dans deux différentes version LED.

Verstellbare Lichtstrahleren für Stromschiene. Gestell aus Weiß-Schwarz lackiertem Aluminium. Verfügbar in zwei verschiedene LED Ausführungen.

Proyectoros orientables para binario. Cuerpo en aluminio pintado en blanco-negro. Disponibles en dos diferentes versiones LED .

Потолочный или настенный шина. Корпус из алюминия, окрашенного в белый и черный цвет. Имеются 2 варианта исполнения со светодиодами.

GALILEO

design: UT Ego luce



6553		1,6 kg
.01/17/WW	13,8W 27,6V 500mA 1649lm CRI>80 3000K	
.01/17/W	13,8W 27,6V 500mA 1741lm CRI>80 4000K	
.01/37/WW	13,8W 27,6V 500mA 1649lm CRI>80 3000K	
.01/37/W	13,8W 27,6V 500mA 1741lm CRI>80 4000K	

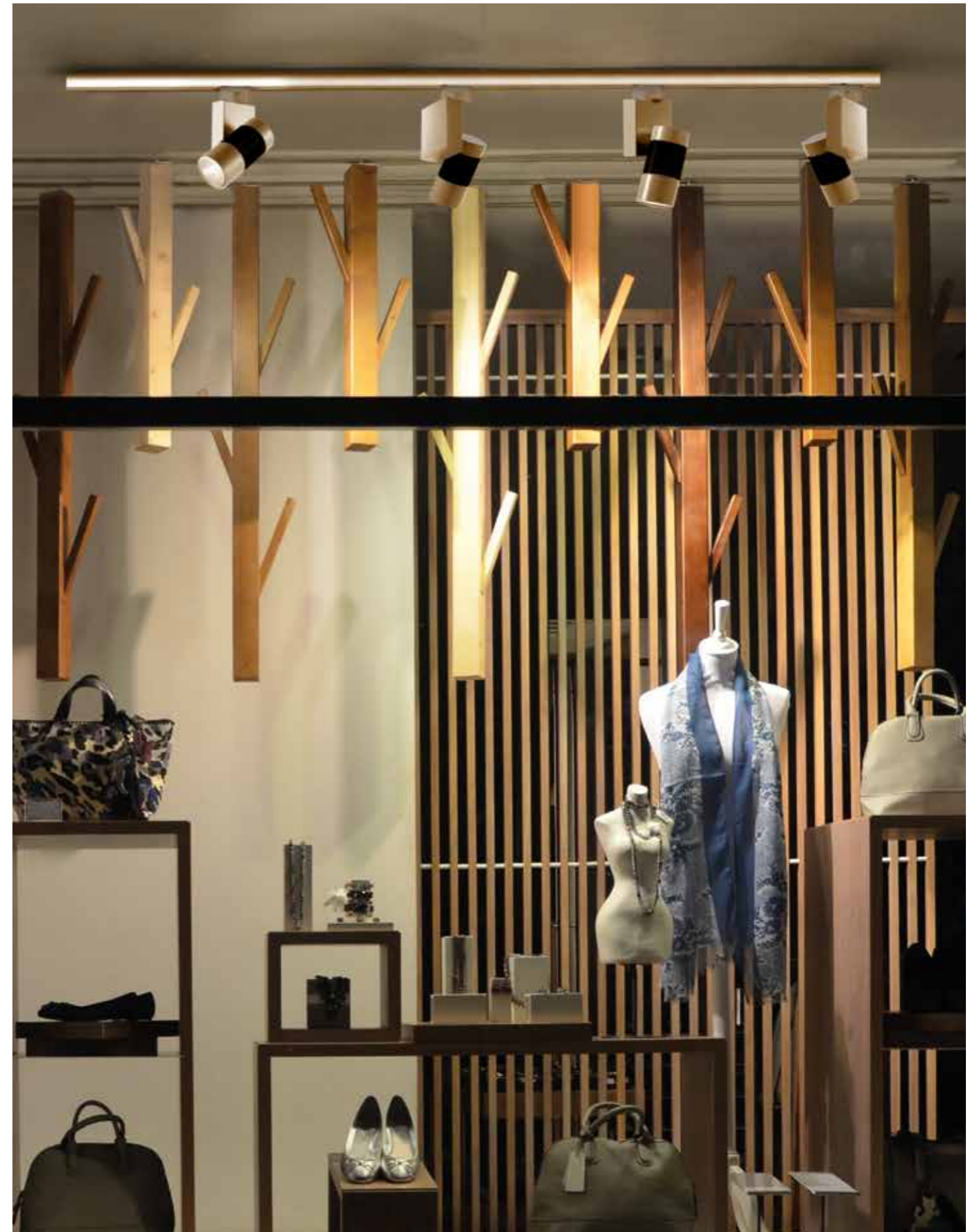
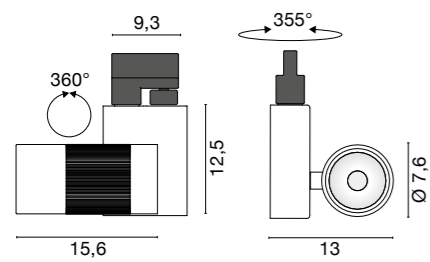

GALILEO MAXI COB

design: U.T. EgoLucé



6555		1,30 kg
.01/12/WW	23,4W 33,7V 700mA 2813lm CRI>80 3000K	
.01/12/W	23,4W 33,7V 700mA 2919lm CRI>80 4000K	
.01/40/WW	23,4W 33,7V 700mA 2813lm CRI>80 3000K	
.01/40/W	23,4W 33,7V 700mA 2919lm CRI>80 4000K	

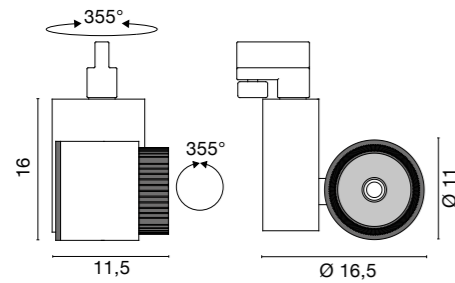



Proiettori orientabili in pressofusione
d'alluminio verniciato.

Adjustable Projectors in painted
Die-cast aluminium body.

Projecteurs orientables en
aluminium injecté vern.

Verstellbare Lichtstrahler aus
Aluminiumdruckguss.

Proyectores orientables en aluminio
moldeado pintado.

Поворотные прожекторы
из окрашенного литого под
давлением алюминия.

COLIBRI' SMALL LED

design: S. Anconetani



6534 1 kg
 7W GU10 LED 600lm
 F

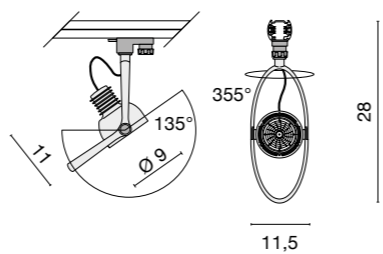

.01/LED .40/LED



6533 1,2 kg
 7W GU10 LED 600lm
 F

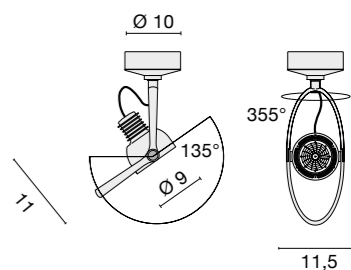

.01/LED .40/LED



COLIBRI' KIT LED

design: S. Anconetani

Lighting Systems



7230

3 x 7W GU10 LED 1800lm

F

4 kg

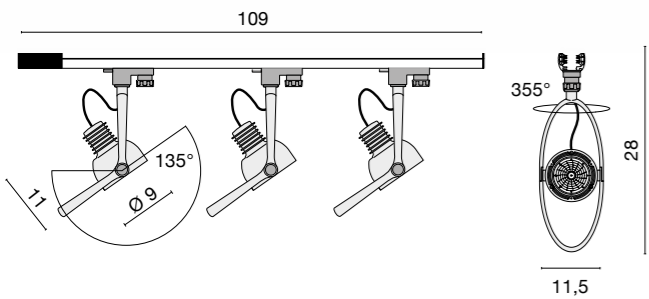

.01/LED

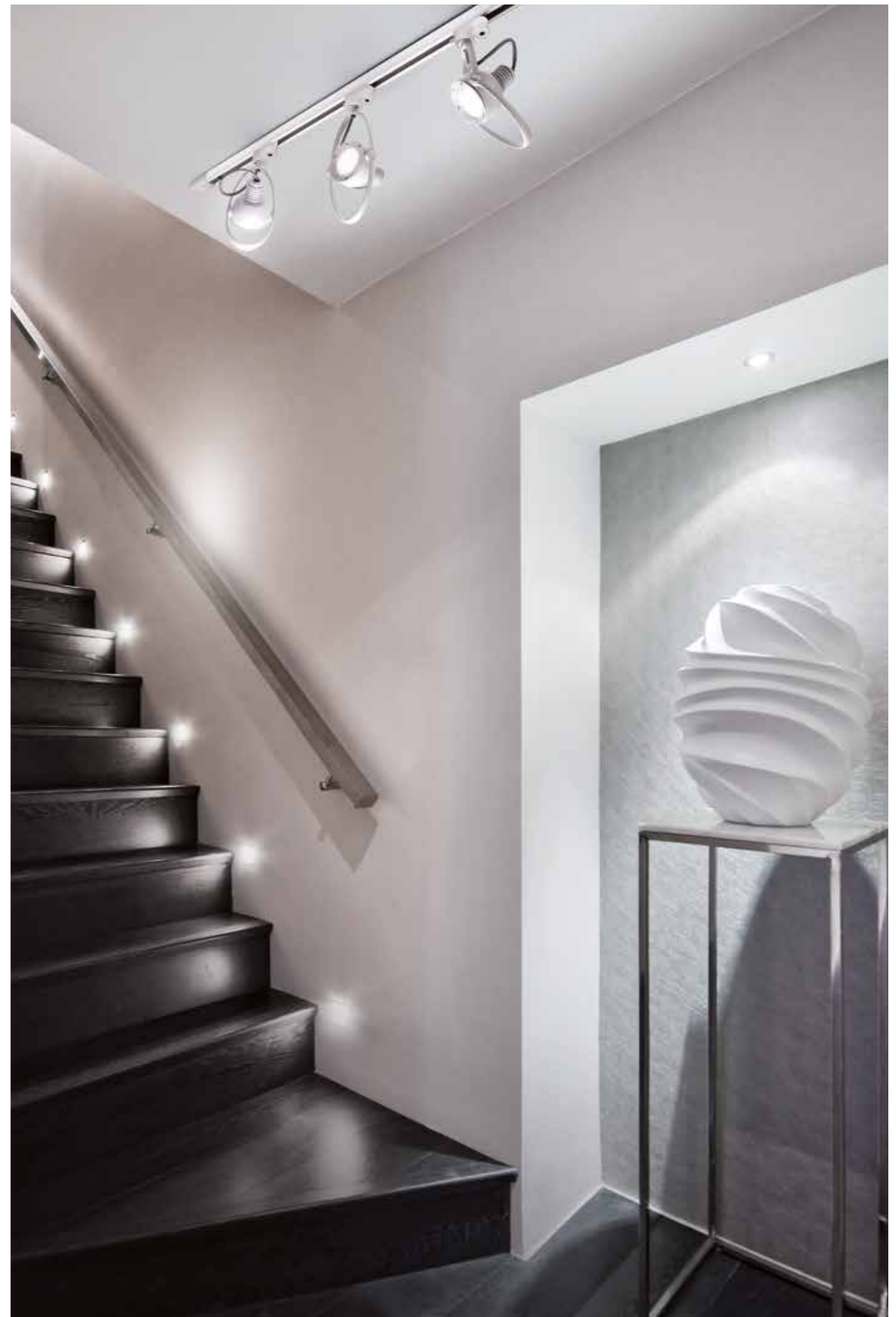

Lighting Systems



Proiettori orientabili. Struttura in alluminio verniciato bianco-nero. Disponibile in due diverse versioni a Led.

Adjustable projectors. Frame in painted aluminium in black-and-white finish. Available in two different Led options.

Projecteurs orientables. Structure en aluminium verni blanc-noir. Disponible dans deux différentes version LED.

Verstellbare Lichtstrahler Gestell aus Weiß-Schwarz lackiertem Aluminium. Verfügbar in zwei verschiedene LED Ausführungen.

Proyectores orientables. Cuerpo en aluminio pintado en blanco-negro. Disponible en dos diferentes versiones LED.

Потолочный или настенный. Корпус из алюминия, окрашенного в белый и черный цвет. Имеются 2 варианта исполнения со светодиодами.



4526 1,5 kg
16W 980lm 3000K

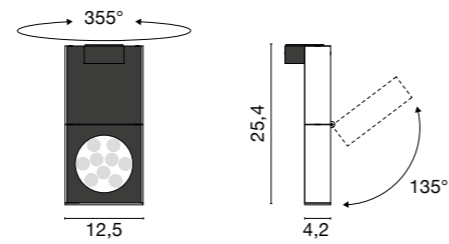

.01



4527 1,7 kg
19W 2470lm 3000K

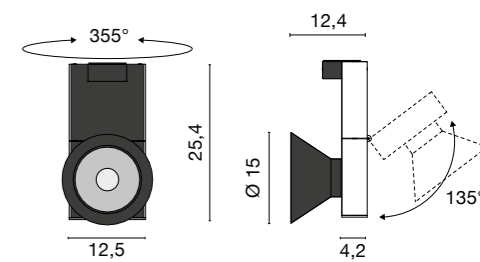

.01/18 .01/41



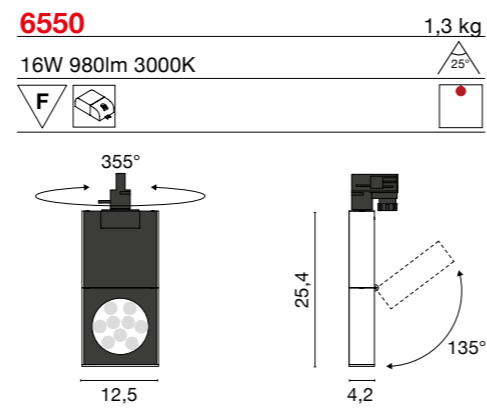

.01

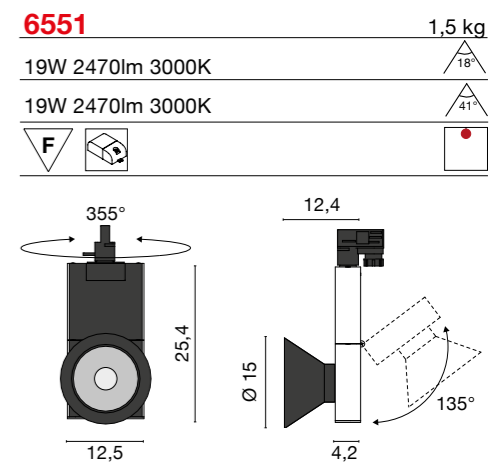

.01/18 .01/41





BINARIO elettrificato a tre accensioni diversificate, costruito in lega di alluminio estruso con conduttori in rame alloggiati all'interno di profilati estrusi in PVC.

Electrified TRACK with 3 different switchings, made in extruded aluminium with internal PVC extrusion copper wires.

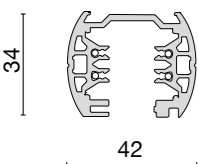

Posizionamento dell'alimentazione dei conduttori di terra
Position of the supply of earth conductors

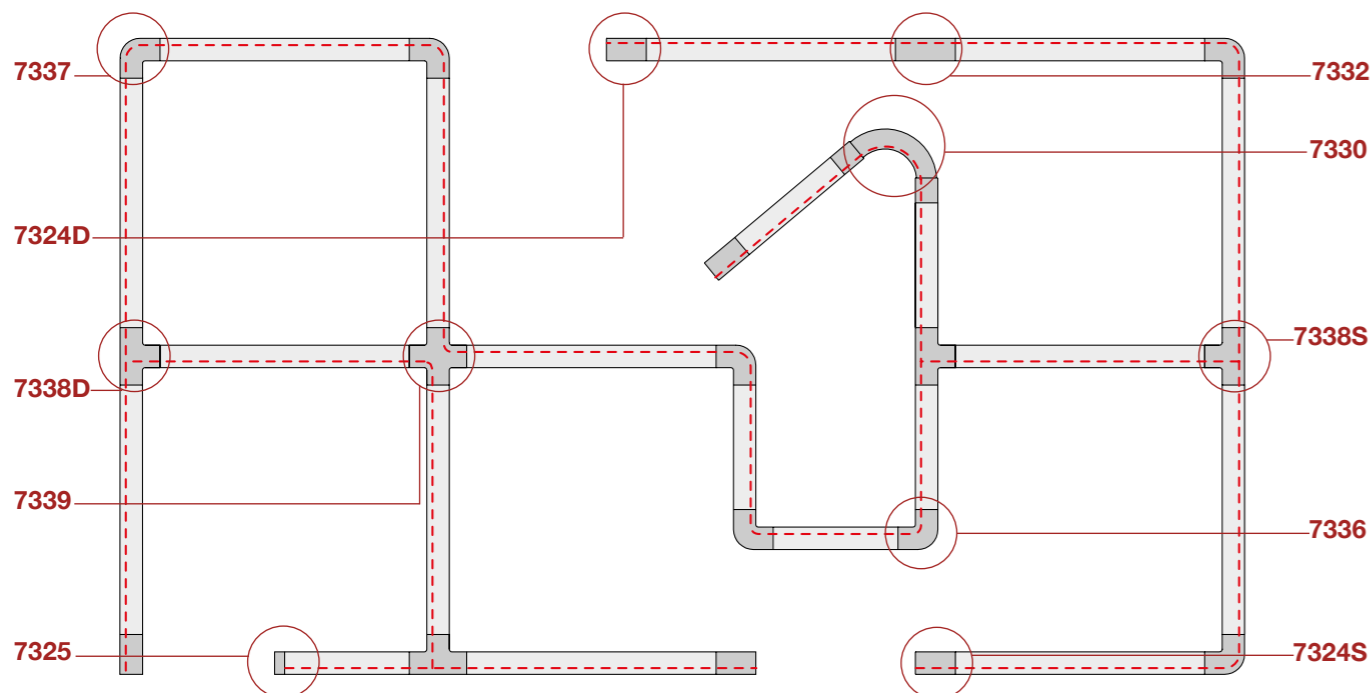

I giunti di collegamento saranno Destro o Sinistro secondo la posizione laterale del contatto di terra.
Joints will be right(D) or left(S) following the lateral position of earth conductors.

7321 3 mt.

250/440V 16A



.01

7322 1 mt.

250/440V 16A



.01

7323 2 mt.

250/440V 16A



.01



7326.01
Adattatore meccanico/elettrico
6A - carico meccanico 5 Kg.
Mechanical/electrical adapters
6A - mechanical load 5 Kg.



7328.01
Giunto lineare.
Straight joint.



7324 D.01
Alimentazione destra.
Right live-end.



7329.01
Giunto lineare senza contatti.
Mechanical joint without contacts.

7324 S.01
Alimentazione sinistra.
Left live-end.



7325.01
Chiusura.
Dead end.



7332.01
Alimentazione centrale e
giunto lineare.
Central connector
with straight joint.



7336.01
Giunto L interno.
Inside L joint.



7333
Piastra 12cm.
Plate 12cm.

7337.01
Giunto L esterno.
Outside L joint.



7339.01
Giunto X.
X joint.



7338 D.01
Giunto T destro.
Right T joint.

7338 S.01
Giunto T sinistro.
Left T joint.



7331.01
Kit per sospensione binario.
Kit to suspend track.

7334.01
Kit cavo acciaio (2m), piastra 6cm.
Kit with steel wire (2m), plate 6cm.



7335
Attacco soffitto kit.
Ceiling kit.

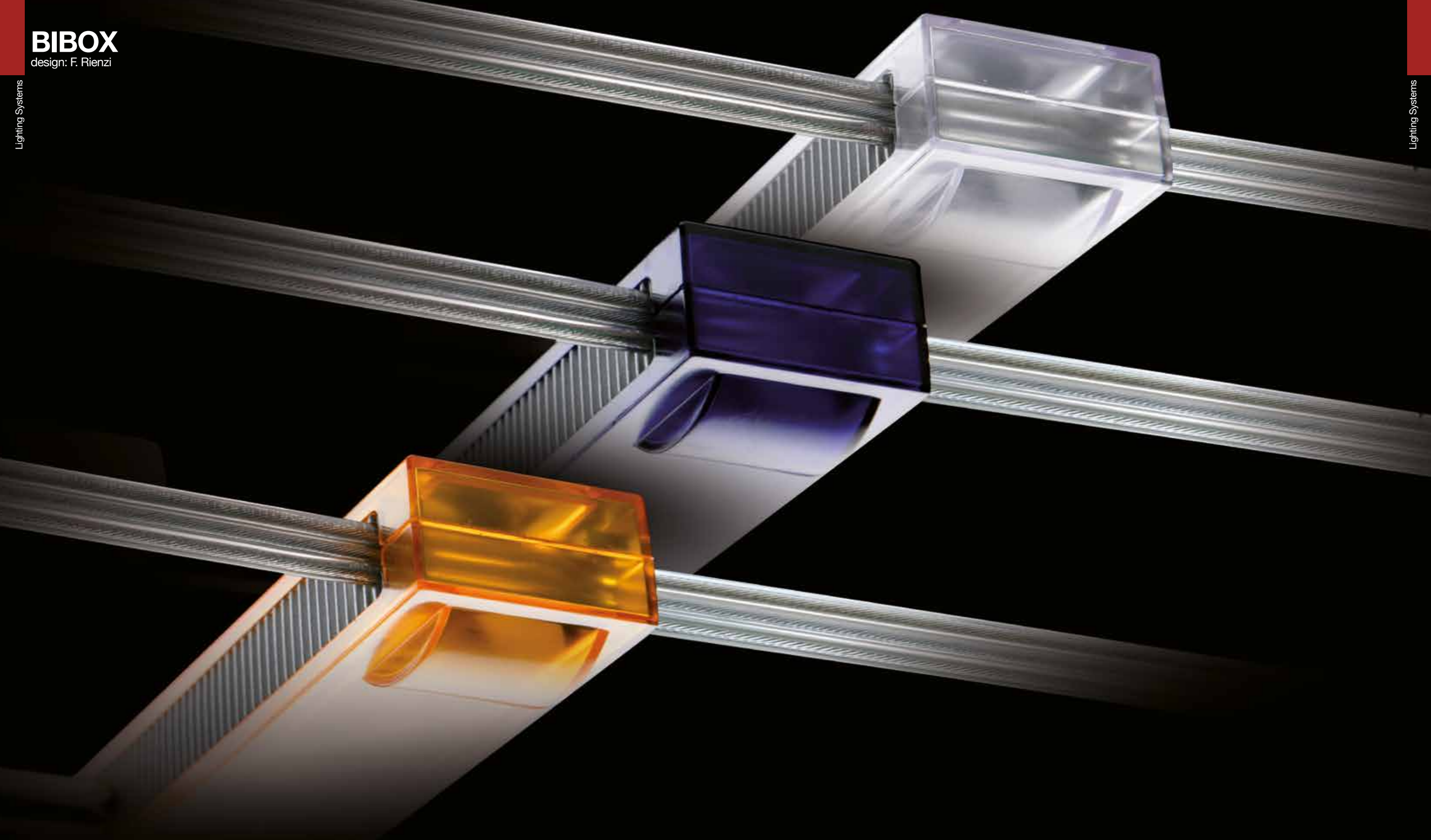

Sistema di illuminazione su cavi portanti e conduttori 230V per varie sorgenti luminose. Corpi in policarbonato trasparente o colorato con struttura e particolari in metallo cromato.

Technical Lighting Systems on carrying cable and conductor 230V for different kind of lighting sources. Body in transparent or coloured polycarbonate, with fittings and details in chromed metal.

Structure à câble porteur et de tension 230V pour être employée avec plusieurs sources lumineuses. Corps en polycarbonate transparent ou coloré avec structures et détails en laiton chromé

Tragseil-Leuchtsystem mit 230V Zuleitungen für verschiedene Leuchtmittel. Leuchtenkörper aus transparentem oder farbigem Polycarbonat und Struktur sowie Einzelteilen aus verchromtem Metall.

Sistema de iluminación sobre cable conductor para varias fuentes luminosas. Cuerpos en policarbonato transparente o colorado, con detalles en latón cromado.

Техническая осветительная система на несущем тросе с кабелем под 230В для разных видов источников света. Корпус в прозрачном или цветном поликарбонате с деталями в хромированном металле.

BIBOX HALO

design: F. Rienzi

Lighting Systems

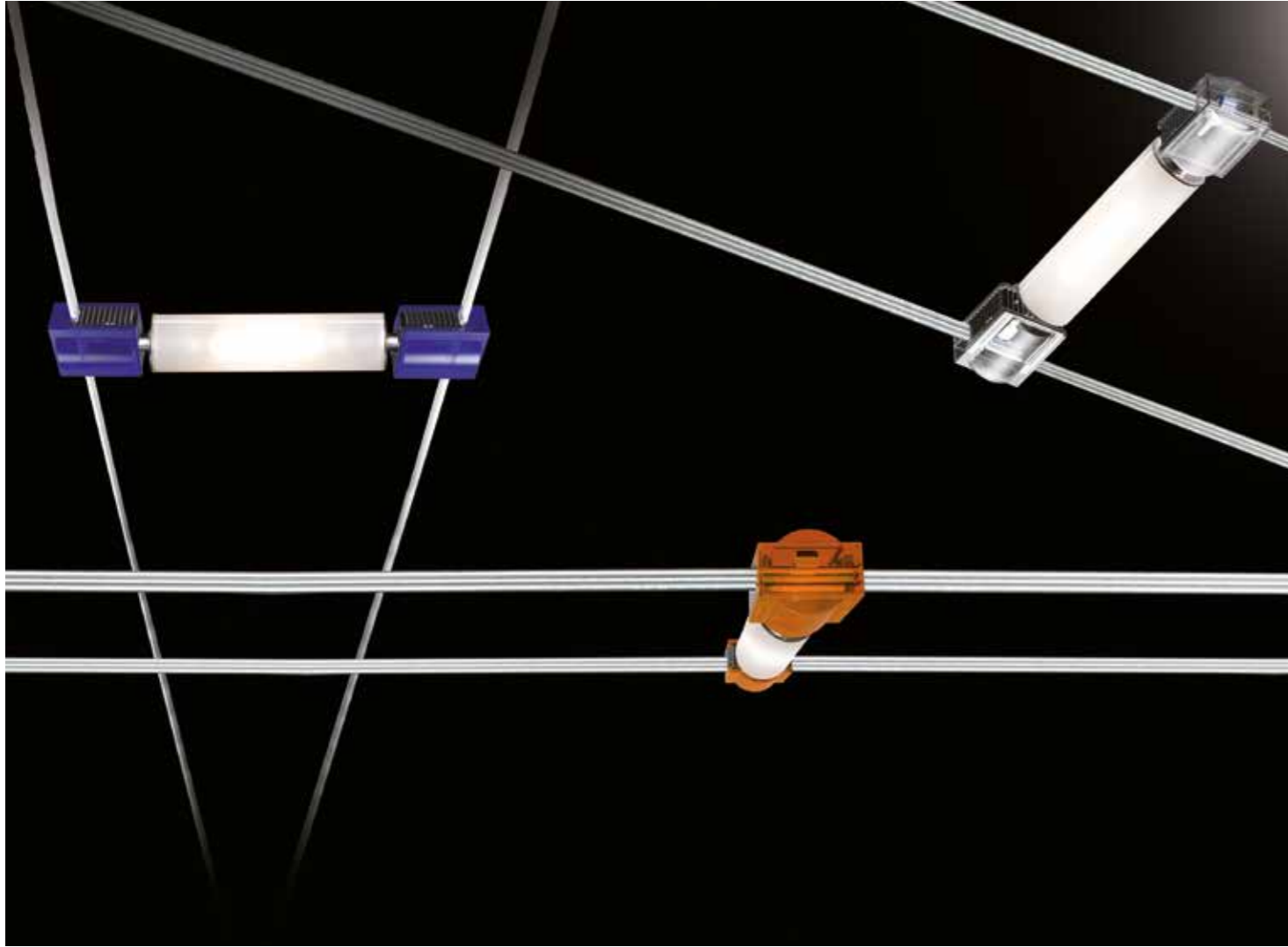

9000 0,5 kg
120W R7s (78 mm.) ECO

--	--	--

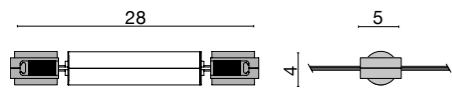

.00 .07 .09

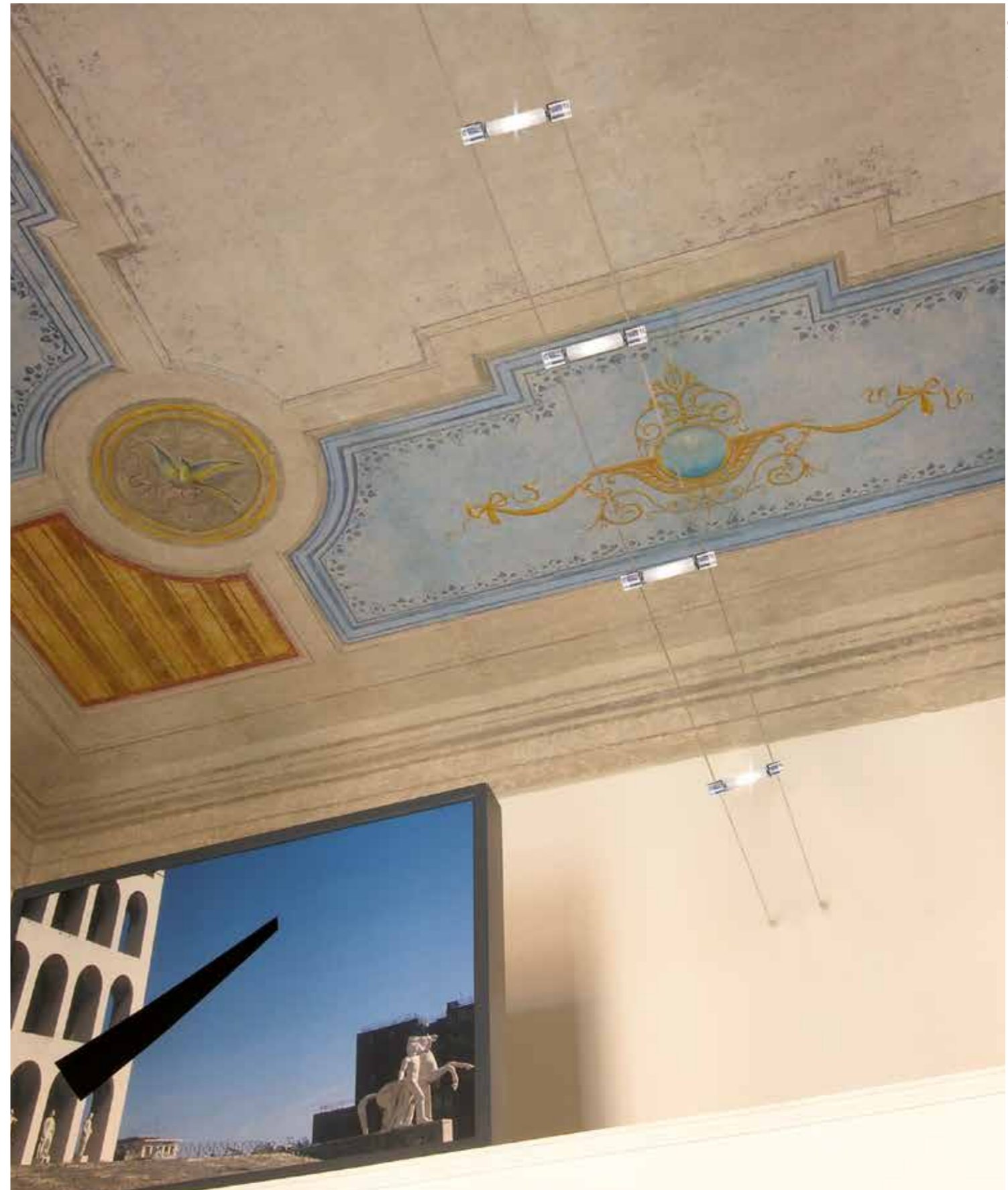

Lighting Systems

BIBOX SPOT

design: F. Rienzi

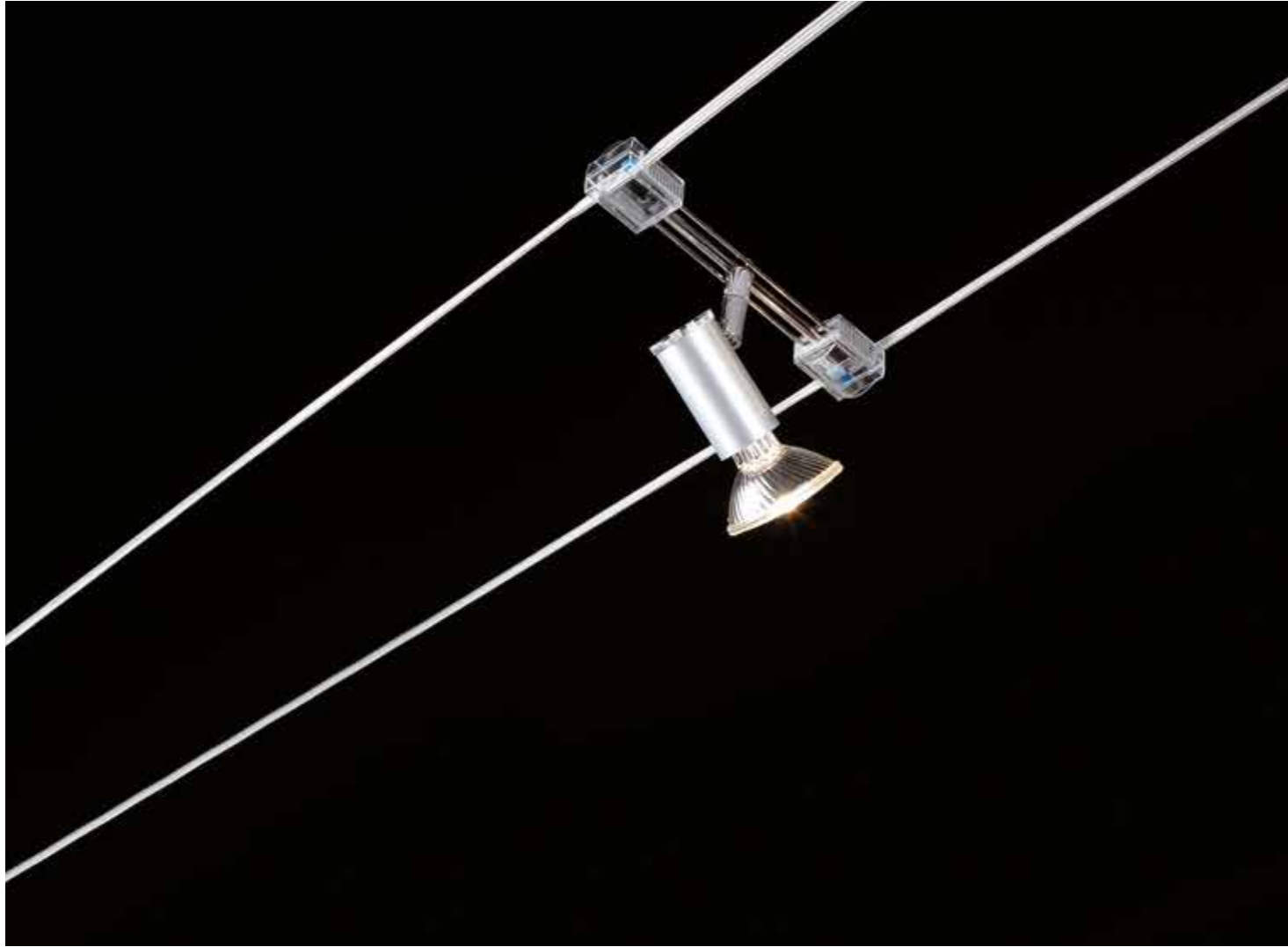

9002 0,5 kg

75W E27 PAR30 

16W E27 PAR30 LED 

F 

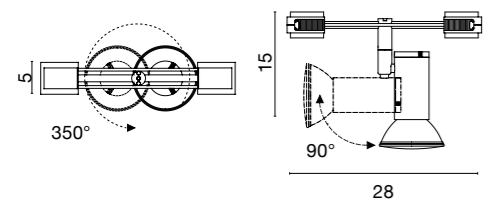

15

350°

90°

28

.00 .07 .09

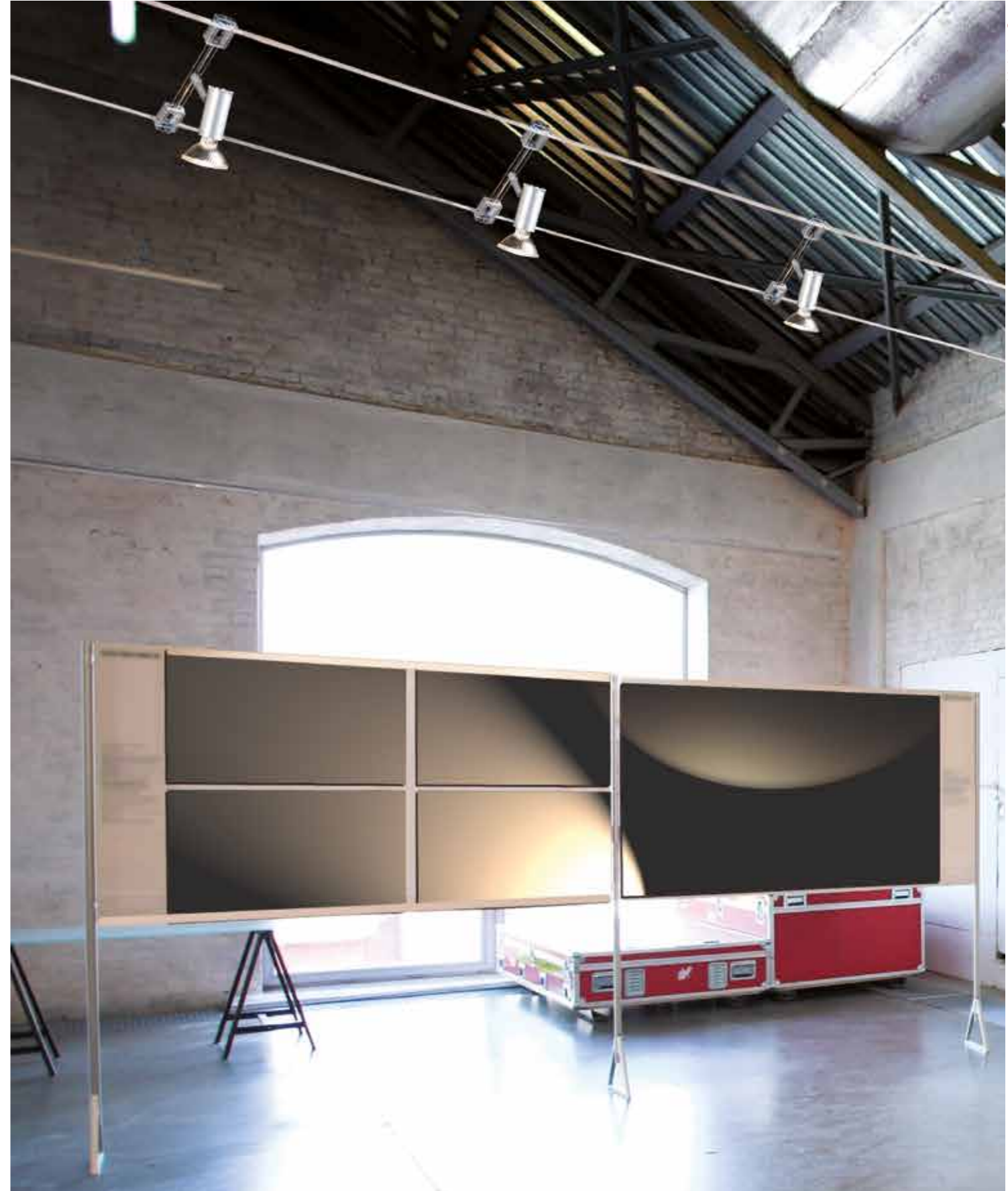

BIBOX FLUO

design: F. Rienzi

Lighting Systems



Lighting Systems

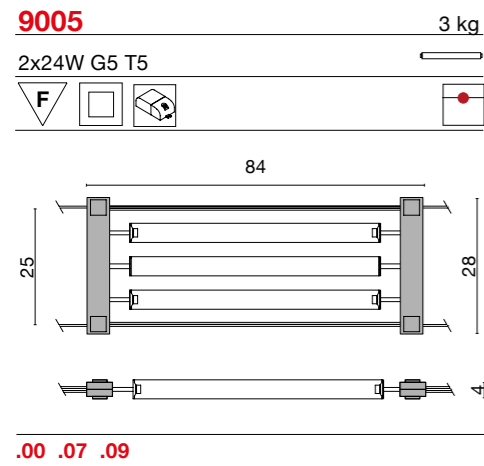

.00 .07 .09

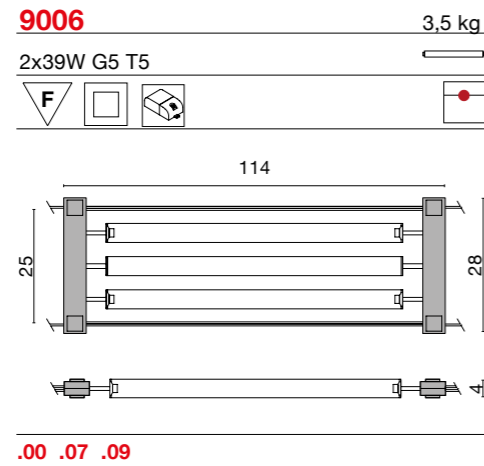

.00 .07 .09



ACCESSORI

- 9100 15 mt.
- 9101 30 mt.
- 9102 50 mt.
- 9103 100 mt.

Cavo

Cavo a 2 conduttori in rame per alimentazione e 1 centrale in acciaio per il sostegno. Consente 2 accensioni separate.

Cable with 2 copper wires for dual on/off function and 1 central steel wire to tighten the cable.



9108

Interruzioni

Raddoppiano accensioni e potenza installabile quando i cavi sono alimentati da entrambi i lati

Double the switching and installable power when cables are powered by both sides

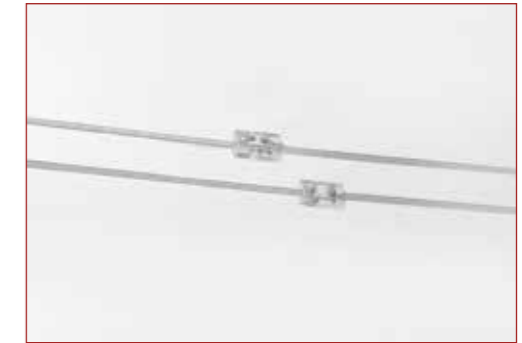

9105

Tenditori e alimentazione

Kit d'installazione:

1 base d'alimentazione (28x4,5 cm.) trasparente o colorata
4 tenditori in ottone cromato (max 26cm.)

Installation kit:

1 centralized power supply (28x4,5 cm.) transparent or coloured
4 chromed brass (max 26cm.) tensors



.00



.07



.09



9109

Sostegni

Riducono la freccia dei cavi.

Reduce the cables's strain.

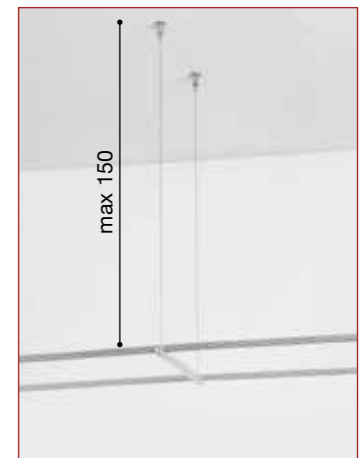

9106

Alimentatori separati

Base di alimentazione trasparente o colorata per alimentare il sistema in assenza di punti luce in prossimità dei tenditori.

Centralized power supply connection coloured or transparent.



.00



.07



.09

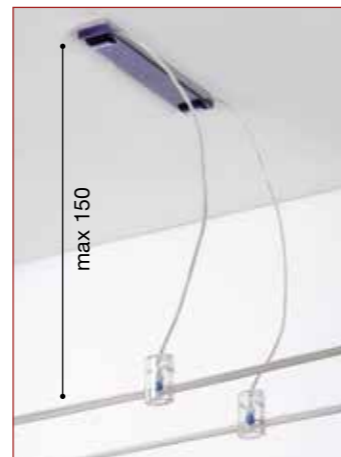

9110

Distanziatori

Per installazioni in assenza di una o entrambe le pareti.

For installing cables where one or both walls are not available.



9107

Connettori incrociati

Connettono più coppie di cavi per alimentarle da un solo punto luce.

Connects pair of cables so they can be powered by one power point.



9113

Deviatori 90°

Deviano i cavi da soffitti, pareti o pavimenti.

Wall deviation twin-set.



LUCCIOLA	p. 282
LUCCIOLA RGB	p. 283
DOT	p. 284
DOT PLUS	p. 286
SIRIO	p. 288
ALCOR	p. 290
ALCOR MAXI RGB	p. 292
VEGA	p. 294
VEGA MAXI RGB	p. 296
FIRE	p. 298
FIRE RGB	p. 300
ICE	p. 302
ICE RGB	p. 304

TOP	p. 306
TOP MINI	p. 308
BYTE	p. 310
PIX	p. 312
PIX RGB	p. 314
SNORKY	p. 316
SNORKY MAXI	p. 318
CERCHIETTO	p. 320
CRUISE	p. 322
TRIM	p. 324
SPOON	p. 328
SLOT	p. 332

DECORATIVE LIGHTS

LUCCIOLA

design: U.T. EGOLUCE

LUCCIOLA RGB

design: U.T. EGOLUCE



Faretto da incasso in alluminio verniciato bianco. Ideale per effetto cielo stellato. Possibilità di montaggio su pareti o soffitti in cartongesso e pannelli.
DISPONIBILE ANCHE A 2700/4000K

Spot encastré en aluminium verni blanc. Idéal pour plafonds étoilé. Montage sur faux plafonds ou cloisons en plaque plâtre ou bois.
DISPONIBLE AUSSI 2700/4000K

Foco para empotrar, en aluminio pintado blanco. Ideal para cielo estrellado. Posibilidad de instalación en pared o techo de placas de yeso y paneles.
TAMBIÉN DISPONIBLE 2700/4000K

Faretto RGB da incasso in alluminio verniciato bianco. Ideale per effetto cielo stellato. Possibilità di montaggio su pareti o soffitti in cartongesso e pannelli.
Sistema di controllo solo con telecomando.

Spot RGB encastré en aluminium verni blanc. Idéal pour plafonds étoilé. Montage sur faux plafonds ou cloisons en plaque plâtre ou bois.
Control seulement avec télécommande.

Foco RGB para empotrar, en aluminio pintado blanco. Ideal para cielo estrellado. Posibilidad de instalación en pared o techo de placas de yeso y paneles.
Sistema de control sólo con control a distancia.

Recessed spotlight in white lacquered aluminium. Ideal for starred sky effect. False ceiling or wall mounting into plasterboard or panels.
AVAILABLE ALSO 2700/4000K

Einbaustrahler aus weiß lackierten Aluminiumguss. Optimal für Sternenhimmel-Effekt. Montage auf Decken oder Wände aus Gipskarton oder Paneelen.
LIEFERBAR AUCH 2700/4000K

Встроенный светильник из окрашенного в белый цвет алюминия. Идеально подходит для создания эффекта звездного неба. Монтируется на потолок или на стену в гипсокартон или в деревянные панели.
ТАКЖЕ ДОСТУПНЫ 2700/4000K

Recessed RGB spotlight in white lacquered aluminium. Ideal for starred sky effect. False ceiling or wall mounting into plasterboard or panels.
Available with remote controller system only.

Einbaustrahler RGB aus weiß lackierten Aluminiumguss. Optimal für Sternenhimmel-Effekt. Montage auf Decken oder Wände aus Gipskarton oder Paneelen.
Funk-Controller nur mit Funkfernbedienung.

Встроенный светильник из окрашенного в белый цвет алюминия. Идеально подходит для создания эффекта звездного неба. Монтируется на потолок или на стену в гипсокартон или в деревянные панели.
Система управления только с пультом дистанционного управления.



6372 0,01 kg

0,16W 8V 20 mA DC

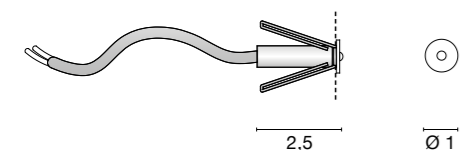

.01/B .01/CW .01/WW 0,8 cm.

Drivers



0130
(1-40 Lucciola)

.01/B



.01/CW

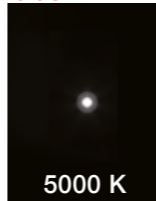

5000 K

.01/WW



3000 K

6353 0,01 kg

0,7W 12V DC

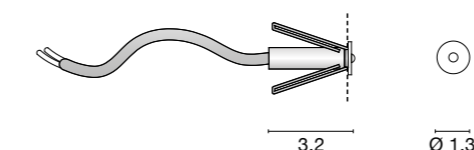

.01 0,8 cm.

Drivers



0152 + 0159 12V 25W
(1-26 Lucciola RGB)



0152 + 0173 12V 50W
(1-52 Lucciola RGB)

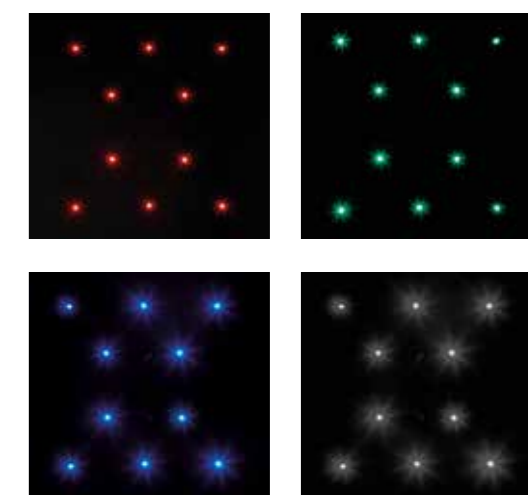

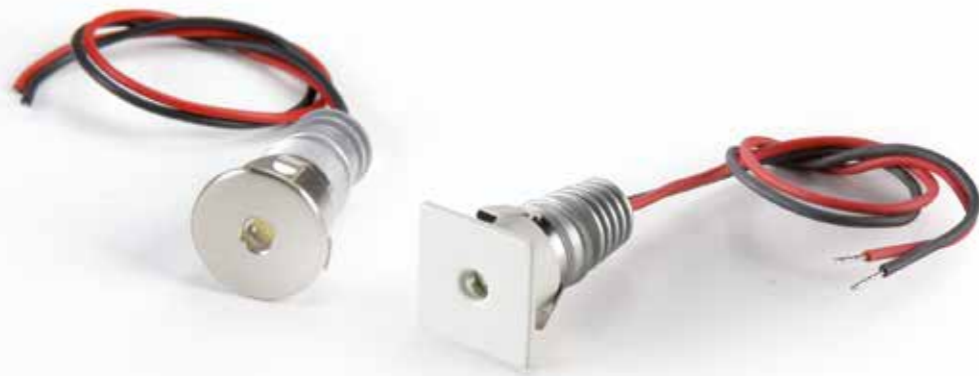

Faretto da incasso nichel satinato o bianco completo di dissipatore. Disponibile in versione tonda o quadrata. Possibilità di montaggio con o senza cassaforma e su doghe in metallo con adattatore (art. 0208).

Versione ETL disponibile a richiesta

Recessed spotlight in white or nickel matt finish, heat sink included. Available in round or square version. Mounting with or without junction box or on metal false ceiling with adapter (art. 0208). **ETL version available upon request**

Spot encastré en blanc ou nickel satiné. Disponible en version ronde ou carre. Montage avec ou sans boîte d'encastrement, ou sur faux plafond métallique avec anneau adaptateur (art. 0208).

Version ETL disponible sur demande

Einbaustrahler Ausfertigung Nickel matt oder weiss. Verfügbar in rund oder quadratisch. Montage mit oder ohne Einbaugehäuse. Montagering für Metalldecken (art. 0208).

Foco para empotrar, en níquel satinado o blanco. Disponible en versión redonda y cuadrada. Posibilidad de montar con o sin cajetín y en perfiles metálicos con adaptador (art. 0208).

Встроенный светильник с радиатором для отвода тепла. Матированный никель или окрашены в белый цвет. Круглый или квадратный варианты. Монтируется с монтажной коробкой или без нее или с фланцем для стального профиля (art. 0208).

6320 tondo 0,01 kg

/ww Led 1W 350 mA 81lm 3000K

/w Led 1W 350 mA 85lm 4000K

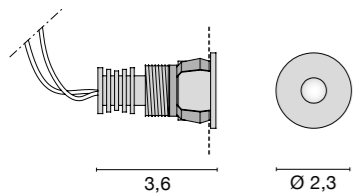

.01/W .32/W .01/WW .32/WW 2 cm.

6321 quadro 0,01 kg

/ww Led 1W 350 mA 81lm 3000K

/w Led 1W 350 mA 85lm 4000K

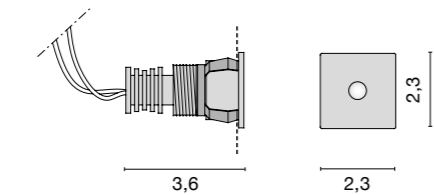

.01/W .32/W .01/WW .32/WW 2 cm.

Accessories



Drivers



DOT PLUS

design: U.T. EGOLUCE



Faretto da incasso bianco o nichel satinato completo di dissipatore. Possibilità di montaggio con o senza cassaforma. (IP 44)

Spot encastré en blanc ou nickel satiné. Montage avec ou sans boîte d'encastrement. (IP 44)

Foco para empotrar, en blanco o níquel satinado. Posibilidad de montar con o sin cajetín. (IP 44)

Recessed spotlight in white or nickel matt finish, heat sink included. Mounting with or without junction box. (IP 44)

Einbaustrahler Ausfertigung Weiss oder Nickel matt. Montage mit oder ohne Einbauehäuse. (IP 44)

Встроенный светильник с радиатором для отвода тепла. Матированный никель. Круглый или квадратный варианты. Монтируется с монтажной коробкой или без нее (IP 44)

6316 0,01 kg

.WW Led 1W 350 mA 143lm 3000K

.W Led 1W 350 mA 151lm 4000K

IP44

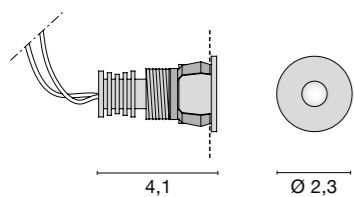

.01/W .32/W .01/WW .32/WW 2 cm.

Accessories



0212
Box + Plaster



0215
Plastic Box

Drivers



0125 350 mA
(1-6 Dot)



0128 350 mA
(1-10 Dot)



0129 Dimmer
0129/DALI Dimmer



0145 Dimmer Maxi
0145/DALI Dimmer M.



SIRIO

design: U.T. EGOLUCE

Decorative Lights



Faretto da incasso (IP 44) con diffusore in cristallo trasparente, flangia in alluminio cromato completo di dissipatore. Possibilità di montaggio con o senza cassaforma.

Versione ETL disponibile a richiesta

Recessed spotlight (IP 44) with clear crystal diffuser, frame in chromed aluminium. Heat sink included. Mounting with or without junction box.
ETL version available upon request

Spot encastré (IP44) avec diffuseur en cristal transparent, structure en métal chromé. Dissipateur de chaleur inclus. Montage avec ou sans boîte d'encastrement.

Version ETL disponible sur demande

Einbaustrahler (IP44) mit Diffusor aus klarem Kristall, Gestell aus verchromtem Aluminium. Inklusiv Kühlkörper. Montage mit oder ohne Einbaugehäuse.

Foco para empotrar (IP44) con pantalla de cristal transparente. Brida en aluminio cromado. Disipador de calor incluido. Posibilidad de instalación con o sin cajetín.

Встроенный спот из хромированного алюминия. Степень защиты (IP44) Прозрачный хрустальный диффузор. С радиатором для отвода тепла. Монтируется с монтажной коробкой или без нее.

6359 0,03 kg

WW Led 1W 350 mA 143lm 3000K

W Led 1W 350 mA 151lm 4000K

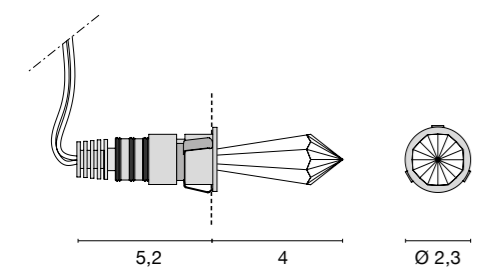

.50/W .50/WW 2 cm.

Accessories



Drivers

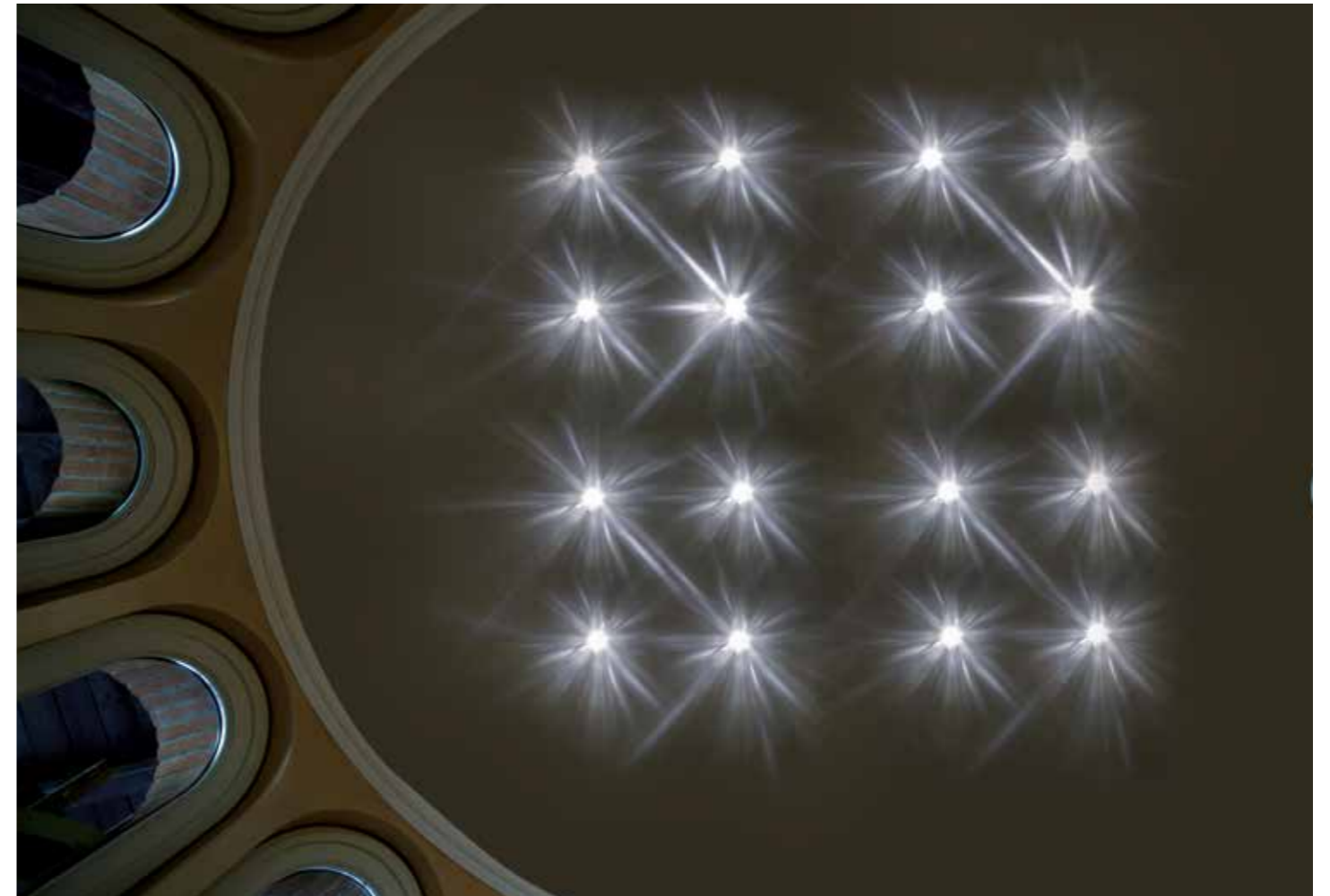

Decorative Lights

ALCOR

design: U.T. EGOLUCE



Faretto da incasso (IP 44) con diffusore in cristallo trasparente, flangia in alluminio cromato completo di dissipatore. Possibilità di montaggio con o senza cassaforma.

Versione ETL disponibile a richiesta

Recessed spotlight (IP 44) with clear crystal diffuser, frame in chromed aluminium. Heat sink included. Mounting with or without junction box.

ETL version available upon request

Spot encastré (IP44) avec diffuseur en cristal transparent, structure en métal chromé. Dissipateur de chaleur inclus. Montage avec ou sans boîte d'encastrement.

Version ETL disponible sur demande

Einbaustrahler (IP44) mit Diffusor aus klarem Kristall, Gestell aus verchromtem Aluminium. Inklusiv Kühlkörper. Montage mit oder ohne Einbaugeschäule.

Foco para empotrar (IP44) con pantalla de cristal transparente. Brida en aluminio cromado. Disipador de calor incluido. Posibilidad de instalación con o sin cajetín.

Встроенный спот из хромированного алюминия. Степень защиты IP44. Прозрачный хрустальный диффузор. С радиатором для отвода тепла. Монтируется с монтажной коробкой или без нее.

6360 0,03 kg

/WW Led 1W 350 mA 143lm 3000K

/W Led 1W 350 mA 151lm 4000K

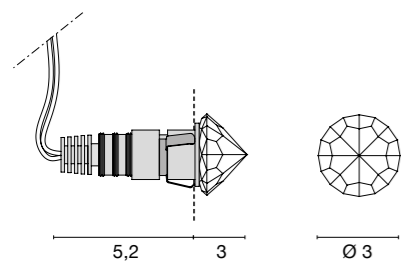

.50/W .50/WW 2 cm.

Accessories



0212
Box + Plaster

0215
Plastic Box

Drivers



0125 350 mA
(1-6 Alcor)

0128 350 mA
(1-10 Alcor)

0129 Dimmer
0129/DALI Dimmer

0145 Dimmer Maxi
0145/DALI Dimmer M.



ALCOR MAXI RGB

design: U.T. EGOLUCE

Decorative Lights



Faretto da incasso (IP 44) con diffusore in cristallo trasparente, flangia in alluminio cromato completo di dissipatore. Possibilità di montaggio con o senza cassaforma.

Versione ETL disponibile a richiesta

Recessed spotlight (IP 44) with clear crystal diffuser, frame in chromed aluminium. Heat sink included. Mounting with or without junction box.

ETL version available upon request

Spot encastré (IP44) avec diffuseur en cristal transparent, structure en métal chromé. Dissipateur de chaleur inclus. Montage avec ou sans boîte d'encastrement.

Version ETL disponible sur demande

Einbaustrahler (IP44) mit Diffusor aus klarem Kristall, Gestell aus verchromtem Aluminium. Inklusiv Kühlkörper. Montage mit oder ohne Einbaugehäuse.

Foco para empotrar (IP44) con pantalla de cristal transparente. Brida en aluminio cromado. Disipador de calor incluido. Posibilidad de instalación con o sin cajetín.

Встроенный спот из хромированного алюминия. Степень защиты IP44. Прозрачный хрустальный диффузор. С радиатором для отвода тепла. Монтируется с монтажной коробкой или без нее.

6379 0,1 kg

3 x 250 mA

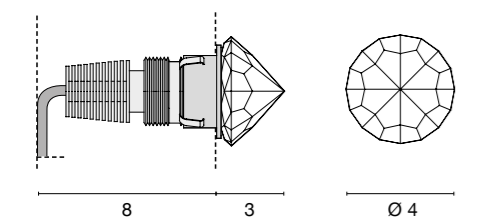

.50 3 cm.

Accessories



Drivers



Decorative Lights

VEGA

design: U.T. EGOLUCE



Faretto da incasso (IP 44) con diffusore in cristallo trasparente, flangia in alluminio cromato completo di dissipatore. Possibilità di montaggio con o senza cassaforma.

Versione ETL disponibile a richiesta

Recessed spotlight (IP 44) with clear crystal diffuser, frame in chromed aluminium. Heat sink included. Mounting with or without junction box. **ETL version available upon request**

Spot encastré (IP44) avec diffuseur en cristal transparent, structure en métal chromé. Dissipateur de chaleur inclus. Montage avec ou sans boîte d'encastrement.

Version ETL disponible sur demande

Einbaustrahler (IP44) mit Diffusor aus klarem Kristall, Gestell aus verchromtem Aluminium. Inklusiv Kühlkörper. Montage mit oder ohne Einbaugehäuse.

Foco para empotrar (IP44) con pantalla de cristal transparente. Brida en aluminio cromado. Disipador de calor incluido. Posibilidad de instalación con o sin cajetín.

Встроенный спот из хромированного алюминия. Степень защиты IP44. Прозрачный хрустальный диффузор. С радиатором для отвода тепла. Монтируется с монтажной коробкой или без нее.

6358 0,03 kg

/ww Led 1W 350 mA 143lm 3000K

/w Led 1W 350 mA 151lm 4000K

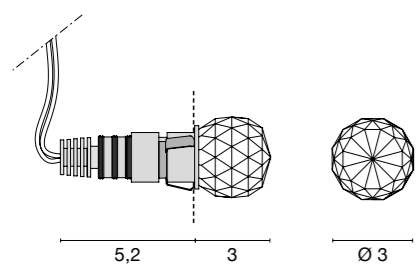

.50/W .50/WW 2 cm.

Accessories



0212
Box + Plaster



0215
Plastic Box

Drivers



0125 350 mA
(1-6 Vega)



0128 350 mA
(1-10 Vega)



0129 Dimmer
0129/DALI Dimmer



0145 Dimmer Maxi
0145/DALI Dimmer M.



VEGA MAXI RGB

design: U.T. EGOLUCE

Decorative Lights



Faretto da incasso (IP 44) con diffusore in cristallo trasparente, flangia in alluminio cromato completo di dissipatore. Possibilità di montaggio con o senza cassaforma.

Versione ETL disponibile a richiesta

Recessed spotlight (IP 44) with clear crystal diffuser, frame in chromed aluminium. Heat sink included. Mounting with or without junction box. **ETL version available upon request**

Spot encastré (IP44) avec diffuseur en cristal transparent, structure en métal chromé. Dissipateur de chaleur inclus. Montage avec ou sans boîte d'encastrement.

Version ETL disponible sur demande

Einbaustrahler (IP44) mit Diffusor aus klarem Kristall, Gestell aus verchromtem Aluminium. Inklusiv Kühlkörper. Montage mit oder ohne Einbaugehäuse.

Foco para empotrar (IP44) con pantalla de cristal transparente. Brida en aluminio cromado. Disipador de calor incluido. Posibilidad de instalación con o sin cajetín.

Встроенный спот из хромированного алюминия. Степень защиты IP44. Прозрачный хрустальный диффузор. С радиатором для отвода тепла. Монтируется с монтажной коробкой или без нее.

6378 0,1 kg

3 x 250 mA

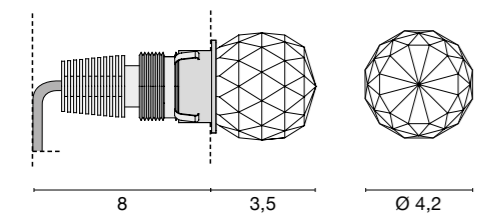

.50 3 cm.

Accessories



Drivers



Decorative Lights

FIRE

design: P. Pepere



Faretto da incasso (IP 44) in metacrilato trasparente con inclusione di bolle. Completo di dissipatore. Possibilità di montaggio con o senza cassaforma.

Versione ETL disponibile a richiesta

Recessed spotlight (IP 44). Transparent methacrylate diffuser with bubbles enclosure. Heat sink included.

Mounting with or without junction box.

ETL version available upon request

Spot encastré (IP 44). Diffuseur en méthacrylate transparent avec inclusion de boules. Dissipateur de chaleur inclus. Montage avec ou sans boîte d'encastrement.

Version ETL disponible sur demande

Einbaustrahler (IP 44). Diffusor aus transparentem Metakrylat mit Luftblasen. Inklusiv Kühlkörper. Montage mit oder ohne Einbaugehäuse.

Foco para empotrar (IP 44). Difusor en metacrilato transparente con inclusión de bolas. Dissipador de calor incluido. Posibilidad de montaje en pared o techo, con o sin cajetín.

Встроенный светильник (IP 44) с диффузором из прозрачного метакрилата с пузырьками воздуха внутри. С радиатором для отвода тепла. Монтируется с монтажным корпусом или без него.

6340 0,01 kg

/ww Led 1W 350 mA 143lm 3000K

/w Led 1W 350 mA 151lm 4000K

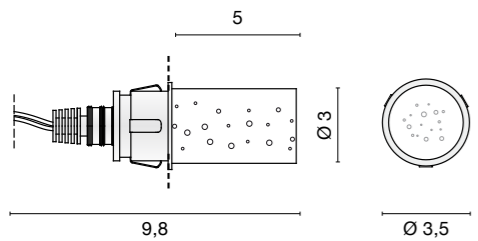

.00/W .00/WW 3 cm.

Accessories



0213
Box + Plaster



0216
Plastic Box

Drivers



0125 350 mA
(1-6 Fire)



0128 350 mA
(1-10 Fire)



0129 Dimmer
0129/DALI Dimmer



0145 Dimmer Maxi
0145/DALI Dimmer M.

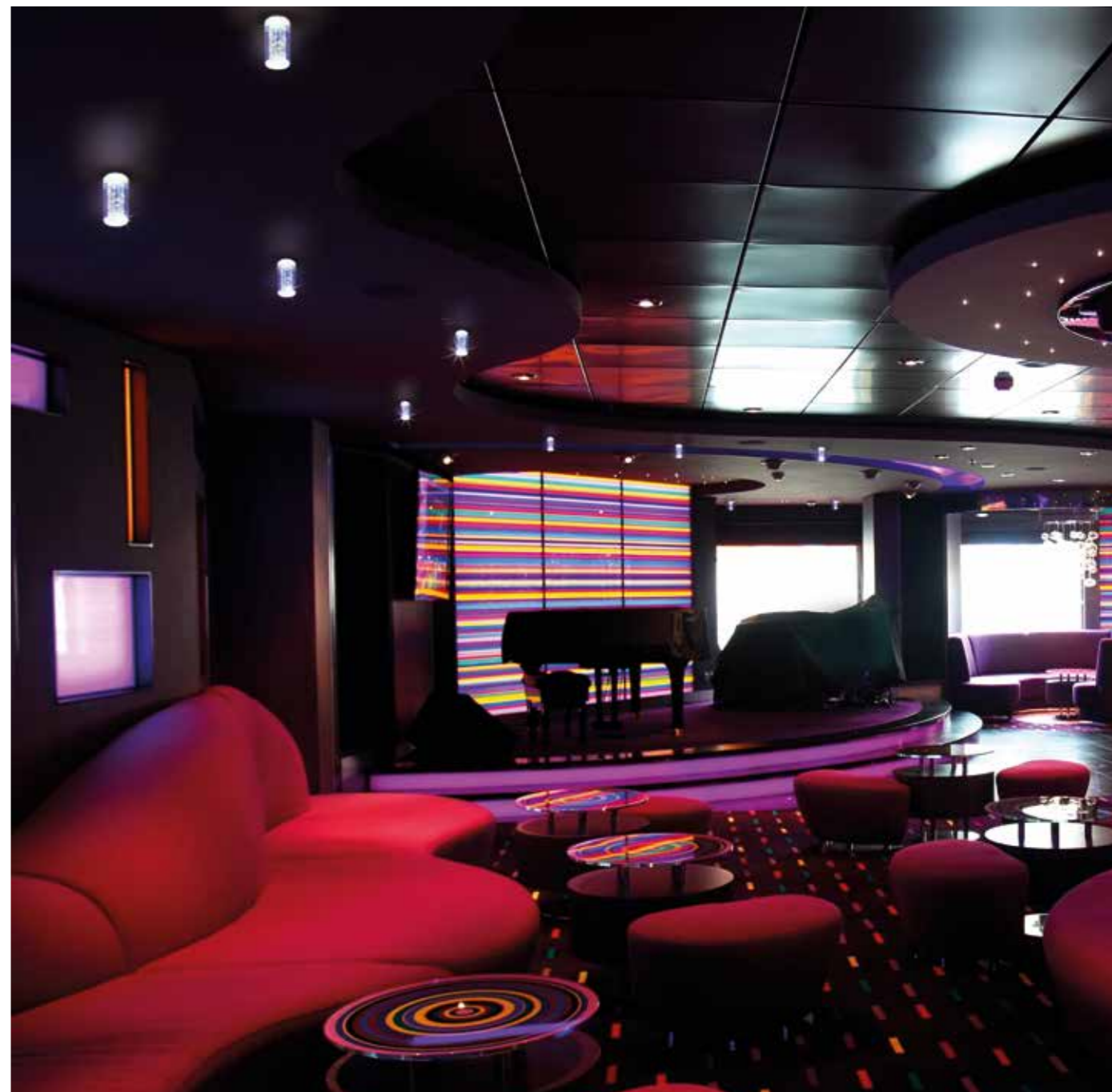

FIRE RGB

design: P. Pepere

Decorative Lights



Faretto da incasso (IP 44) in metacrilato trasparente con inclusione di bolle. Completo di dissipatore. Possibilità di montaggio con o senza cassaforma.

Versione ETL disponibile a richiesta

Recessed spotlight (IP 44). Transparent methacrylate diffuser with bubbles enclosure. Heat sink included. Mounting with or without junction box.

ETL version available upon request

Spot encastré (IP44). Diffuseur en méthacrylate transparent avec inclusion de boules. Dissipateur de chaleur inclus. Montage avec ou sans boîte d'encastrement.

Version ETL disponible sur demande

Einbaustrahler (IP44). Diffusor aus transparentem Metakrylat mit Luftblasen. Inklusiv Kühlkörper. Montage mit oder ohne Einbaugehäuse.

Foco para empotrar (IP44). Difusor en metacrilato transparente con inclusión de bolas. Dissipador de calor incluido. Posibilidad de montaje en pared o techo, con o sin cajetín.

Встроенный светильник (IP44) с диффузором из прозрачного метакрилата с пузырьками воздуха внутри. С радиатором для отвода тепла. Монтируется с монтажным корпусом или без него.

6341 0,1 kg

3 x 250 mA

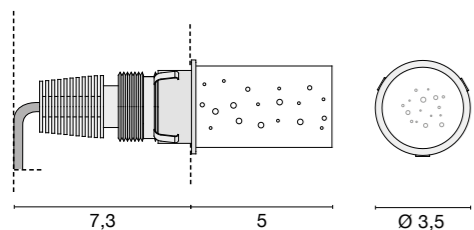

.00 3,2 cm.

Accessories



0234
Plastic Box



0163
IR Sensor



0165
IR Remote Controller



0166
Sync. Cable

Drivers



0164
Driver RGB 120W



0167
Driver RGB 22W



0168
Converter 1/5 RGB



Decorative Lights



Faretto da incasso (IP44) in metacrilato satinato. Disponibile con Led bianco o colorato (blu). Completo di dissipatore. Possibilità di montaggio con o senza cassaforma.

Versione ETL disponibile a richiesta

Recessed spotlight (IP44), frosted methacrylate diffuser. Available with white or coloured LED (blue). Heat sink included. Mounting with or without junction box.

ETL version available upon request

Spot encastré (IP44), avec diffuseur en méthacrylate satiné. Dissipateur de chaleur inclus. Disponible avec LED blanc ou coloré (bleu). Prévu pour installation avec ou sans boîte d'encastrement.

Version ETL disponible sur demande

Einbaustrahler (IP44), diffuser aus satiniertem Metakrylat. Inklusiv Kühlkörper. Verfügbar mit weißem oder farbigem LED (Blau). Montage mit oder ohne Einbaugehäuse.

Foco para empotrar (IP44), con pantalla en metacrilato satinado. Dissipador de calor incluido. Disponible con LED en blanco o coloreado (azul). Posibilidad de montaje con o sin cajetín.

Встроенный спот (IP44), из сатинированного метакрилата. С белым или цветным светодиодом (синим). С радиатором для отвода тепла. Монтируется с монтажной коробкой или без нее.

6354 Tondo 0,03 kg

/WW Led 1W 350 mA 143lm 3000K

/W Led 1W 350 mA 151lm 4000K

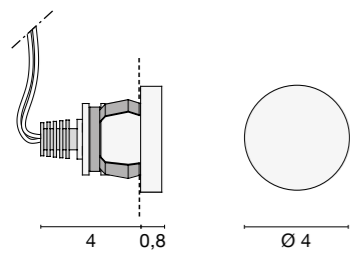

.01/W .01/WW .01/B 3 cm.

6355 Quadro 0,03 kg

/WW Led 1W 350 mA 143lm 3000K

/W Led 1W 350 mA 151lm 4000K

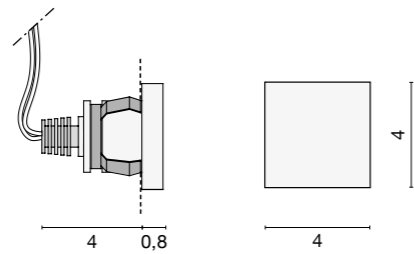

.01/W .01/WW .01/B 3 cm.



Accessories



Drivers



ICE RGB

design: U.T. EGOLUCE

Decorative Lights



Faretto da incasso (IP44) in metacrilato satinato. Completo di dissipatore. Possibilità di montaggio con o senza cassaforma.

Versione ETL disponibile a richiesta

Recessed spotlight (IP44), frosted methacrylate diffuser. Heat sink included. Mounting with or without junction box.

ETL version available upon request

Spot encastré (IP44), avec diffuseur en méthacrylate satiné. Dissipateur de chaleur inclus. Prévu pour installation avec ou sans boîte d'encastrement.

Version ETL disponible sur demande

Einbaustrahler (IP44), diffusor aus satiniertem Metakrylat. Inklusiv Kühlkörper. Montage mit oder ohne Einbauehäuse.

Foco para empotrar (IP44), con pantalla en metacrilato satinado. Disipador de calor incluido. Posibilidad de montaje con o sin cajetín.

Встроенный спот (IP44), из сатинированного метакрилата. Монтируется с монтажной коробкой или без нее.

6377 0,05 kg

3 x 250 mA

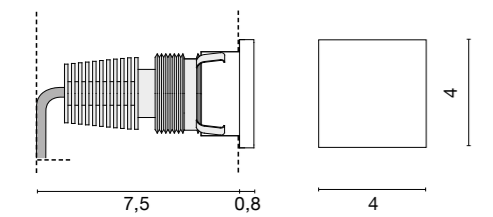

.01 3,2 cm.



Accessories



0234
Plastic Box



0163
IR Sensor



0165
IR Remote Controller



0166
Sinc. Cable

Drivers



0164
Driver RGB 120W



0167
Driver RGB 22W



0168
Converter 1/5 RGB



Decorative Lights

TOP

design: U.T. EGOLUCE

Decorative Lights



Faretto da incasso in alluminio verniciato bianco, completo di dissipatore. Ideale per piccole vetrine. Possibilità di montaggio con o senza cassaforma.

Versione ETL disponibile a richiesta

Recessed spotlight, white painted aluminium body, heat sink included. Ideal to light up small display cases. Mounting with or without junction box.

ETL version available upon request

6363 0,03 kg

/WW Led max 2W 500 mA 199lm 3000K 

/W Led max 2W 500 mA 209lm 4000K 

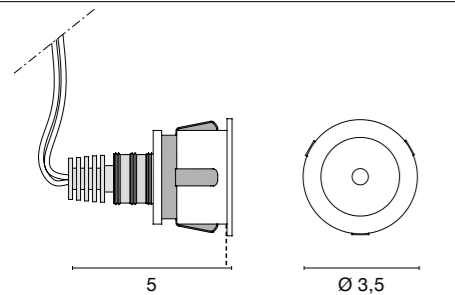

.01/WW .01/W  3 cm.

Accessories



0213
Box + Plaster

0216
Plastic Box

Drivers



0125 350 mA
(1-6 Top)

0127 500 mA
(1-6 Top)

0128 350 mA
(1-10 Top)

0129 Dimmer
0129/DALI Dimmer

0145 Dimmer Maxi
0145/DALI Dimmer M.



Decorative Lights

TOP MINI

design: U.T. EGOLUCE

Decorative Lights



Faretto da incasso in alluminio verniciato bianco, completo di dissipatore. Ideale per piccole vetrine. Possibilità di montaggio con o senza cassaforma.

Versione ETL disponibile a richiesta

Recessed spotlight, white painted aluminium body, heat sink included. Ideal to light up small display cases. Mounting with or without junction box.

ETL version available upon request

Spot encastré en aluminium verni blanc. Dissipateur de chaleur inclus. Idéale pour l'éclairage des petites vitrines. Prévu pour installation avec ou sans boîte d'encastrement.

Version ETL disponible sur demande

Einbaustrahler aus Aluminium, Ausführung weiß lackiert. Optimal für Vitrinen-Beleuchtung. Inklusiv Kühlkörper. Montage mit oder ohne Einbauehäuse.

Foco para empotrar en aluminio pintado blanco. Disipador de calor incluido. Ideal para pequeñas vitrinas. Posibilidad de montaje con o sin cajetín.

Встроенный спот из белого окрашенного алюминия. С радиатором для отвода тепла. Идеально подходит для небольших витрин. Монтируется с монтажной коробкой или без нее.

6364	0,03 kg
/WW Led 1W 350 mA 143lm 3000K	
/W Led 1W 350 mA 151lm 4000K	
IP40	

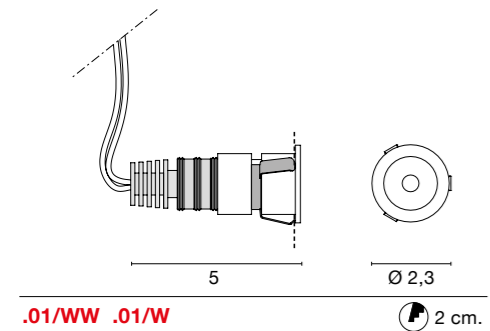

Accessories

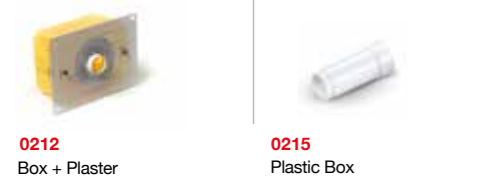

Drivers



Decorative Lights

BYTE

design: U.T. EGOLUCE



Faretto da incasso in alluminio anodizzato o verniciato bianco, completo di dissipatore. Ideale per piccole vetrine. Possibilità di montaggio con o senza cassaforma.

Versione ETL disponibile a richiesta

Recessed spotlight, white painted or anodized aluminium body, heat sink included. Ideal to light up small display cases. Mounting with or without junction box.

ETL version available upon request

Spot encastré en aluminium verni blanc ou anodisé. Dissipateur de chaleur inclus. Idéale pour l'éclairage des petites vitrines. Prévu pour installation avec ou sans boîte d'encastrement.

Version ETL disponible sur demande

Einbaustrahler aus Aluminium, Ausführung weiß lackiert oder eloxiert. Optimal für Vitrinen-Beleuchtung. Inklusiv Kühlkörper. Montage mit oder ohne Einbaueinheit.

Foco para empotrar en aluminio pintado blanco o anodizado. Disipador de calor incluido. Ideal para pequeñas vitrinas. Posibilidad de montaje con o sin cajetín.

Встроенный спот из белого окрашенного алюминия алюминия. С радиатором для отвода тепла. Идеально подходит для небольших витрин. Монтируется с монтажной коробкой или без нее.

6356 tondo	0,03 kg
/ww Led max 2W 500 mA 199lm 3000K	
/w Led max 2W 500 mA 209lm 4000K	

6357 quadro	0,03 kg
/ww Led max 2W 500 mA 199lm 3000K	
/w Led max 2W 500 mA 209lm 4000K	

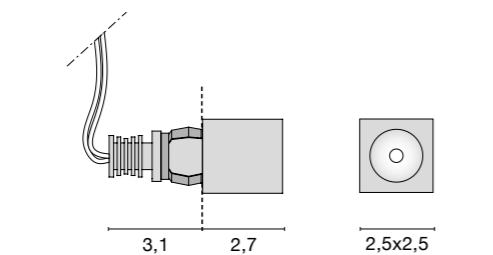
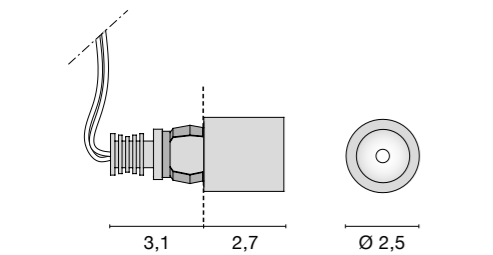

.01/WW .01/W .45/WW .45/W

.01/WW .01/W .45/WW .45/W

Accessories



Drivers





Faretto da incasso, nichel satinato o verniciato bianco, realizzato in versione tonda o quadrata. Completo di dissipatore. Possibilità di montaggio con o senza cassaforma o su doghe con adattatore (art.0209).

Versione ETL disponibile a richiesta

Recessed spotlight in nickel matt finish or white painted. Heatsink included. Available in round or square version. Installation with or without junction box and on metal false ceiling with adapter (art.0209).

ETL version available upon request

Spot encastré en finition nickel satiné ou verni blanc. Dissipateur de chaleur inclus. Disponible en version carré ou ronde. Idéal pour éclairage de vitrines. Montage, avec ou sans boîte d'encastrement, ou sur faux plafond métallique avec anneau adaptateur (art.0209).

Version ETL disponible sur demande

Einbaustrahler, Ausführung Nickel matt oder weiss lackiert. Inklusiv Kühlkörper. Verfügbar in rund oder quadratisch. Optimal für Vitrinen-Beleuchtung. Montage mit oder ohne Einbaugehäuse. Montagering für Metaldecken (art.0209).

Foco para empotrar, en níquel satinado o pintado blanco. Disipador de calor incluido. Disponible en version cuadrada y redonda. Ideal para iluminación de vitrinas. Posibilidad de montaje, con o sin cajetín en falsos techos. En perfiles metálicos se pone con adaptador (art.0209).

Встроенный спот из матированного никеля. С радиатором для отвода тепла. Круглый или квадратный варианты. Монтируется с монтажной коробкой или без нее или с фланцем для монтажа в стальной профиль (арт 0209).

6322 tondo 0,05 kg



.01 .32 3,2 cm.

Source LED cod.	OPTIC degree	LED color
/WW	/11 /25 /45	Led max 2W 500 mA 199lm 3000K
/W	/11 /25 /45	Led max 2W 500 mA 209lm 4000K

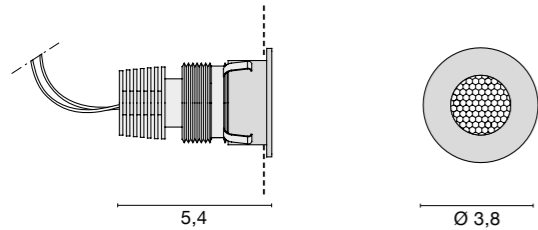

6323 quadro 0,05 kg



.01 .32 3,2 cm.

Source LED cod.	OPTIC degree	LED color
/WW	/11 /25 /45	Led max 2W 500 mA 199lm 3000K
/W	/11 /25 /45	Led max 2W 500 mA 209lm 4000K

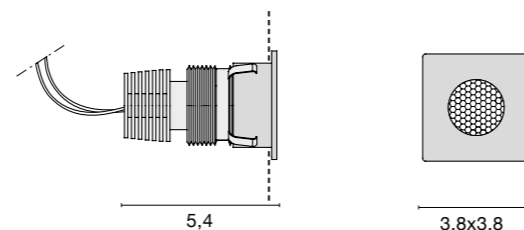

Accessories



Drivers



PIX RGB

design: U.T. EGOLUCE

Decorative Lights



Faretto da incasso, nichel satinato. Completo di dissipatore in alluminio e cavo in neoprene da 30 cm. Possibilità di montaggio con o senza cassa-forma o su doghe con adattatore (art.0209).

Versione ETL disponibile a richiesta

Recessed spotlight in nickel matt finish. Complete of aluminium heat sink and 30 cm. neoprene cable. Mounting with or without junction box and on metal false ceiling with adapter (art.0209).

ETL version available upon request

Spot encastré en finition nickel satiné. Dissipateur de chaleur en aluminium. Câble en néoprène 30 cm. Montage avec ou sans boîte d'encastrement, ou sur faux plafond métallique avec anneau adaptateur (art.0209).

Version ETL disponible sur demande

Einbaustrahler, Ausführung Nickel matt. Inklusiv Kühlkörper aus Aluminium und Neopren Stromkabel 30 cm. Montage mit oder ohne Einbaugehäuse. Montagering für Metaldecken verfügbar als Zubehör (Art. 0209).

Foco para empotrar, en níquel satinado. Disipador de calor y cable en neoprene de 30 cm. incluidos. Posibilidad de montaje, con o sin cajetín y en perfiles metálicos con accesorio adaptador. (art. 0209).

Встроенный спот. Матированный никель. С радиатором для отвода тепла и кабелем из неопрена 30 см. Монтируется на потолок или на стену с монтажной коробкой или без нее или с фланцем для монтажа в стальной профиль (арт 0209).

6375 0,1 kg

3 x 250 mA

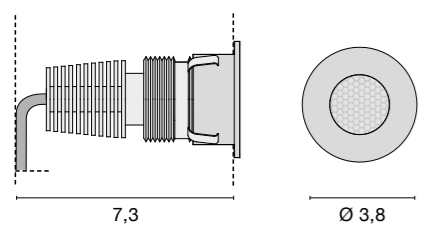
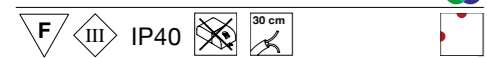

.32 3,2 cm.

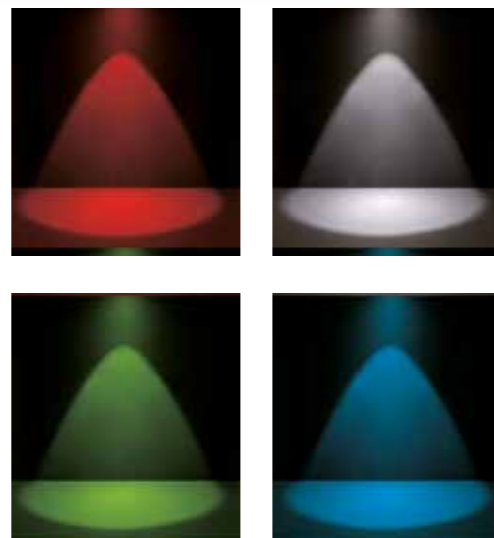

Accessories



Drivers



Decorative Lights

SNORKY

design: U.T. EGOLUCE



Faretto orientabile da incasso in alluminio cromato. Completo di dissipatore. L'utilizzo di un nuovo tipo di Led ha reso possibile la creazione di un piccolo oggetto con elevate prestazioni. Possibilità di montaggio con o senza cassaforma.

Versione ETL disponibile a richiesta

Adjustable recessed spotlight in chromed aluminium, heat sink included. The use of a latest generation Led enabled the creation of a small object with high performances.

Installation with or without junction box.

ETL version available upon request

Spot encastré orientable en finition aluminium chromé. Dissipateur de chaleur inclus. L'utilisation d'une source LED de dernière génération a permis la création d'un objet de dimensions réduites avec performances élevées. Montage avec ou sans boîte d'encastrement.

Version ETL disponible sur demande

Schwenkbarer Einbaustrahler aus verchromtem Aluminium. Inklusiv Kühlkörper. Dieses Gerät ist mit einem neuen kleine hochleistungs-LED Bestückt. Montage mit oder ohne Einbauegehäuse.

Foco orientable para empotrar de aluminio cromado. Disipador de calor incluido. La utilización de un nuevo tipo de LED ha hecho posible la creación de un objeto pequeño con elevadas prestaciones. Posibilidad de montaje con o sin cajetín.

Встроенный поворотный светильник. Хромированный алюминий. С радиатором для отвода тепла. Светодиод последнего поколения позволяет создать светильник еще меньшего размера, сохраняя отличные характеристики. Монтируется с монтажной коробкой или без нее.

6373	0,03 kg
/ww Led 1W 350 mA 143lm 3000K	
/w Led 1W 350 mA 151lm 4000K	
IP40	

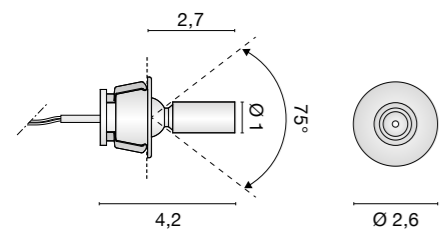

.31/WW .31/W 2 cm.

Accessories



Drivers



SNORKY MAXI

design: U.T. EGOLUCE

Decorative Lights



Faretto orientabile da incasso in alluminio cromato. Completo di dissipatore. Possibilità di montaggio con o senza cassaforma.

Adjustable recessed spotlight in chromed aluminium, heat sink included. Installation with or without junction box.

Spot encastré orientable en finition aluminium chromé. Dissipateur de chaleur inclus. Montage avec ou sans boîte d'encastrement.

Schwenkbarer Einbaustrahler aus verchromtem Aluminium. Inklusiv Kühlkörper. Dieses Gerät ist mit einem neuen hochleistungs-LED Bestückt. Montage mit oder ohne Einbaugehäuse.

Foco orientable para empotrar en aluminio cromado. Disipador de calor incluido. Posibilidad de montaje con o sin cajetín.

Встроенный поворотный светильник. Хромированный алюминий. С радиатором для отвода тепла. Монтируется с монтажной коробкой или без нее.

6313 snorky maxi 0,06 kg

/WW Led max 2W 500 mA 199lm 3000K 

/W Led max 2W 500 mA 209lm 4000K 

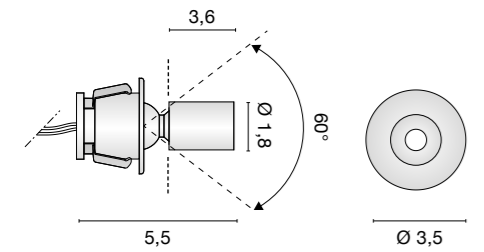

.31/WW .31/W 

Accessories



0213
Box + Plaster



0216
Plastic Box

Drivers



0125 350 mA
(1-6 Snorky maxi)



0127 500 mA
(1-6 Snorky maxi)



0128 350 mA
(1-10 Snorky maxi)



0129 Dimmer
0129/DALI Dimmer



0145 Dimmer Maxi
0145/DALI Dimmer M.



Decorative Lights

CERCHIETTO

design: U.T. EGOLUCE

Decorative Lights



Faretto da incasso (IP 44) in alluminio verniciato bianco. Disponibile con Led bianco o blu. Completo di dissipatore. Possibilità di montaggio con o senza cassaforma.

Versione ETL disponibile a richiesta

Recessed spotlight (IP44), white painted aluminium body. Available with white or blue Led. Heatsink included. Mounting with or without junction box.

ETL version available upon request

Spot encastré (IP44), corps en aluminium verni blanc. Disponible avec LED blanc ou bleu. Dissipateur de chaleur inclus. Montage avec ou sans boîte d'encastrement.

Version ETL disponible sur demande

Eibastrahler (IP44), Gestell aus Aluminium, Ausführung weiß lackiert. Verfügbar mit weißem oder blauem LED. Inklusiv Kühlkörper. Montage mit oder ohne Einbaugeschäuse.

Foco orientable para empotrar (IP44), de aluminio pintado blanco. Disponible con LED blanco o azul. Disipador de calor incluido. Posibilidad de montaje con o sin cajetín.

Встроенный светильник (IP44) из окрашенного алюминия. С белым или синим светодиодами. С радиатором для отвода тепла. Монтируется с монтажной коробкой или без нее.

6391 0,03 kg

/WW Led max 2W 500 mA 199lm 3000K

/W Led max 2W 500 mA 209lm 4000K

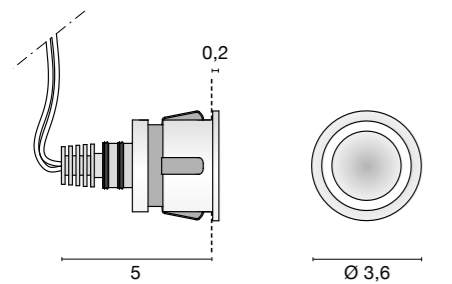

.01/WW .01/W .01/B 3 cm.

Accessories



Drivers

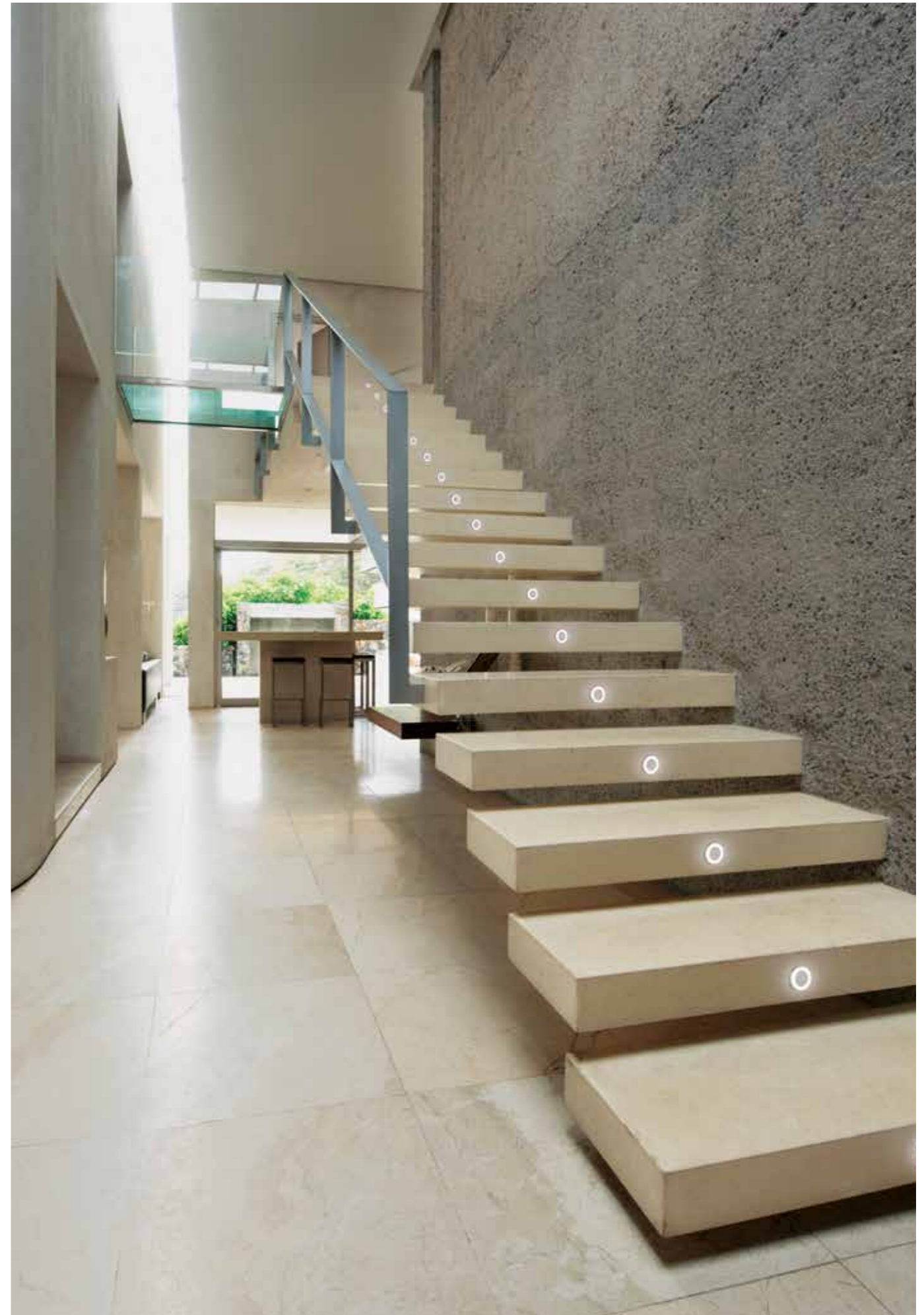

Decorative Lights



Faretto da incasso in alluminio verniciato bianco. Disponibile con Led bianco o blu. Completo di dissipatore. Possibilità di montaggio con o senza cassaforma.

Versione ETL disponibile a richiesta

Recessed spotlight, white painted aluminium body. Available with white or blue Led. Heatsink included. Mounting with or without junction box. **ETL version available upon request**

Spot encastré, corps en aluminium verni blanc. Disponible avec LED blanc ou bleu. Dissipateur de chaleur inclus. Montage avec ou sans boîte d'encastrement.

Version ETL disponible sur demande

Eibastrahler, Gestell aus Aluminium, Ausführung weiß lackiert. Verfügbar mit weißem oder blauem LED. Inklusiv Kühlkörper. Montage mit oder ohne Einbauehäuse.

Foco empotrable, de aluminio pintado blanco. Disponible con LED blanco o azul. Disipador de calor incluido. Posibilidad de montaje con o sin cajetín.

Встроенный светильник из окрашенного алюминия. С белым или синим светодиодом. С радиатором для отвода тепла. Монтируется с монтажной коробкой или без нее.

6382 0,02 kg

.01/WW Led 1W 350 mA 143lm 3000K

.01/W Led 1W 350 mA 151lm 4000K

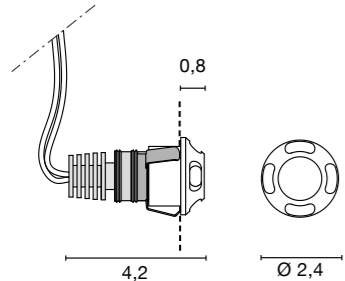

.01/WW .01/W .01/B 2 cm.

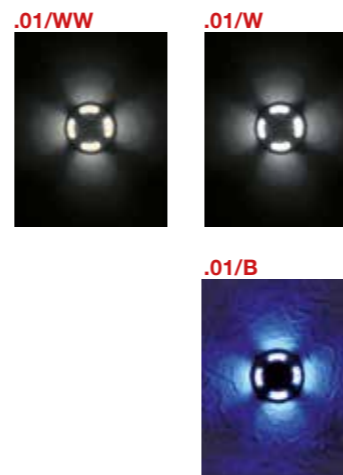

Accessories

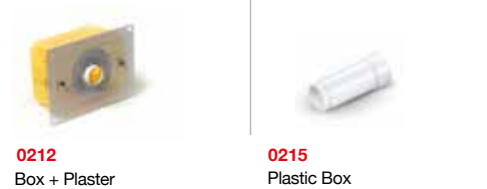

Drivers



TRIM

design: U.T. EGOLUCE



Faretto da incasso in alluminio anodizzato o verniciato bianco. Completo di dissipatore. Realizzato in versione tonda o quadrata con luce monodirezionale. Possibilità di montaggio con o senza cassaforma.

Recessed spotlight, white painted or anodized aluminium body. Heatsink included. Round or square version. Single side grazing light emission. Installation with or without junction box.

Spot encastré en aluminium, finition anodisé ou verni blanc. Dissipateur inclus. Disponible en Ronde ou carré. Emit un faisceau de lumière rasante unidirectionnel. Montage avec ou sans boîte d'encastrement.

Einbaustrahler aus Aluminium eloxiert oder weiß lackiert. Verfügbar in Rund oder quadratisch. Inklusiv Kühlkörper. Streifende Lichtstrahlung. Montage mit oder ohne Einbaugeschäuse.

Foco para empotrar en aluminio anodizado o pintado blanco. Disipador de calor incluido. Disponible en redondo y cuadrado. Emite un haz de luz rasante unidireccional. Posibilidad de montaje con o sin cajetín.

Встроенный спот из анодированного или окрашенного алюминия. С радиатором для отвода тепла. Круглый или квадратный. Узкий луч света в две стороны. Монтируется с монтажной коробкой или без нее.

6338 Tondo Monoemissione 0,03 kg

/WW Led max 2W 500 mA 199lm 3000K

/W Led max 2W 500 mA 209lm 4000K

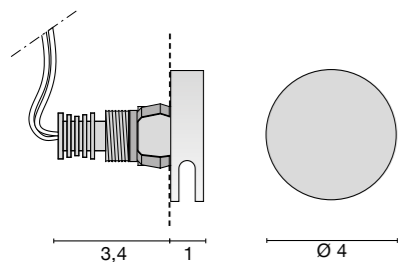

.01/WW .01/W .45/WW .45/W 2 cm.

6339 Quadrato Monoemissione 0,03 kg

/WW Led max 2W 500 mA 199lm 3000K

/W Led max 2W 500 mA 209lm 4000K

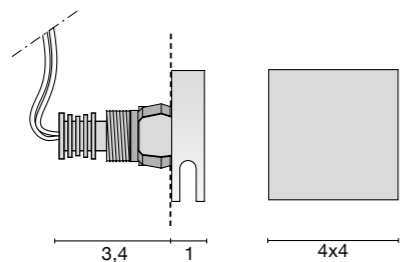

.01/WW .01/W .45/WW .45/W 2 cm.

Accessories



Drivers



TRIM

design: U.T. EGOLUCE



Faretto da incasso in alluminio anodizzato o verniciato bianco. Completo di dissipatore. Realizzato in versione tonda o quadrata con luce bidirezionale. Possibilità di montaggio con o senza cassaforma.

Spot encastré en aluminium, finition anodisé ou verni blanc. Dissipateur inclus. Disponible en Ronde ou carré. Emit un faisceau de lumière rasante bidirectionnel. Montage avec ou sans boîte d'encastrement.

Foco para empotrar en aluminio anodizado o pintado blanco. Disipador de calor incluido. Disponible en redondo y cuadrado. Emite un haz de luz rasante bidireccional. Posibilidad de montaje con o sin cajetín.

Recessed spotlight, white painted or anodized aluminium body. Heatsink included. Round or square version. Double side grazing light emission. Installation with or without junction box.

Einbaustrahler aus Aluminium eloxiert oder weiß lackiert. Verfügbar in Rund oder quadratisch. Inklusiv Kühlkörper. Streifende Lichtstrahlung auf zwei Seiten. Montage mit oder ohne Einbaugehäuse.

Встроенный спот из анодированного или окрашенного алюминия. С радиатором для отвода тепла. Круглый или квадратный. Узкий луч света в одну сторону. Монтируется с монтажной коробкой или без нее.

6336 Tondo Biemissione 0,03 kg

/WW Led max 2W 500 mA 199lm 3000K

/W Led max 2W 500 mA 209lm 4000K

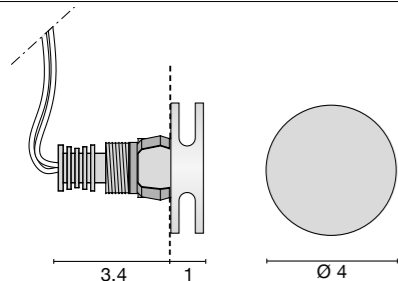
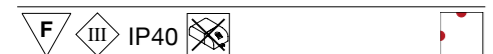

.01/WW .01/W .45/WW .45/W 2 cm.

6337 Quadrato Biemissione 0,03 kg

/WW Led max 2W 500 mA 199lm 3000K

/W Led max 2W 500 mA 209lm 4000K

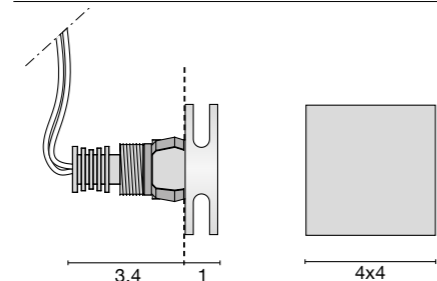

.01/WW .01/W .45/WW .45/W 2 cm.

Accessories



0212 Box + Plaster
0215 Plastic Box

Drivers



0125 350 mA (1-6 Trim) **0127** 500 mA (1-6 Trim) **0128** 350 mA (1-10 Trim) **0129** Dimmer **0129/DALI** Dimmer **0145** Dimmer Maxi **0145/DALI** Dimmer M.

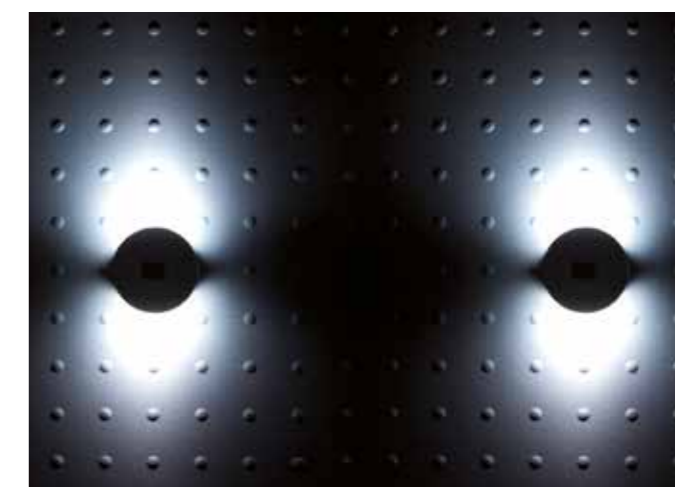

SPOON TONDO

design: U.T. EGOLUCE



Faretto da incasso a luce asimmetrica in alluminio anodizzato o verniciato bianco. Completo di dissipatore. Montaggio con cassaforma.
Versione ETL disponibile a richiesta

Spot encastré pour émission asymétrique en aluminium dans les finitions aluminium anodisé ou verni blanc. Dissipateur de chaleur inclus. Installation avec boîte d'encastrement.
Version ETL disponible sur demande

Foco para empotrar con luz asimétrica en aluminio anodizado o pintado blanco. Disipador de calor incluido. Montaje con cajetín.

Recessed spotlight for asymmetric emission. Aluminium frame in anodized or white finish. Heat sink included. Mounting with junction box.
ETL version available upon request

Einbaustrahler aus Aluminium für asymmetrische Ausstrahlung. Ausführung Alu eloxiert oder weiß lackiert. Inklusiv Kühlkörper. Montage mit Einbaugehäuse.

Встроенный светильник из анодированного или окрашенного в белый цвет алюминия. Ассиметричный луч света. С радиатором для отвода тепла. Монтируется с монтажной коробкой.

6350 0,1 kg

/WW Led max 2W 500 mA 199lm 3000K

/W Led max 2W 500 mA 209lm 4000K

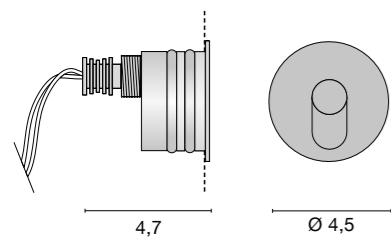

.01/WW .01/W .45/WW .45/W 3,8 cm.

Accessories



0214
Box + Plaster



0217
Plastic Box

Drivers



0125 350 mA
(1-6 Spoon)



0127 500 mA
(1-6 Spoon)



0128 350 mA
(1-10 Spoon)



0129 Dimmer
0129/DALI Dimmer



0145 Dimmer Maxi
0145/DALI Dimmer M.



SPOON QUADRO

design: U.T. EGOLUCE

Decorative Lights

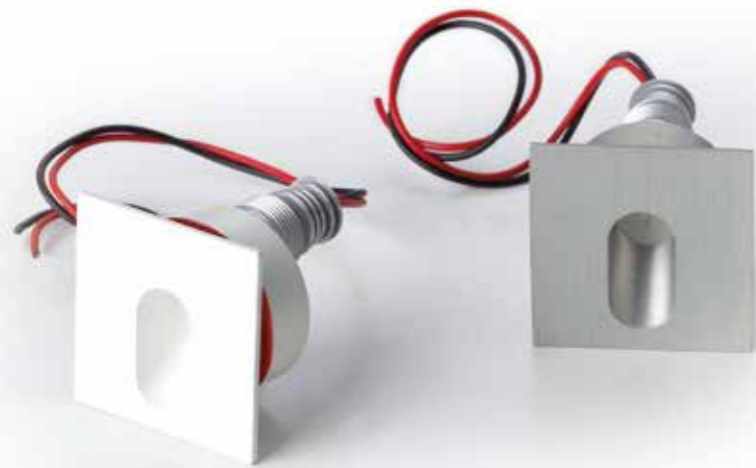

Faretto da incasso a luce asimmetrica in alluminio anodizzato o verniciato bianco. Completo di dissipatore. Montaggio con cassaforma.

Versione ETL disponibile a richiesta

Recessed spotlight for asymmetric emission. Aluminium frame in anodized or white finish. Heat sink included. Mounting with junction box.

ETL version available upon request

Spot encastré pour émission asymétrique en aluminium dans les finitions aluminium anodisé ou verni blanc. Dissipateur de chaleur inclus. Installation avec boîte d'encastrement.

Version ETL disponible sur demande

Einbaustrahler aus Aluminium für asymmetrische Ausstrahlung. Ausführung Alu eloxiert oder weiß lackiert. Inklusiv Kühlkörper. Montage mit Einbaugeschäube.

Foco para empotrar con luz asimétrica en aluminio anodizado o pintado blanco. Disipador de calor incluido. Montaje con cajetín.

Встроенный светильник из анодированного или окрашенного в белый цвет алюминия. Ассиметричный луч света. С радиатором для отвода тепла. Монтируется с монтажной коробкой.

6351 0,1 kg

/WW Led max 2W 500 mA 199lm 3000K

/W Led max 2W 500 mA 209lm 4000K

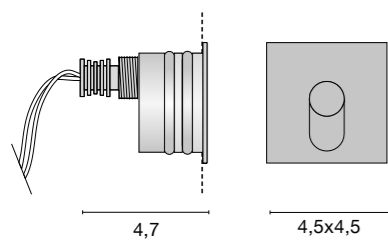
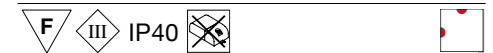

.01/WW .01/W .45/WW .45/W 3,8 cm.

Accessories



Drivers



Decorative Lights

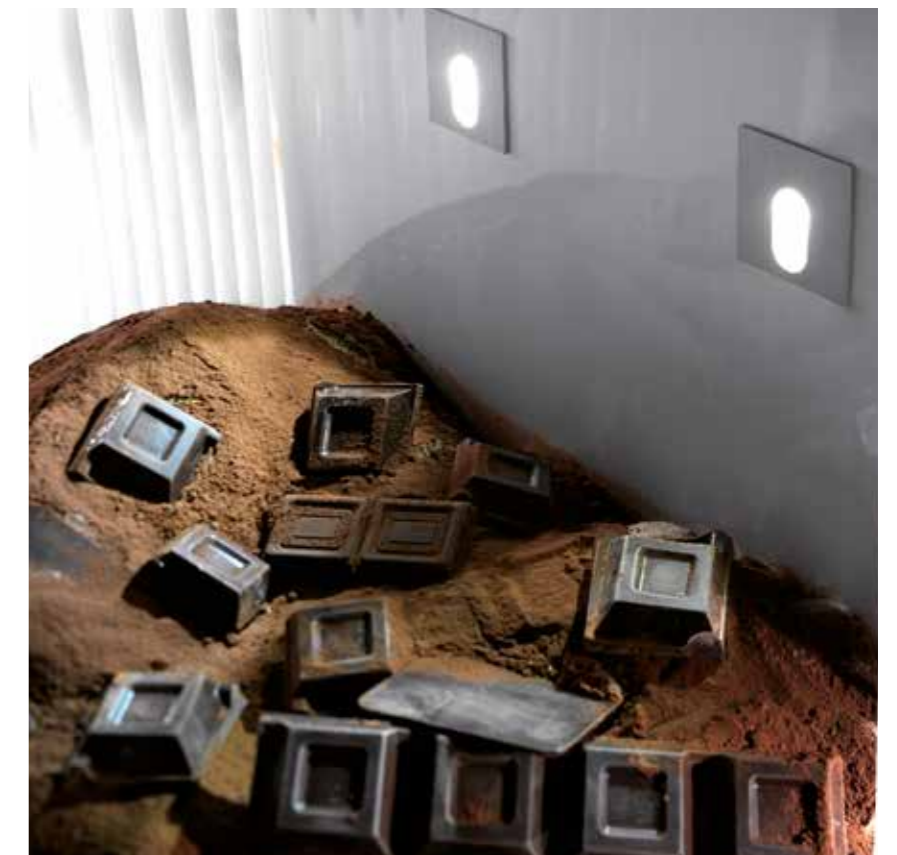

SLOT

design: U.T. EGOLUCE

Decorative Lights



Faretto da incasso a luce asimmetrica. Corpo in metallo verniciato bianco. Completo di dissipatore. Possibilità di montaggio con o senza cassaforma.

Versione ETL disponibile a richiesta

Recessed spotlight for asymmetric light, metal frame in white finish. Heatsink included. Mounting with or without junction box.

ETL version available upon request

Spot encastré pour lumière asymétrique, structure en métal blanc. Dissipateur de chaleur inclus. Prévu pour installation avec ou sans boîte d'encastrement.

Version ETL disponible sur demande

Einbaustrahler für asymmetrische Beleuchtung, Gestell aus Metall Ausführung weiß. Inklusiv Kühlkörper. Montage mit oder ohne Einbaugeschäule.

Foco empotrable con luz asimétrica, estructura en metal acabado blanco. Disipador de calor incluido. Posibilidad de montaje con o sin cajetín.

Встроенный светильник с асимметричным лучом, корпус из металла окрашенного в белый цвет. С радиатором для отвода тепла. Монтируется с монтажной коробкой или без нее.

6381 0,2kg

/WW Led 1W 350 mA 143lm 3000K

/W Led 1W 350 mA 151lm 4000K

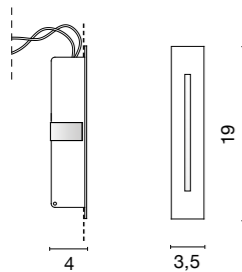

.01/WW .01/W 2,3x17 cm.

Accessories



0249
Box + Plaster

Drivers



0125 350 mA
(1-6 Slot)



0128 350 mA
(1-10 Slot)



0129 Dimmer
0129/DALI Dimmer



0145 Dimmer Maxi
0145/DALI Dimmer M.

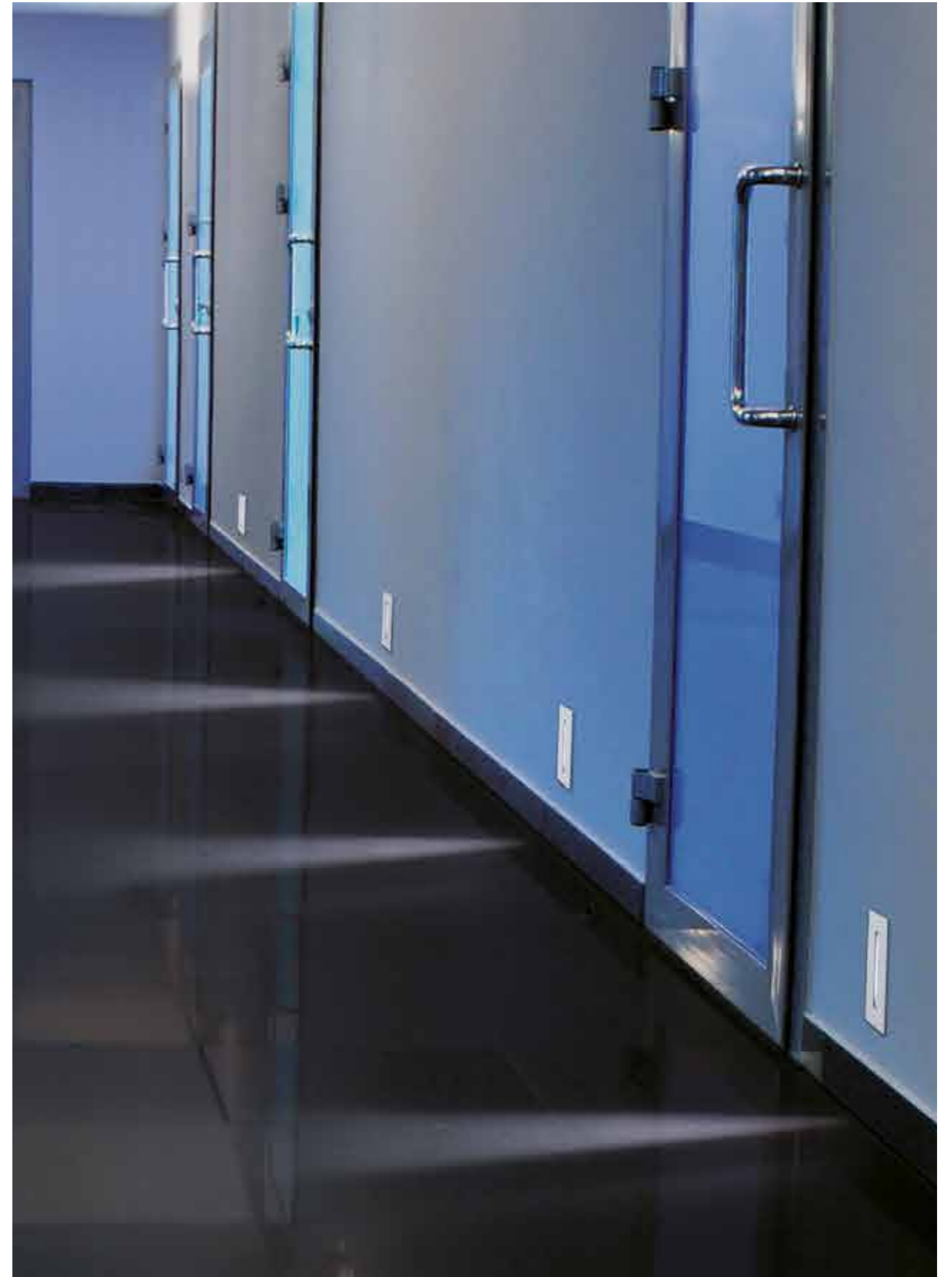

Decorative Lights

Square

EASY QUADRO	p. 336
DISSY QUADRO	p. 340
EDY MINI	p. 344
EDY	p. 346
DELTA MINI LED	p. 350
DELTA LED	p. 352
VERO QUADRO	p. 354
VERO QUADRO ORIENT.	p. 358
6048	p. 360
6056	p. 361
MODUS	p. 362
MODUS LED	p. 362

Round

EASY TONDO	p. 364	PINCO COB	p. 396
DISSY TONDO	p. 368	OKKIO	p. 398
TAPPO MINI	p. 372	OKKIO LED	p. 398
TAPPO	p. 374	ZEN	p. 400
TAPPO MAXI	p. 378	ZEN LED	p. 400
TAPPO ORIENTABILE	p. 380	6204	p. 402
VERO TONDO	p. 386	6239	p. 402
VERO TONDO ORIENT.	p. 388	6240	p. 402
VENTITRE'	p. 390	GAMMA	p. 403
6447	p. 392	EOS PIU'	p. 403
6455	p. 393	FRIDA	p. 403
GEKO LED	p. 394	6024	p. 404
GEKO	p. 395	6028	p. 404
ZIC	p. 396	6030	p. 404

SPOTS

EASY QUADRO

design: U.T. EGOLUCE

Spots



Faretto da incasso minitrim in metallo verniciato bianco con sorgente arretrata per diverse sorgenti luminose.

Minitrim spots with recessed light source in white finished metal for a wide range of light sources.

Spots minitrim à encastrer en métal verni blanc avec source reculée, pour utilisation avec plusieurs sources lumineuses.

Minitrim Einbaustrahler mit zurückgestellten Lichtquellen, Körper aus Weiß lackiertem Metall, mit vielen Lichtquellen

Focos empotrables minitrim con fuente de luz puesta arriba, cuerpo de metal pintado blanco, para diferentes fuentes de luz.

Встроенный спот с тонкой рамкой из окрашенного в белый цвет металла с углубленными разными источниками света



EASY QUADRO COB LED - MODULO POWER LED

design: U.T. EGOLUCE

EASY QUADRO 12V-230V

design: U.T. EGOLUCE

Spots

Spots



6431 + COB LED 0,40 kg

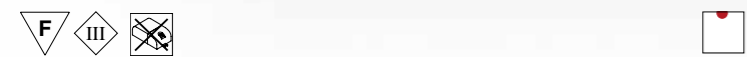

.01 7x7cm.

Source LED cod.	OPTIC degree		Im	LED color
0107/XW	124 140 160	6,2W 17,8V 350mA	740lm	2700K
0107/WW	124 140 160	6,2W 17,8V 350mA	785lm	3000K
0107/W	124 140 160	6,2W 17,8V 350mA	829lm	4000K
0107/CW	124 140 160	6,2W 17,8V 350mA	850lm	5000K
0108/XW	124 140 160	9,2W 18,4V 500mA	995lm	2700K
0108/WW	124 140 160	9,2W 18,4V 500mA	1056lm	3000K
0108/W	124 140 160	9,2W 18,4V 500mA	1115lm	4000K
0108/CW	124 140 160	9,2W 18,4V 500mA	1160lm	5000K
0108/WW/IP	38	9,2W 18,4V 500mA	1056lm	3000K
0108/W/IP	38	9,2W 18,4V 500mA	1115lm	4000K

6431 + POWER LED 0,40 kg

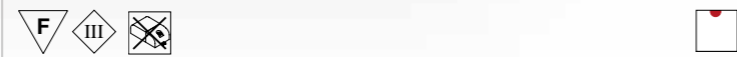

.01 7x7cm.

Source LED cod.	OPTIC degree		Im	LED color
0121	25°	3x3W 700mA	846lm	4000K
0123	25°	3x3W 700mA	804lm	3000K

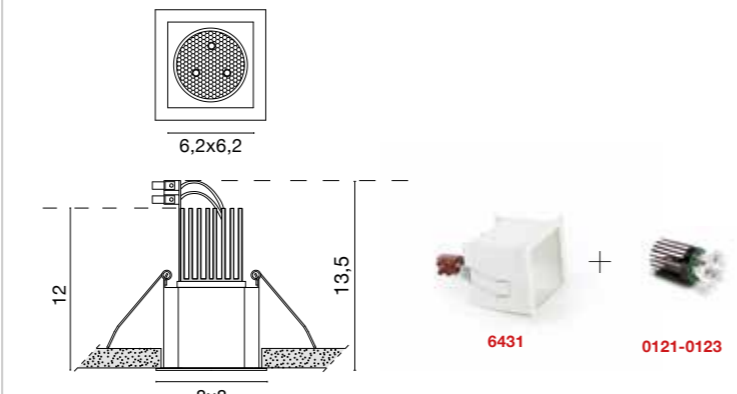
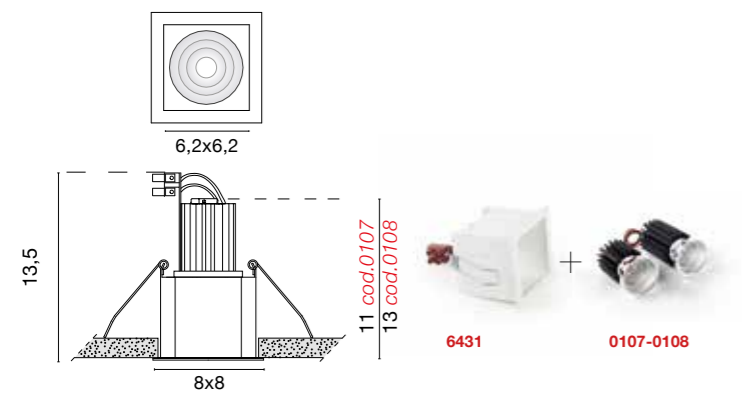

Source LED	Drivers	0125	0126	0147/COB	0128	0129	0129/DALI	0145	0145/DALI	0115/EM
		350mA	700mA	500mA	350mA	DIM	DIM DALI	DIM	DIM DALI	EMERGENCY
0107	1	NO	NO	NO	1-2	1-2	1-2	1-3	1-3	1
0108	NO	NO	NO	NO	1-2	1-2	1-2	1-3	1-3	1
0121	1-2	1-2	NO	NO	1-3	1-3	1-4	1-6	1-6	NO
0123	1-2	1-2	NO	NO	1-3	1-3	1-4	1-6	1-6	NO

Accessories



0288.01
Schermo in metacrilato satinato
Satin methacrylate screen

6430 12V 0,2 kg

12V 50W GU5,3



.01

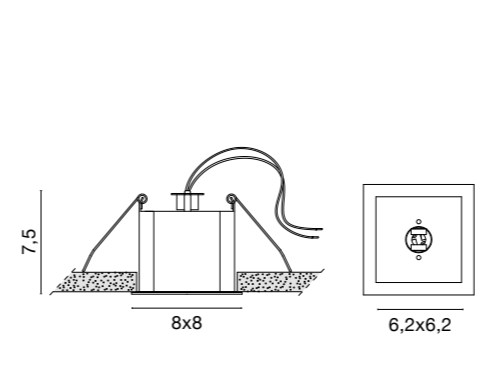

.01 7x7cm.

Accessories



0288.01
Schermo in metacrilato satinato solo per GU10 Led
Satin methacrylate screen only for GU 10 Led

6432 230V 0,2 kg

50W GU10

7W GU10 LED (cod.0104/16)

7W GU10 LED (cod.0094/16)



.01

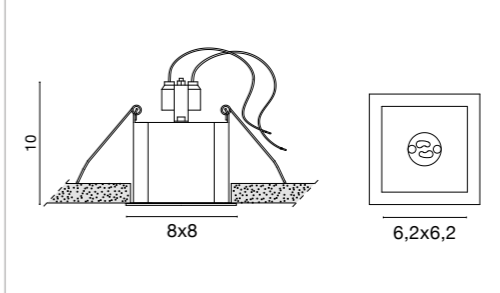

.01 7x7cm.

Accessories



0288.01
Schermo in metacrilato satinato solo per GU10 Led
Satin methacrylate screen only for GU 10 Led

DISSY QUADRO

design: U.T. EGOLUCE

Spots



Faretto da incasso in alluminio con cornice in diverse finiture. Led COB con lente trasparente (/TR) o satinata (/ST).
A richiesta sono fornibili anche altre tonalità di luce (2700K, 4000K) o fasci di apertura (24°-58°).

Aluminium spot with frame in different finishing. Led COB with transparent (/TR) or satin (/ST) lens.
Other light tones (2700K, 4000K) and beam angles (24° - 58°) can be supplied on request.

Spot à encastrer en aluminium avec cadre en plusieurs finitions. Led COB avec lentilles transparent (/TR) ou satinée (/ST).
D'autres tonalités de lumière (2700, 4000K) et faisceaux (24°-58°) sont disponibles à la demande.

Einbaustrahler aus Aluminium, mit vielen verschiedenen Rahmenausfertigungen, COB Led mit klarglass (/TR) oder satiniert (/ST).
Auf und Anfrage sind andere Lichtonen (2700, 4000K) oder Abstrahlwinkel (24°-58°) verwendbar.

Foco empotrable en aluminio con marco en acabados variados. Led COB con lentilla transparente (/TR) o satinada (/ST).
A pedido se realizan aparatos con otras temperaturas de luz, (2700, 4000K), y hazes de luz (24°-58°).

Встроенный spot из металла в разных отделках. Светодиод COB (COB = Chip On Board = светодиоды на плате) с прозрачной (/TR) или матовой (/ST) линзой.
Светильники с другой цветовой температурой (2700K или 4000K) и двумя лучами (24-58 градусов) могут быть изготовлены по запросу.

6409 0,3 kg
9,2W 18,4V 500mA 1056lm CRI>80 3000K
F III IP44

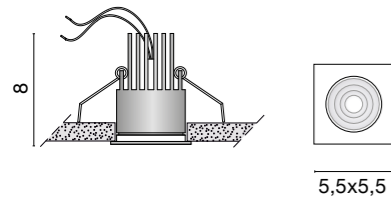

.01 .02 .03 .21 .31 .32 5 cm.

Options
/ST Con vetro satinato - Satin glass
/TR Con vetro trasparente - Clear glass

Drivers



0125 350 mA (1 Dissy) 0128 350 mA (1-2 Dissy) 0129 Dimmer 0129/DALI Dimmer 0145 Dimmer Maxi 0145/DALI Dimmer M. 0147/COB (1-2 Dissy) 0115/EM Emergency Unit

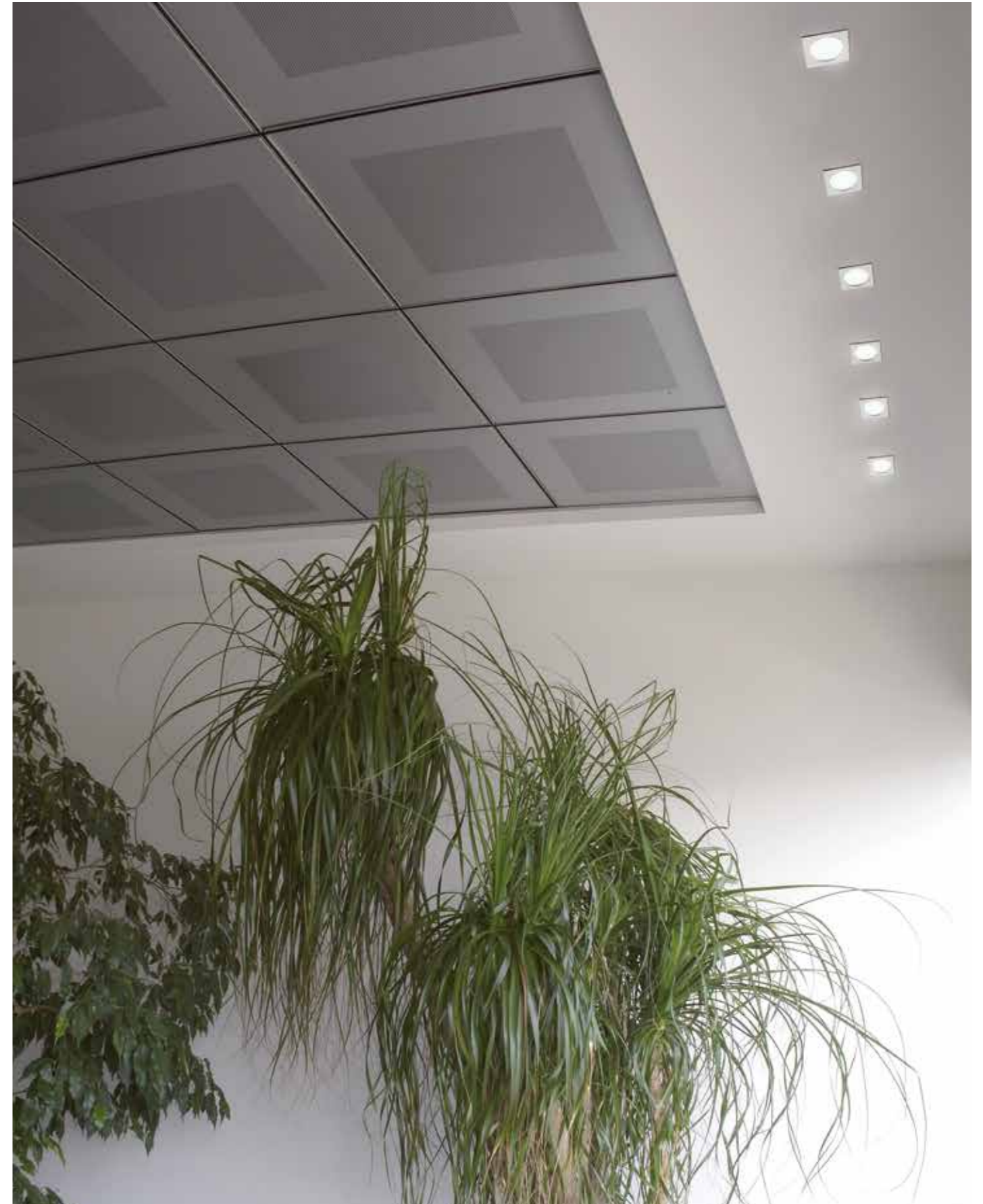
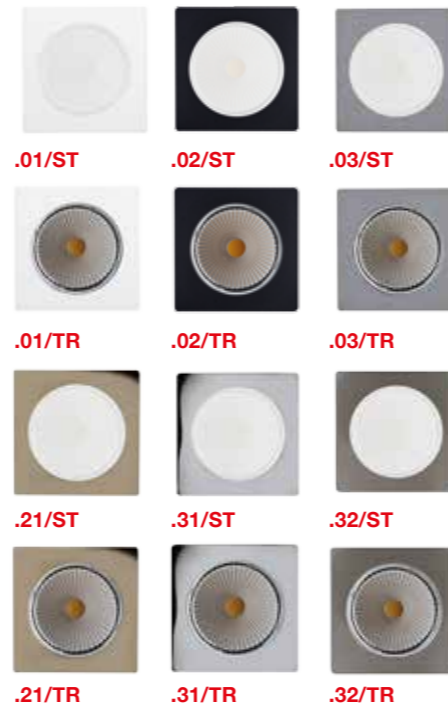

EDY - EDY MINI

design: U.T. EGOLUCE

Spots



Faretti da incasso in metallo. Cornice cromata, nichelata, verniciata bianca o grigia. Possibilità di montaggio con o senza casseforme.

Recessed spotlights, metal body and frame. Available in chrome, nickel matt, lacquered white or grey. Mounting with or without junction box.

Spot encastrés en métal. Cadre en métal chromé, nickel mat, verni blanc ou gris. Prévu pour installation avec ou sans boîte d'encastrement.

Einbaustrahleren aus Metall. Rahmen: verchromt, Nickel matt, lackiert weiß oder grau. Montage mit oder ohne Einbaugehäuse.

Focos para empotrar en metal. Marco cromado, niquelado, pintado blanco o gris. Posibilidad de montaje con o sin cajetín.

Встроенный спот из металла с рамкой хромированной, никелированной, окрашенной в белый или серый цвет. С радиатором для отвода тепла. Монтируется с монтажной коробкой или без нее.

Spots

EDY MINI

design: U.T. EGOLUCE

Spots



6298 edy mini 0,1 kg

/ww max 2W 500mA 199lm 3000K

/w max 2W 500mA 209lm 4000K

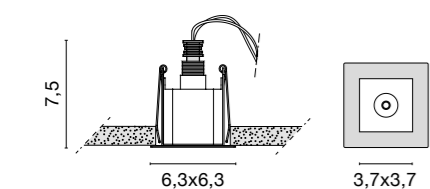

.01/W .01/WW .03/W .03/WW
.31/W .31/WW .32/W .32/WW

5,2x5,2cm.

6299 edy mini 45° 0,1 kg

/ww max 2W 500mA 199lm 3000K

/w max 2W 500mA 209lm 4000K

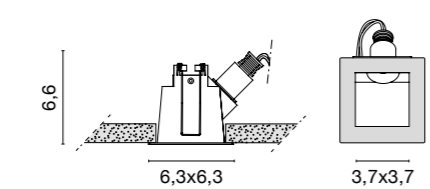

.01/W .01/WW .03/W .03/WW
.31/W .31/WW .32/W .32/WW

5,2x5,2cm.

Accessories



Art. 0218
Cassaforma per calcestruzzo
Wallbox for concrete
11x11x9h



Art. 0219
Piastra per muratura
Plaster kit

Drivers



0125 350 mA
(1-6 Edy Mini)



0127 500 mA
(1-6 Edy Mini)



0128 350 mA
(1-10 Edy Mini)



0129 Dimmer
0129/DALI Dimmer



0145 Dimmer Maxi
0145/DALI Dimmer M.



EDY COB LED - MODULO POWER LED

design: U.T. EGOLUCE

EDY 12V / 230V

design: U.T. EGOLUCE



6305 + COB LED 0,40 kg

F III

.01 .03 .31 .32 7,2x8,2cm.

Source LED cod.	OPTIC degree		lm	LED color
0107/XW	124 140 160	6,2W 17,8V 350mA	740lm	2700K
0107/WW	124 140 160	6,2W 17,8V 350mA	785lm	3000K
0107/W	124 140 160	6,2W 17,8V 350mA	829lm	4000K
0107/CW	124 140 160	6,2W 17,8V 350mA	850lm	5000K
0108/XW	124 140 160	9,2W 18,4V 500mA	995lm	2700K
0108/WW	124 140 160	9,2W 18,4V 500mA	1056lm	3000K
0108/W	124 140 160	9,2W 18,4V 500mA	1115lm	4000K
0108/CW	124 140 160	9,2W 18,4V 500mA	1160lm	5000K
0108/WW/IP	38	9,2W 18,4V 500mA	1056lm	3000K
0108/W/IP	38	9,2W 18,4V 500mA	1115lm	4000K

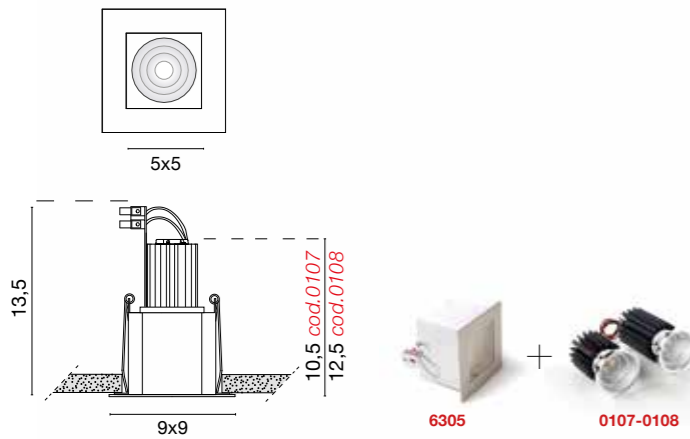

6305 + POWER LED 0,40 kg

F III

.01 .03 .31 .32 7,2x8,2cm.

Source LED cod.	OPTIC degree		lm	LED color
0121	25°	3x3W 700mA	846lm	4000K
0123	25°	3x3W 700mA	804lm	3000K

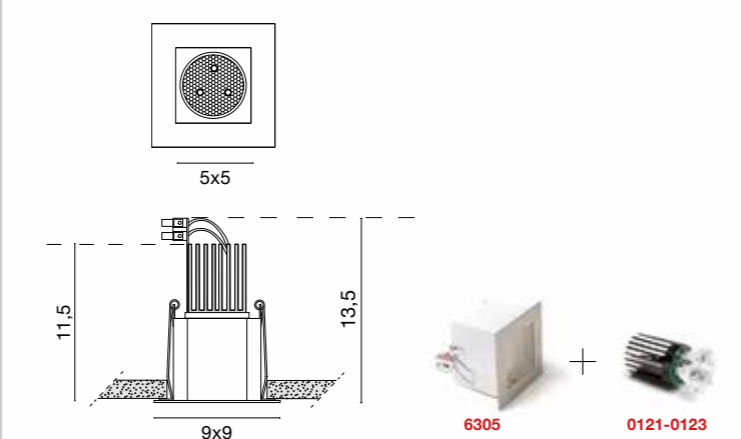

Source LED	Drivers	0126	0147/COB	0128	0129	0129/DALI	0145	0145/DALI	0115/EM
		350mA	500mA	350mA	DIM	DIM DALI	DIM	DIM DALI	EMERGENCY
0107	1	NO	NO	1-2	1-2	1-2	1-3	1-3	1
0108	NO	NO	1-2	NO	1-2	1-2	1-3	1-3	1
0121	1-2	1-2	NO	1-3	1-3	1-4	1-6	1-6	NO
0123	1-2	1-2	NO	1-3	1-3	1-4	1-6	1-6	NO

Accessories



6300 12V 0,3 kg

12V 50W GU5,3

III 0,3m

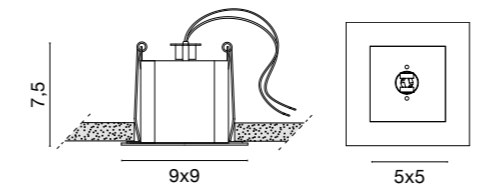

.01 .03 .31 .32 7,2x8,2cm.

6302 230V 0,3 kg

50W GU10

7W GU10 LED (cod.0104/16)

7W GU10 LED (cod.0094/16)

0,3m

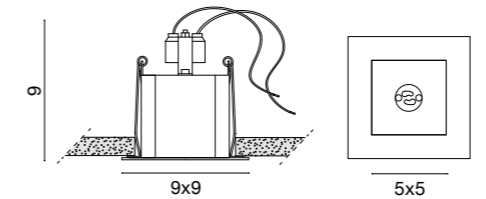

.01 .03 .31 .32 7,2x8,2cm.

Accessories



6301 12V edy 45° 0,3 kg

12V 35W GU4

12V 20W GU4 F

III 0,3m

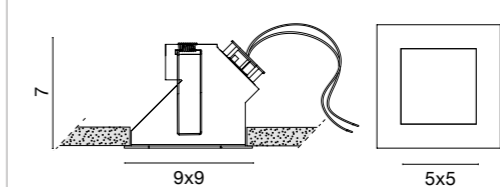

.01 .03 .31 .32 7,2x8,2cm.

6303 230V edy 45° 0,3 kg

20W G9 ECO

0,3m

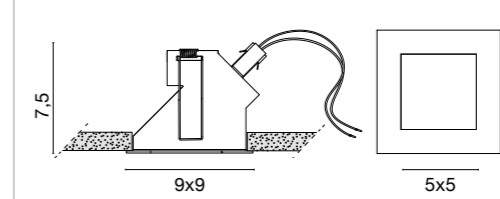

.01 .03 .31 .32 7,2x8,2cm.



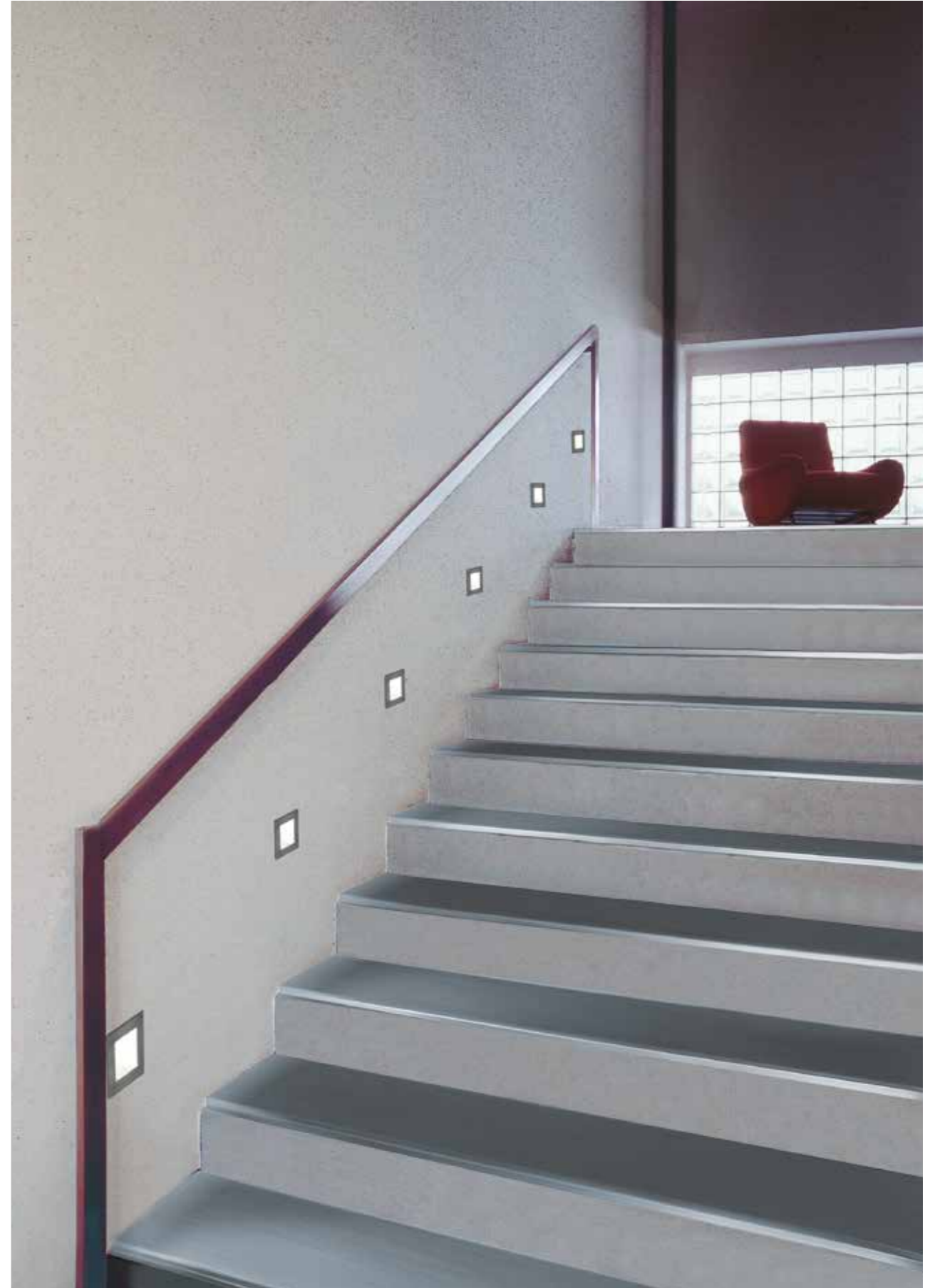

DELTA MINI LED

design: U.T. EGOLUCE

Spots



6492 delta mini 1,5 kg

/WW Led 10,5W 1430lm 3000K

/W Led 10,5W 1430lm 4000K

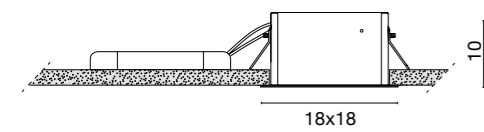

.01/W .01/WW .03/W .03/WW 15,6x16,6cm.
.31/W .31/WW .32/W .32/WW

6492 delta mini DIMM DALI 1,5 kg

/WW Led 10,5W 1430lm 3000K

/W Led 10,5W 1430lm 4000K

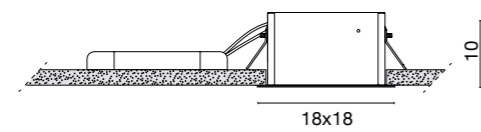
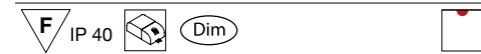

.01/W/DALI .01/WW/DALI 15,6x16,6cm.
.03/W/DALI .03/WW/DALI
.31/W/DALI .31/WW/DALI
.32/W/DALI .32/WW/DALI

6492 delta mini DIMM 1...10V 1,5 kg

/WW Led 10,5W 1430lm 3000K

/W Led 10,5W 1430lm 4000K

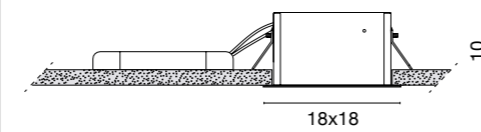
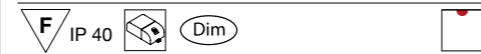

.01/W/DIM .01/WW/DIM 15,6x16,6cm.
.03/W/DIM .03/WW/DIM
.31/W/DIM .31/WW/DIM
.32/W/DIM .32/WW/DIM

Drivers



0115/EM
Emergency Unit

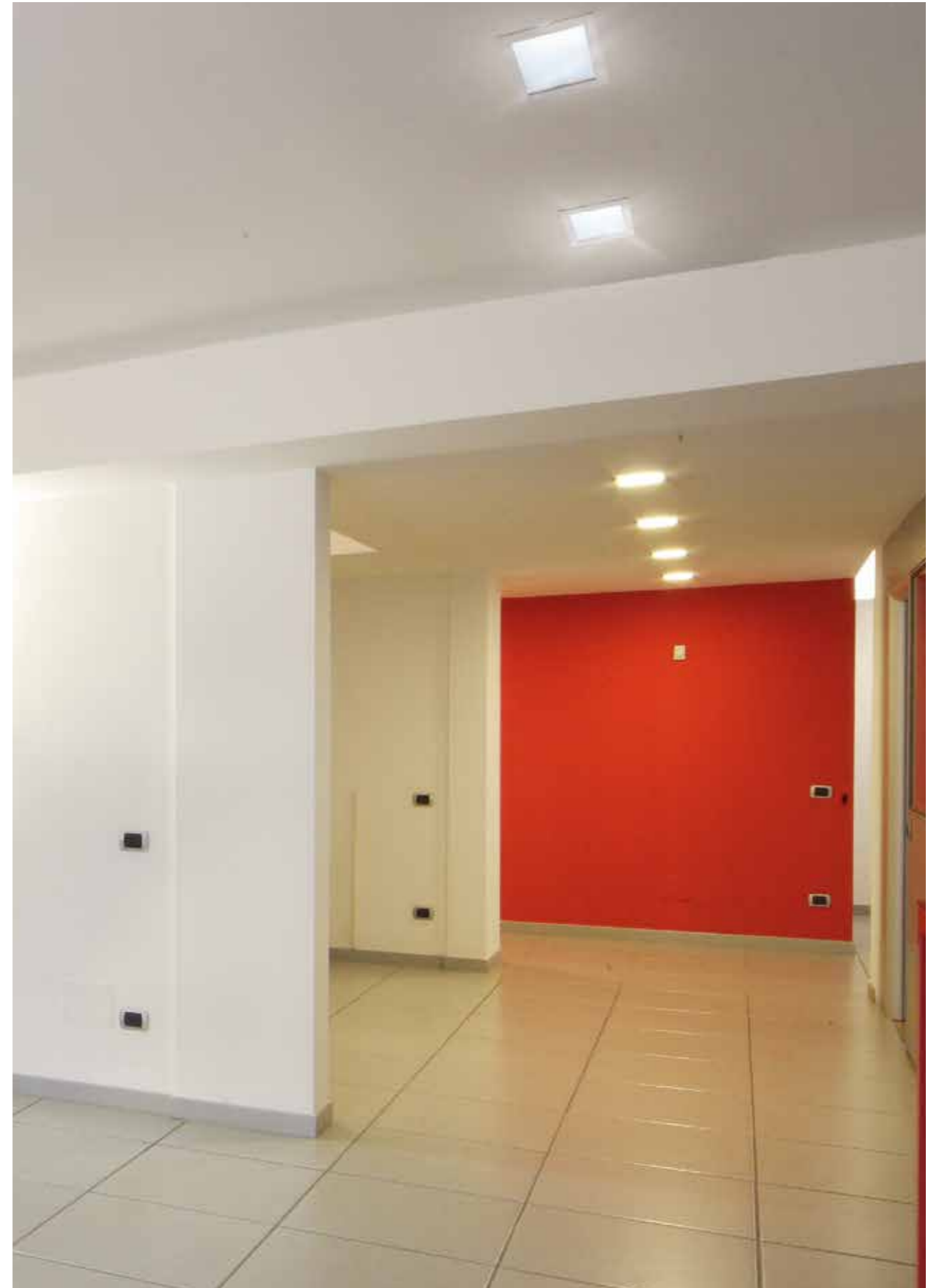

Spots



6493 delta 2 kg

/WW Led 15,5W 1950lm 3000K

/W Led 15,5W 1950lm 4000K

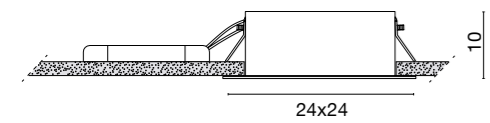

.01/W .01/WW .03/W .03/WW 20,5x20,5cm.
.31/W .31/WW .32/W .32/WW

6493 delta DIMM DALI 2 kg

/WW Led 15,5W 1950lm 3000K

/W Led 15,5W 1950lm 4000K

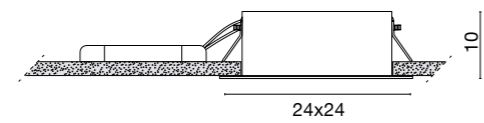
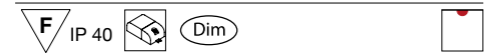

.01/W/DALI .01/WW/DALI 20,5x20,5cm.
.03/W/DALI .03/WW/DALI
.31/W/DALI .31/WW/DALI
.32/W/DALI .32/WW/DALI

6493 delta DIMM 1...10V 2 kg

/WW Led 15,5W 1950lm 3000K

/W Led 15,5W 1950lm 4000K

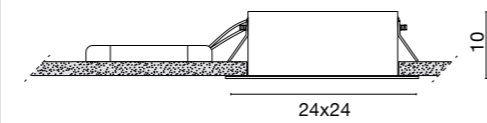
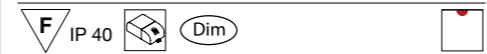

.01/W/DIM .01/WW/DIM 20,5x20,5cm.
.03/W/DIM .03/WW/DIM
.31/W/DIM .31/WW/DIM
.32/W/DIM .32/WW/DIM

Drivers



0115/EM
Emergency Unit

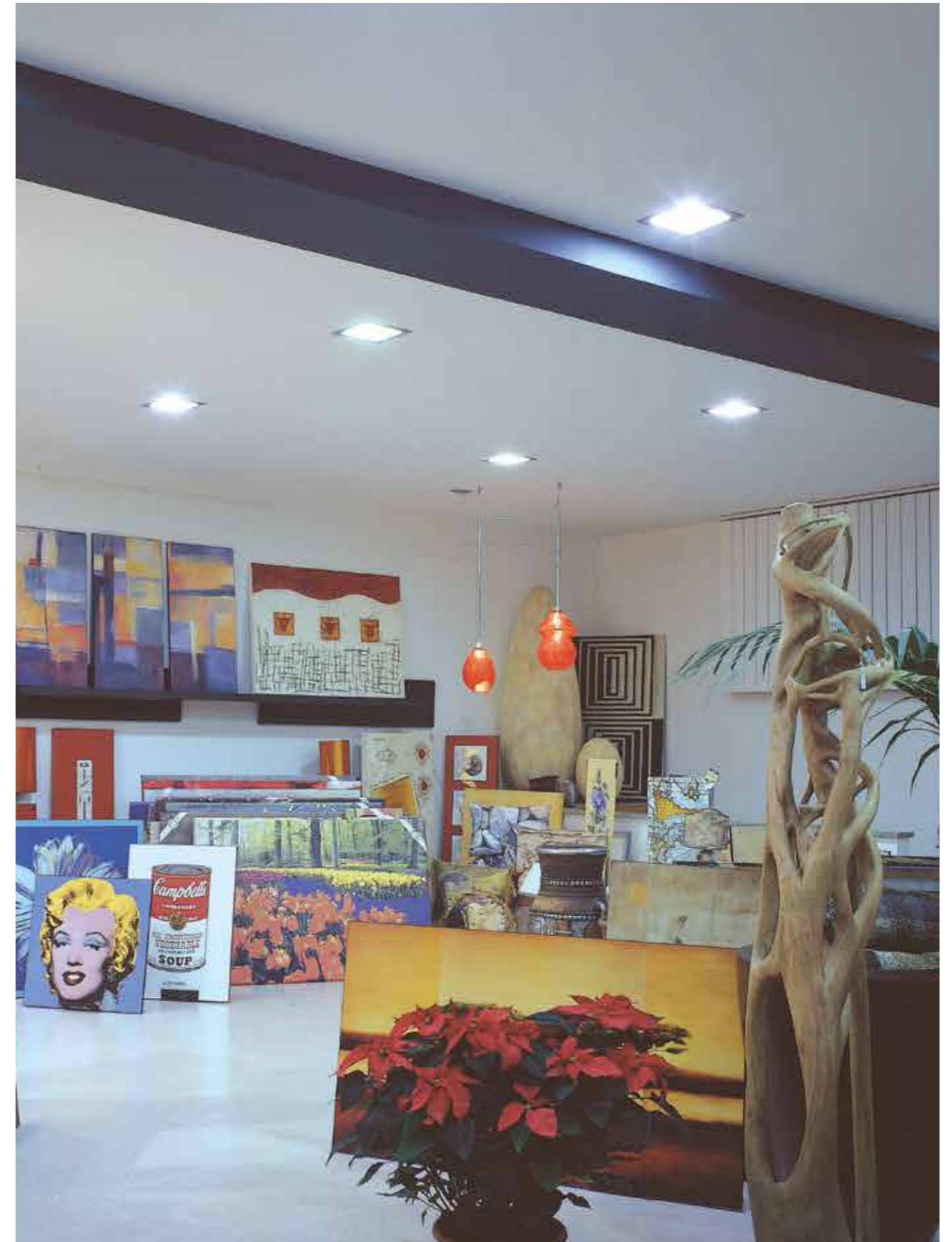

VERO QUADRO

design: U.T. EGOLUCE

Spots



Faretti da incasso minitrim con sorgente arretrata, corpo in pressofusione d'alluminio verniciati bianchi, realizzati in 3 misure per consentire l'utilizzo di vari COB led

Minitrim spots with recessed light source, body in white coated die cast aluminum, 3 sizes available to fit a range of COB led.

Spots minitrim à encastrer avec source reculée, corps en aluminium injecté vernis blanc, disponibles en 3 tailles pour utilisation de plusieurs COB led.

Minitrim Einbaustrahler mit zurückgestellten Lichtquellen, Körper aus Weiß lackiertem Aluminium Pressguss. Die 3 verfügbaren Durchmesser ermöglichen die Benutzung von verschiedenen COB Lichtquellen.

Focos empotrables minitrim con fuente de luz puesta arriba, cuerpo en presofusion de aluminio pintado blanco. Los 3 tamaños disponibles permiten el uso de diferentes COB led.

Встроенный спот с тонкой рамкой, корпус из литого под давлением алюминия, окрашенного в белый цвет, в 3-х размерах, с углубленными разными источниками света.

VERO QUADRO

design: U.T. EGOLUCE

Spots



6426 vero mini quadro 0,35 kg

ww 13,8W 27,6V 500mA 1649lm CRI>80 3000K/58°

w 13,8W 27,6V 500mA 1741lm CRI>80 4000K/58°

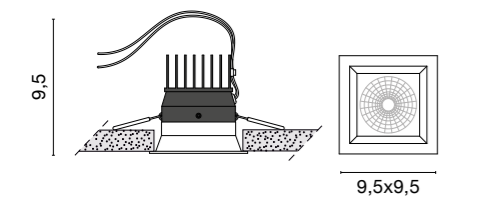
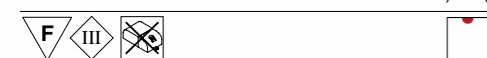

.01/W .01/WW 8,5x8,5 cm.

6427 vero quadro 0,7 kg

ww 16,2W 32,3V 500mA 2120lm CRI>80 3000K/50°

w 16,2W 32,3V 500mA 2200lm CRI>80 4000K/50°

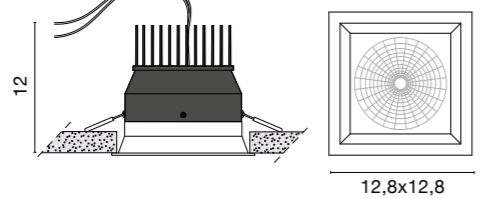
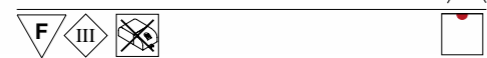

.01/W .01/WW 11,5x11,5 cm.

6428 vero maxi quadro 1 kg

ww 23,4W 33,4V 700mA 2813lm CRI>80 3000K/45°

w 23,4W 33,4V 700mA 2919lm CRI>80 4000K/45°

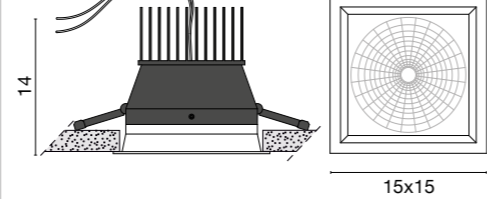

.01/W .01/WW 14x14 cm.

Options

/ST Con diffusore in metacrilato satinato - With satin methacrylate diffuser

/P Protezione IP44 della parte esposta - Exposed part protection IP44

	Drivers							
	0169	0147/COB	0148/COB	0129	0129/DALI	0145	0145/DALI	0115/EM
	Driver multipower	500mA	700mA	DIM	DIM DALI	DIM	DIM DALI	EMERGENCY
6426	1	1	NO	1	1	1-2	1-2	1
6427	1	1	NO	1	1	1-2	1-2	1
6428	1	NO	1	1	1	1-2	1-2	1



Spots

VERO QUADRO ORIENTABILE

design: U.T. EGOLUCE

Spots



6429 0,85 kg



.01 14x14 cm.

Source LED cod.	OPTIC degree	Im	LED color
/WW	/30 /55	23,4W 33,4V 700mA CRI>80 2813lm	3000K
/W	/30 /55	23,4W 33,4V 700mA CRI>80 2919lm	4000K

Options
/ST Con diffusore in metacrilato satinato - With satin methacrylate diffuser

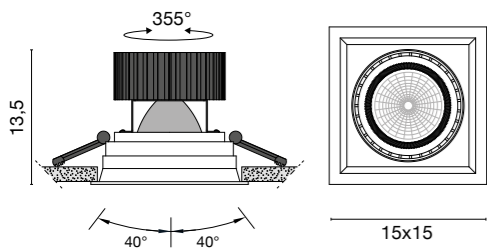

Drivers		0148/COB	0129	0129/DALI	0145	0145/DALI	0115/EM
		700mA	DIM	DIM	DIM	DALI	EMERGENCY
6429	1	1	1	1	1-2	1-2	1

6048 COB LED - MODULO POWER LED

design: U.T. EGOLUCE

Spots

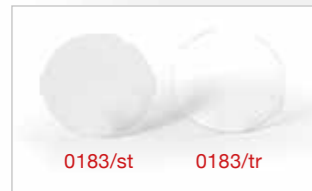
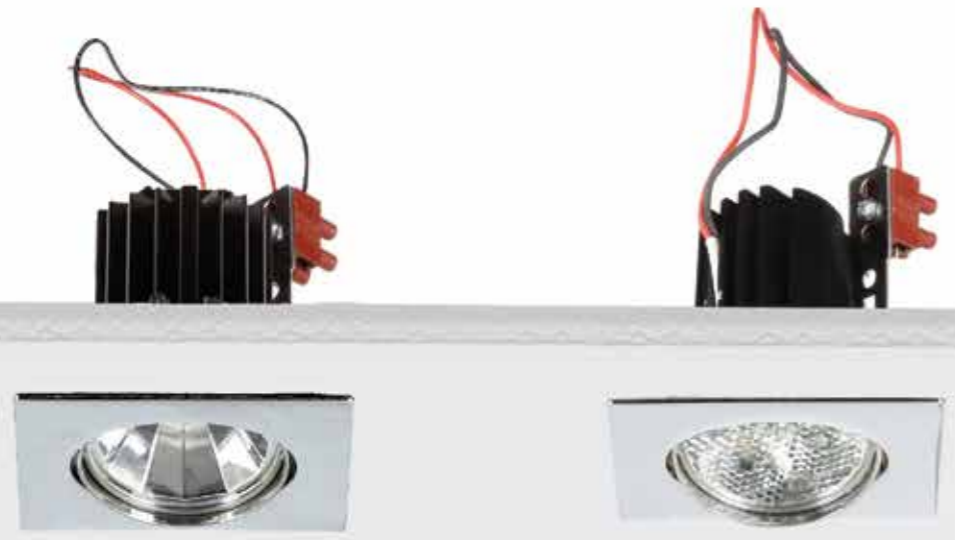

Dischetto reggi lampadina pag 449
Bulb stopper pg 449

6048 + COB LED

0,40 kg



.01 .31 .32

7,5 cm.

Source LED cod.	OPTIC degree		lm	LED color
0107/XW	124 140 160	6,2W 17,8V 350mA	740lm	2700K
0107/WW	124 140 160	6,2W 17,8V 350mA	785lm	3000K
0107/W	124 140 160	6,2W 17,8V 350mA	829lm	4000K
0107/CW	124 140 160	6,2W 17,8V 350mA	850lm	5000K
0108/XW	124 140 160	9,2W 18,4V 500mA	995lm	2700K
0108/WW	124 140 160	9,2W 18,4V 500mA	1056lm	3000K
0108/W	124 140 160	9,2W 18,4V 500mA	1115lm	4000K
0108/CW	124 140 160	9,2W 18,4V 500mA	1160lm	5000K
0108/WW/IP	38	9,2W 18,4V 500mA	1056lm	3000K
0108/W/IP	38	9,2W 18,4V 500mA	1115lm	4000K

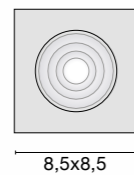
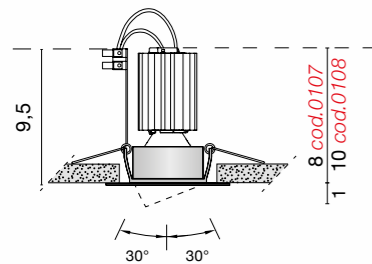

6048 + POWER LED

0,40 kg

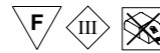

.01 .31 .32

7,5 cm.

Source LED cod.	OPTIC degree		lm	LED color
0121	25°	3x3W 700mA	846lm	4000K
0123	25°	3x3W 700mA	804lm	3000K

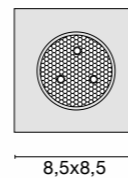
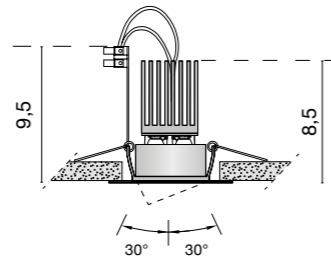

Source LED	Drivers								
	0125 350mA	0126 700mA	0147/COB 500mA	0128 350mA	0129 DIM	0129/DALI DIM DALI	0145 DIM	0145/DALI DIM DALI	0115/EM EMERGENCY
0107	1	NO	NO	1-2	1-2	1-2	1-3	1-3	1
0108	NO	NO	1-2	NO	1-2	1-2	1-3	1-3	1
0121	1-2	1-2	NO	1-3	1-3	1-4	1-6	1-6	NO
0123	1-2	1-2	NO	1-3	1-3	1-4	1-6	1-6	NO

6048

design: U.T. EGOLUCE

Spots



6048 12V

0,1 kg

12V 50W GU5,3

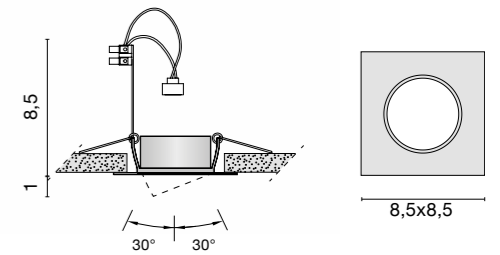
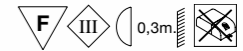

.01 .31 .32

7,5 cm.

6056

design: U.T. EGOLUCE

Spots



6056 230V

0,15 kg

50W GU10

7W GU10 LED (cod.0104/16)

7W GU10 LED (cod.0094/16)

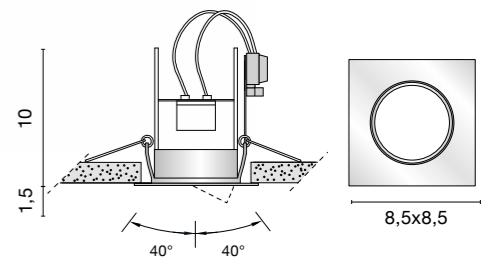
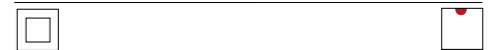

.01 .31 .32

7,5 cm.

MODUS

design: U.T. EGOLUCE

Spots



6265 0,07 kg

12V 20W G4 



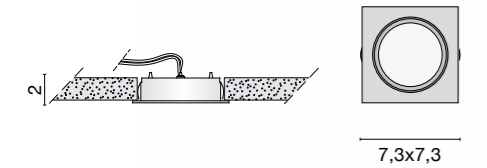

.01 .21 .31 .32  6 cm.

MODUS LED

design: U.T. EGOLUCE

Spots



6398 0,08 kg

\varnothing WW max 2W 500mA 199lm 3000K 

\varnothing W max 2W 500mA 209lm 4000K 



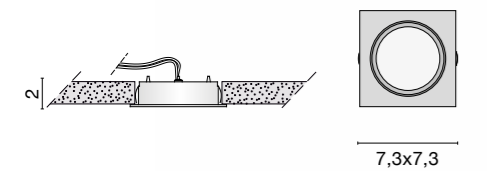

.01/W .01/WW .21/W .21/WW
.31/W .31/WW .32/W .32/WW  6 cm.

Drivers



0125 350 mA (1-6 Modus) **0127** 500 mA (1-6 Modus) **0128** 350 mA (1-10 Modus) **0129** Dimmer **0145** Dimmer Maxi
0129/DALI Dimmer **0145/DALI** Dimmer M.

Accessories



0232
Cassaforma da parete
Wall Plastic Box
Only for 6398



Spots

EASY TONDO

design: U.T. EGOLUCE

Spots



Faretto da incasso minitrim in metallo verniciato bianco con sorgente arretrata per diverse sorgenti luminose.

Minitrim spots with recessed light source in white finished metal for a wide range of light sources.

Spots minitrim à encastrer en métal verni blanc avec source reculée, pour utilisation avec plusieurs sources lumineuses.

Minitrim Einbaustrahler mit zurückgestellten Lichtquellen, Körper aus Weiß lackiertem Metall, mit vielen Lichtquellen

Focos empotrables minitrim con fuente de luz puesta arriba, cuerpo de metal pintado blanco, para diferentes fuentes de luz.

Встроенный спот с тонкой рамкой из окрашенного в белый цвет металла с углубленными разными источниками света



Spots

EASY TONDO COB LED - MODULO POWER LED

design: U.T. EGOLUCE

EASY TONDO 12V-230V

design: U.T. EGOLUCE

Spots

Spots

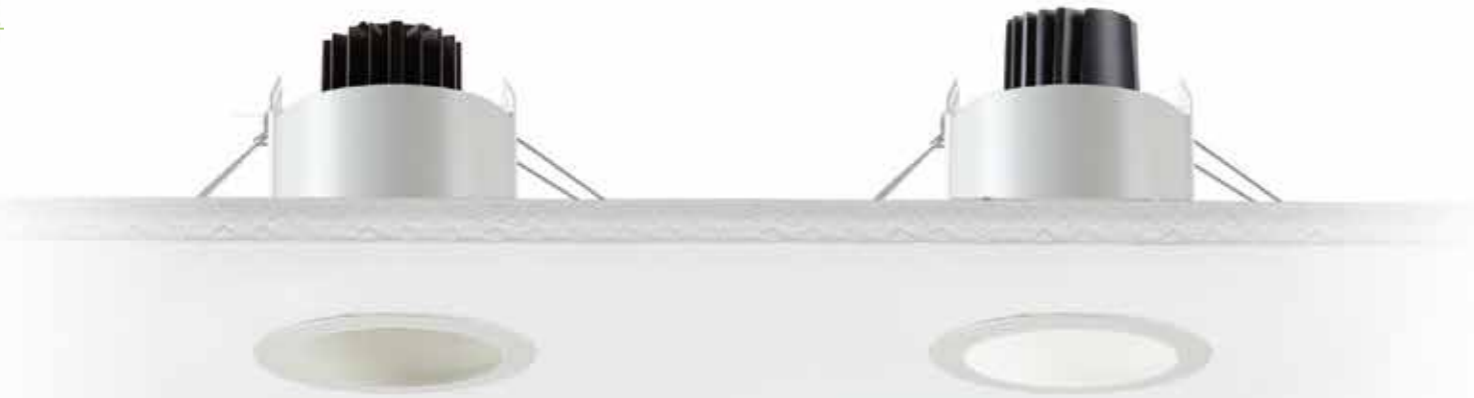

6441 + COB LED 0,40 kg

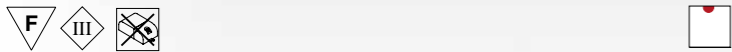

.01 Ø 8,6 cm.

Source LED cod.	OPTIC degree		lm	LED color
0107/XW	124 140 160	6,2W 17,8V 350mA	740lm	2700K
0107/WW	124 140 160	6,2W 17,8V 350mA	785lm	3000K
0107/W	124 140 160	6,2W 17,8V 350mA	829lm	4000K
0107/CW	124 140 160	6,2W 17,8V 350mA	850lm	5000K
0108/XW	124 140 160	9,2W 18,4V 500mA	995lm	2700K
0108/WW	124 140 160	9,2W 18,4V 500mA	1056lm	3000K
0108/W	124 140 160	9,2W 18,4V 500mA	1115lm	4000K
0108/CW	124 140 160	9,2W 18,4V 500mA	1160lm	5000K
0108/WW/IP	38	9,2W 18,4V 500mA	1056lm	3000K
0108/W/IP	38	9,2W 18,4V 500mA	1115lm	4000K

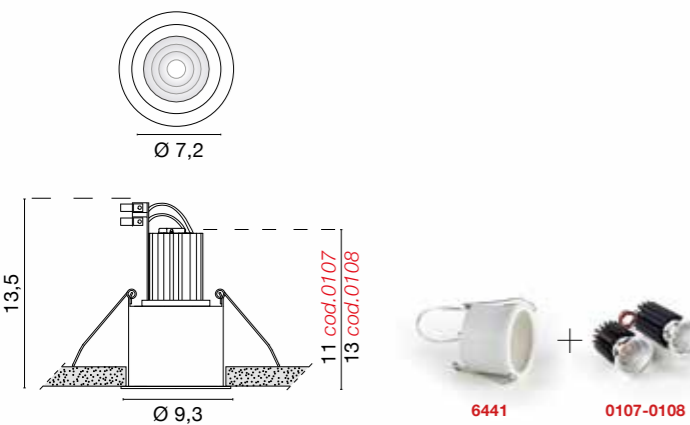

Source LED	Drivers	0125	0126	0147/COB	0128	0129	0129/DALI	0145	0145/DALI	0115/EM
		350mA	700mA	500mA	350mA	DIM	DIM DALI	DIM	DIM DALI	EMERGENCY
0107	1	NO	NO	NO	1-2	1-2	1-2	1-3	1-3	1
0108	NO	NO	1-2	NO	1-2	1-2	1-2	1-3	1-3	1
0121	1-2	1-2	NO	1-3	1-3	1-3	1-4	1-6	1-6	NO
0123	1-2	1-2	NO	1-3	1-3	1-3	1-4	1-6	1-6	NO

Accessories



0289.01
Schermo in metacrilato satinato
Satin methacrylate screen



6440 12V 0,2 kg

12V 50W GU5,3



.01 Ø 8,6 cm.

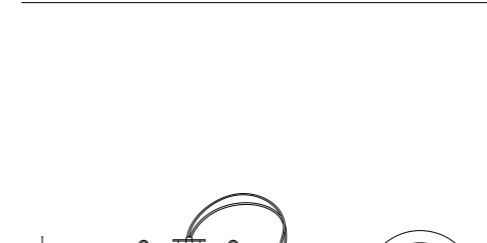

Source LED	Drivers	0125	0126	0147/COB	0128	0129	0129/DALI	0145	0145/DALI	0115/EM
		350mA	700mA	500mA	350mA	DIM	DIM DALI	DIM	DIM DALI	EMERGENCY
0107	1	NO	NO	NO	1-2	1-2	1-2	1-3	1-3	1
0108	NO	NO	1-2	NO	1-2	1-2	1-2	1-3	1-3	1
0121	1-2	1-2	NO	1-3	1-3	1-3	1-4	1-6	1-6	NO
0123	1-2	1-2	NO	1-3	1-3	1-3	1-4	1-6	1-6	NO

Accessories



0289.01
Schermo in metacrilato satinato **solo per GU10 Led**
Satin methacrylate screen **only for GU 10 Led**

6442 230V 0,2 kg

50W GU10



.01 Ø 8,6 cm.

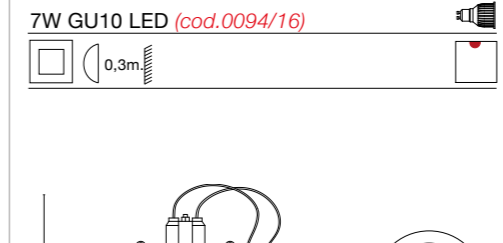

Source LED	Drivers	0125	0126	0147/COB	0128	0129	0129/DALI	0145	0145/DALI	0115/EM
		350mA	700mA	500mA	350mA	DIM	DIM DALI	DIM	DIM DALI	EMERGENCY
0107	1	NO	NO	NO	1-2	1-2	1-2	1-3	1-3	1
0108	NO	NO	1-2	NO	1-2	1-2	1-2	1-3	1-3	1
0121	1-2	1-2	NO	1-3	1-3	1-3	1-4	1-6	1-6	NO
0123	1-2	1-2	NO	1-3	1-3	1-3	1-4	1-6	1-6	NO

Accessories



0289.01
Schermo in metacrilato satinato **solo per GU10 Led**
Satin methacrylate screen **only for GU 10 Led**

DISSY TONDO

design: U.T. EGOLUCE

Spots



Faretto da incasso in alluminio con cornice in diverse finiture. Led COB con lente trasparente (/TR) o satinata (/ST).

A richiesta sono fornibili anche altre tonalità di luce 2700K o 4000K o fasci di apertura (24°-58°).

Aluminium spot with frame in different finishing. Led COB with transparent (/TR) or satin (/ST) lens.

Other light tones 2700K or 4000K and beam angles (24° - 58°) can be supplied on request.

Spot à encastrer en aluminium avec cadre en plusieurs finitions. Led COB avec lentille transparente (/TR) ou satinée (/ST).

D'autres tonalités de lumière 2700 ou 4000K et faisceaux (24°-58°) sont disponibles à la demande.

Einbaustrahler aus Aluminium, mit vielen verschiedenen Rahmenausfertigungen, COB Led mit klarglass (/TR) oder satiniert (/ST).

Auf Anfrage sind andere Lichttonen 2700 oder 4000K oder Abstrahlwinkel (24°-58°) verwendbar.

Foco empotrable en aluminio con marco en acabados variados. Led COB con lentilla transparente (/TR) o satinada (/ST).

A pedido se realizan aparatos con otras temperaturas de luz, 2700y 4000K, y hazes de luz (24°-58°).

Встроенный спот из металла в разных отделках. Светодиод COB (COB = Chip On Board = светодиоды на плате) с прозрачной (/TR) или матовой (/ST) линзой.

Светильники с другой цветовой температурой 2700К или 4000К и двумя лучами (24-58 градусов) могут быть изготовлены по запросу.

6410 0,3 kg

9,2W 18,4V 500mA 1056lm CRI>80 3000K

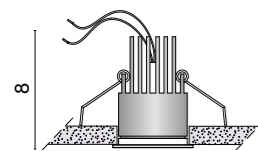

.01 .02 .03 .21 .31 .32 5 cm.

Options

/ST Con vetro satinato - Satin glass
/TR Con vetro trasparente - Clear glass

Drivers



0125 350 mA (1 Dissy) **0128** 350 mA (1-2 Dissy) **0129** Dimmer **0145** Dimmer Maxi **0147/COB** **0115/EM** Emergency Unit
0129/DALI Dimmer **0145/DALI** Dimmer M. (1-2 Dissy)





Faretti da incasso minitrim con sorgente arretrata, corpo in pressofusione d'alluminio realizzati in 4 misure diverse per consentire l'utilizzo con varie sorgenti luminose.

Minitrim spots with recessed light source, body in die cast aluminum, 4 different sizes available to fit for a wide range of light sources.

Spots minitrim à encastrer avec source reculée, corps en aluminium injecté disponibles en 4 tailles pour utilisation avec plusieurs sources lumineuses.

Minitrim Einbaustrahler mit zurückgestellten Lichtquellen, Körper Aluminium Pressguss. Die 4 verfügbaren Durchmessern ermöglichen die Benutzung von verschiedene Lichtquellen.

Focos empotrables minitrim con fuente de luz puesta arriba, cuerpo en presofusion de aluminio. Los 4 tamaños disponibles permiten el uso de diferentes fuentes de luz.

Встроенные споты с углубленным источником света, корпус из литого под давлением алюминия, белый цвет, в 4-х размерах под разные источники света.

TAPPO MINI

design: U.T. EGOLUCE

Spots

Spots

6327 tappo mini 12V 0,1kg

12V 20W GU4

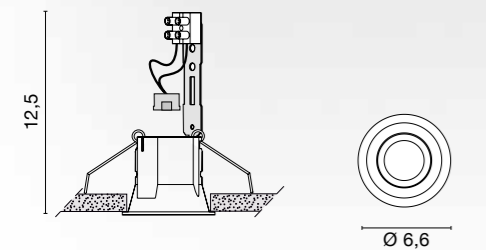

.01 5,9 cm.

TAPPO MINI LED

design: U.T. EGOLUCE

Spots

Spots

6327 tappo mini + Power led 0,15 kg



.01 5,9 cm.

Source LED cod.	OPTIC degree		lm	LED color
0120	25°	2W 500mA	209lm	4000K
0122	25°	2W 500mA	199lm	3000K

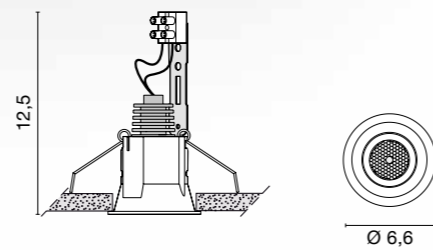

0125 350 mA (1-6 Tappo Mini) **0127** 500 mA (1-6 Tappo Mini) **0128** 350 mA (1-10 Tappo Mini) **0129** Dimmer (1-6 Tappo Mini) **0145** Dimmer Maxi (1-10 Tappo Mini) **0129/DALI** Dimmer **0145/DALI** Dimmer M.



TAPPO COB LED - MODULO POWER LED

design: U.T. EGOLUCE

Spots

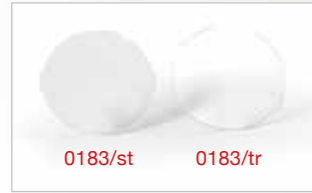

Dischetto reggi lampadina pag 449
Bulb stopper pg 449

6330 + COB LED 0,30 kg



.01 .02 .21 .25 .31 .32 .38 7,9 cm.

Source LED cod.	OPTIC degree		lm	LED color
0107/XW	124 140 160	6,2W 17,8V 350mA	740lm	2700K
0107/WW	124 140 160	6,2W 17,8V 350mA	785lm	3000K
0107/W	124 140 160	6,2W 17,8V 350mA	829lm	4000K
0107/CW	124 140 160	6,2W 17,8V 350mA	850lm	5000K
0108/XW	124 140 160	9,2W 18,4V 500mA	995lm	2700K
0108/WW	124 140 160	9,2W 18,4V 500mA	1056lm	3000K
0108/W	124 140 160	9,2W 18,4V 500mA	1115lm	4000K
0108/CW	124 140 160	9,2W 18,4V 500mA	1160lm	5000K
0108/WW/IP	38	9,2W 18,4V 500mA	1056lm	3000K
0108/W/IP	38	9,2W 18,4V 500mA	1115lm	4000K

6330 + POWER LED 0,30 kg



.01 .02 .21 .25 .31 .32 .38 7,9 cm.

Source LED cod.	OPTIC degree		lm	LED color
0121	25°	3x3W 700mA	846lm	4000K
0123	25°	3x3W 700mA	804lm	3000K

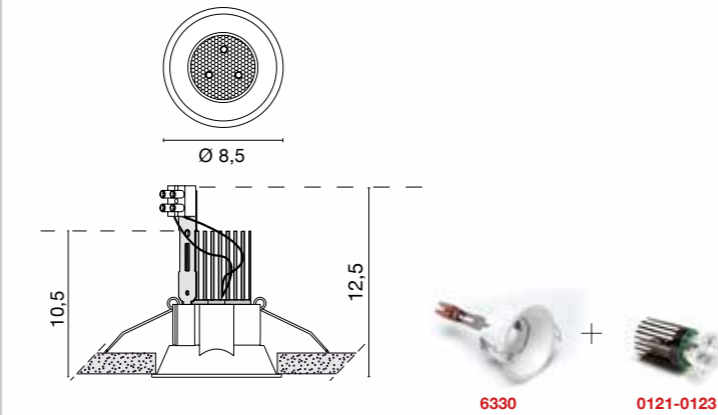
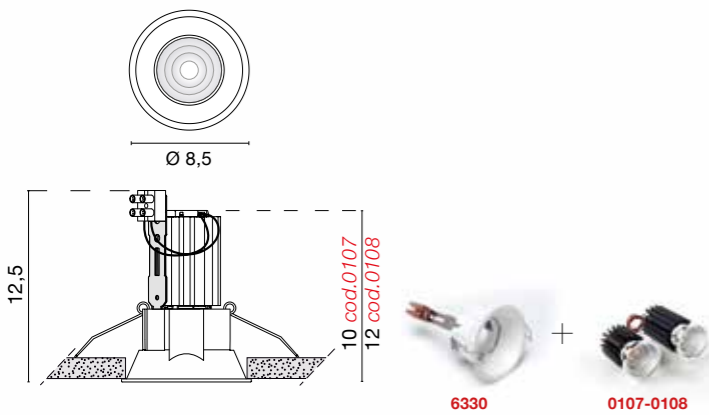

Source LED	Drivers	0126	0147/COB	0128	0129	0129/DALI	0145	0145/DALI	0115/EM
	350mA	700mA	500mA	350mA	DIM	DIM DALI	DIM	DIM DALI	EMERGENCY
0107	1	NO	NO	1-2	1-2	1-2	1-3	1-3	1
0108	NO	NO	1-2	NO	1-2	1-2	1-3	1-3	1
0121	1-2	1-2	NO	1-3	1-3	1-4	1-6	1-6	NO
0123	1-2	1-2	NO	1-3	1-3	1-4	1-6	1-6	NO

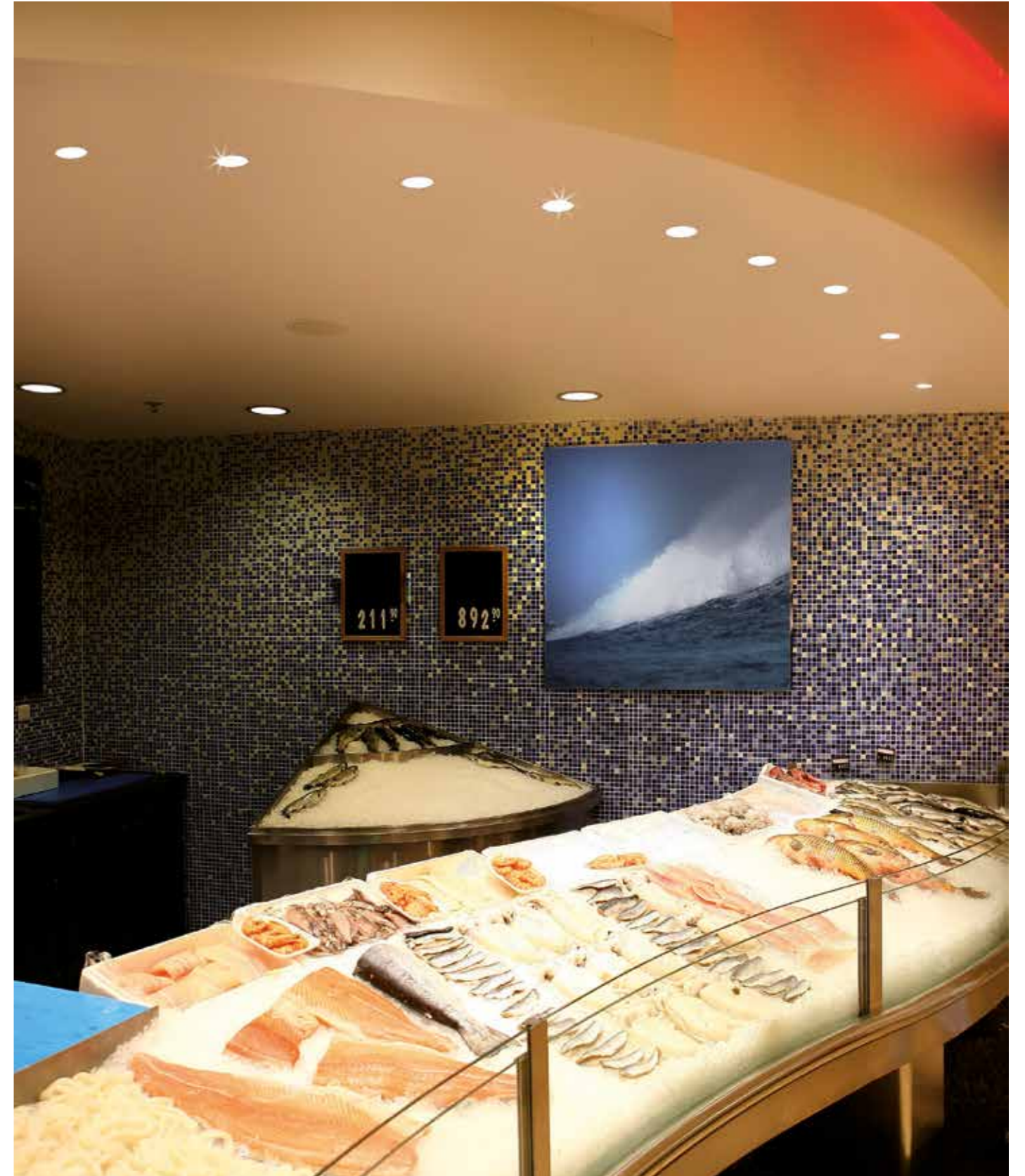

Spots

TAPPO 12V/230V

design: U.T. EGOLUCE

Spots

Spots



6330 12V 0,15kg
 12V 50W GU5,3
 III 0,3m

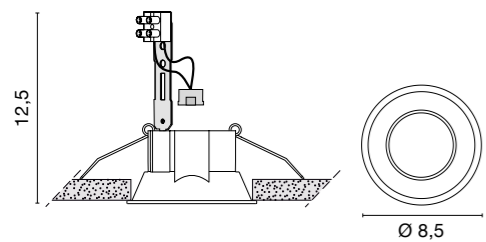

.01 .02 .21 .25 .31 .32 .38 7,9 cm.

6329 230V 0,2kg
 50W GU10
 7W GU10 LED (cod.0104/16)
 7W GU10 LED (cod.0094/16)
 F 0,3m

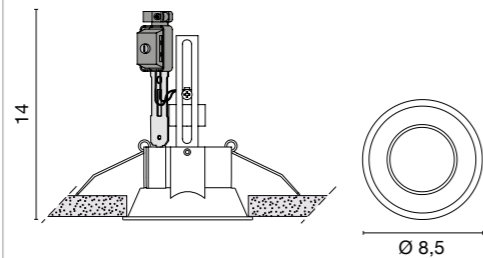

.01 .02 .21 .25 .31 .32 .38 7,9 cm.



TAPPO MAXI LED

design: U.T. EGOLUCE

TAPPO MAXI 12V

design: U.T. EGOLUCE

Spots

Spots



6399 tappo maxi LED

0,7 kg



.01

15,2 cm.

Source LED cod.		lm	LED color
/WW	24,3W 34,7V 700mA CRI>85	2730lm	3000K
/W	24,3W 34,7V 700mA CRI>85	2820lm	4000K

Options

/ST Con diffusore in metacrilato satinato - With satin methacrylate diffuser

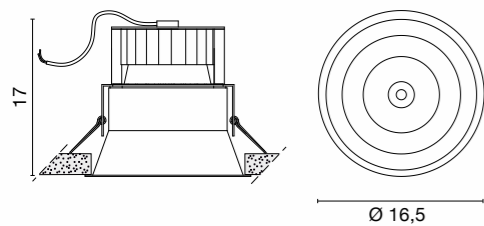

6339/ST



6339



6331 12V

0,2 kg

12V 50W G53

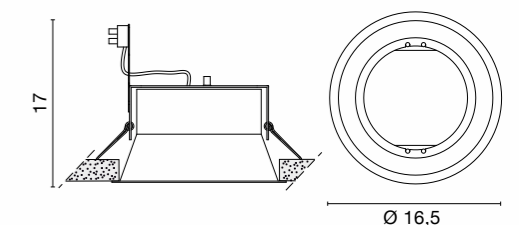

.01

15,2 cm.

Drivers

	0135	0129	0129/DALI	0145	0145/DALI	0115/EM
Driver multipower		DIM	DIM DALI	DIM	DIM DALI	EMERGENCY
6399	1	1	1	1-2	1-2	1

TAPPO ORIENTABILE COB LED - MODULO POWER LED

design: U.T. EGOLUCE

TAPPO ORIENTABILE 12V/230V

design: U.T. EGOLUCE

Spots

Spots

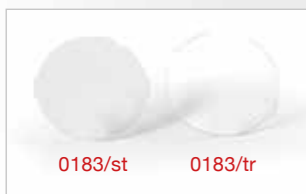

0183/st 0183/tr

Dischetto reggi lampadina pag 449
Bulb stopper pg 449

6318 Adjustable + COB led 0,35 kg

.01 .02 8,6 cm.

Source LED cod.	OPTIC degree		lm	LED color
0107/XW	124 140 160	6,2W 17,8V 350mA	740lm	2700K
0107/WW	124 140 160	6,2W 17,8V 350mA	785lm	3000K
0107/W	124 140 160	6,2W 17,8V 350mA	829lm	4000K
0107/CW	124 140 160	6,2W 17,8V 350mA	850lm	5000K
0108/XW	124 140 160	9,2W 18,4V 500mA	995lm	2700K
0108/WW	124 140 160	9,2W 18,4V 500mA	1056lm	3000K
0108/W	124 140 160	9,2W 18,4V 500mA	1115lm	4000K
0108/CW	124 140 160	9,2W 18,4V 500mA	1160lm	5000K
0108/WW/IP	38	9,2W 18,4V 500mA	1056lm	3000K
0108/W/IP	38	9,2W 18,4V 500mA	1115lm	4000K

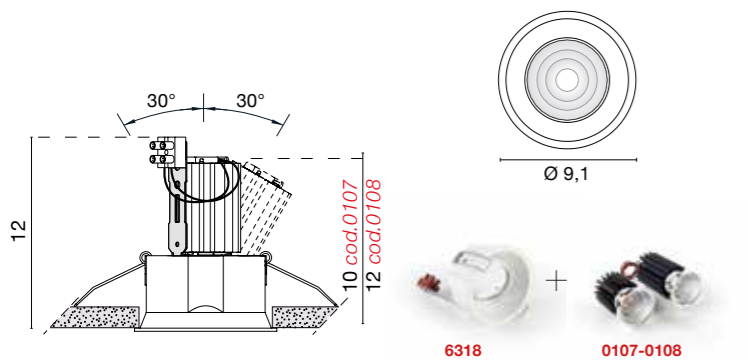

Source LED	Drivers								
	0125	0126	0147/COB	0128	0129	0129/DALI	0145	0145/DALI	0115/EM
	350mA	700mA	500mA	350mA	DIM	DIM DALI	DIM	DIM DALI	EMERGENCY
0107	1	NO	NO	1-2	1-2	1-2	1-3	1-3	1
0108	NO	NO	1-2	NO	1-2	1-2	1-3	1-3	1
0121	1-2	1-2	NO	1-3	1-3	1-4	1-6	1-6	NO
0123	1-2	1-2	NO	1-3	1-3	1-4	1-6	1-6	NO

6318 Adjustable + Power led 0,35 kg

.01 .02 8,6 cm.

Source LED cod.	OPTIC degree		lm	LED color
0121	25°	3x3W 700mA	846lm	4000K
0123	25°	3x3W 700mA	804lm	3000K

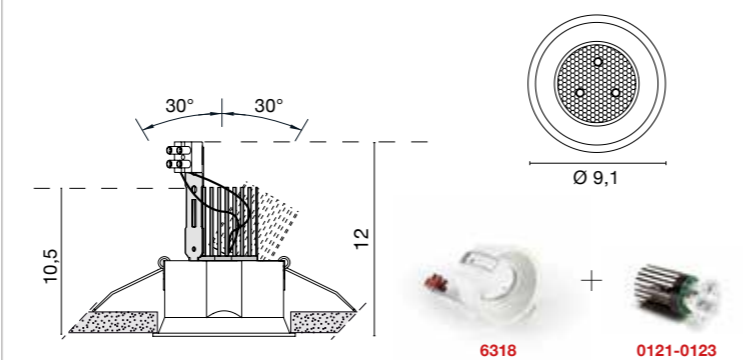

6318 12V adjustable 0,25kg

12V 50W GU 5,3

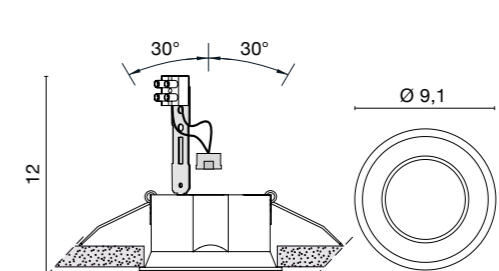

.01 .02 8,6 cm.

6319 230V adjustable 0,25kg

50W GU10
 7W GU10 LED (cod.0104/16)
 7W GU10 LED (cod.0094/16)

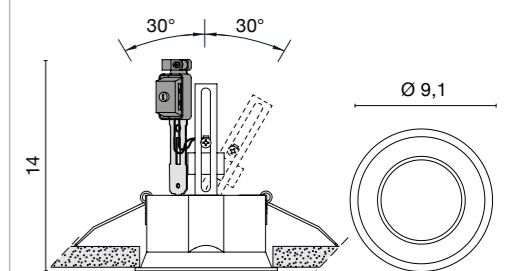

.01 .02 8,6 cm.



VERO TONDO

design: U.T. EGOLUCE

Spots

Spots



Faretti da incasso minitrim con sorgente arretrata, corpo in pressofusione d'alluminio verniciati bianchi, realizzati in 3 misure per consentire l'utilizzo di vari COB led

Minitrim spots with recessed light source, body in white coated die cast aluminum, 3 sizes available to fit a range of COB led.

Spots minitrim à encastrer avec source reculée, corps en aluminium injecté vernis blanc, disponibles en 3 tailles pour utilisation de plusieurs COB led.

Minitrim Einbaustrahler mit zurückgestellten Lichtquellen, Körper aus Weiß lackiertem Aluminium Pressguss. Die 3 verfügbaren Durchmesser ermöglichen die Benutzung von verschiedenen Lichtquellen.

Focos empotrables minitrim con fuente de luz puesta arriba, cuerpo en presofusion de aluminio pintado blanco. Los 3 tamaños disponibles permiten el uso de diferentes COB led.

Встроенный спот с тонкой рамкой, корпус из литого под давлением алюминия, окрашенного в белый цвет, в 3-х размерах, с углубленными разными источниками света.

VERO TONDO

design: U.T. EGOLUCE

Spots

Spots



6433 vero mini tondo 0,25 kg

/ww 13,8W 27,6V 500mA 1649lm CRI>80 3000K \triangle_{58}
/w 13,8W 27,6V 500mA 1741lm CRI>80 4000K \triangle_{58}

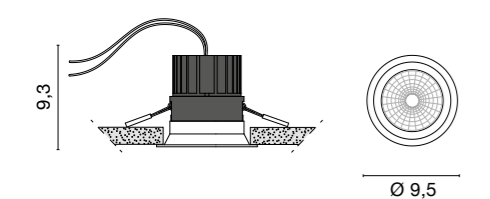

.01/W .01/WW 8,5 cm.

6434 vero tondo 0,5 kg

/ww 16,2W 32,3V 500mA 2120lm CRI>80 3000K \triangle_{50}
/w 16,2W 32,3V 500mA 2200lm CRI>80 4000K \triangle_{50}

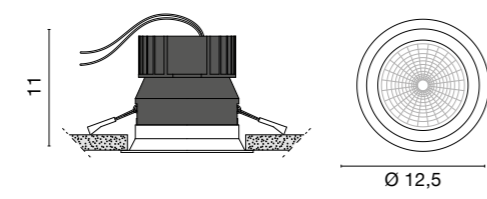
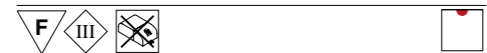

.01/W .01/WW 11,5 cm.

6435 vero maxi tondo 0,8 kg

/ww 23,4W 33,4V 700mA 2813lm CRI>80 3000K \triangle_{45}
/w 23,4W 33,4V 700mA 2919lm CRI>80 4000K \triangle_{45}

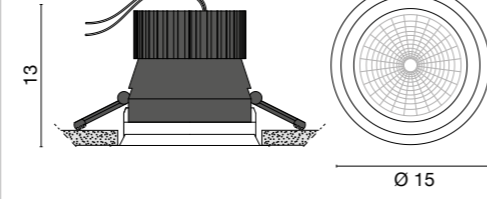

.01/W .01/WW 14 cm.

Options

/ST Con diffusore in metacrilato satinato - With satin methacrylate diffuser

/P Protezione IP44 della parte esposta - Exposed part protection IP44

	Drivers							
	0169	0147/COB	0148/COB	0129	0129/DALI	0145	0145/DALI	0115/EM
	Driver multipower	500mA	500mA	DIM	DIM DALI	DIM	DIM DALI	EMERGENCY
6433	1	1	NO	1	1	1-2	1-2	1
6434	1	1	NO	1	1	1-2	1-2	1
6435	1	NO	1	1	1	1-2	1-2	1



VERO TONDO ORIENTABILE

design: U.T. EGOLUCE

Spots

Spots



6436 0,85 kg



.01 14 cm.

Source LED cod.	OPTIC degree		lm	LED color
/WW	/30 /55	23,4W 33,4V 700mA CRI>80	2813lm	3000K
/W	/30 /55	23,4W 33,4V 700mA CRI>80	2919lm	4000K

Options
/ST Con diffusore in metacrilato satinato - With satin methacrylate diffuser

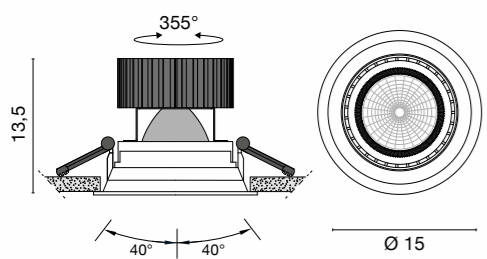

Drivers						
0169	0148/COB	0129	0129/DALI	0145	0145/DALI	0115/EM
Driver multipower	700mA	DIM	DIM	DIM	DALI	EMERGENCY
6436	1	1	1	1-2	1-2	1

VENTITRE'

design: U.T. EGOLUCE

Spots

Spots



6437 0,70 kg



.01 20 cm.

Source LED cod.	OPTIC degree	lm	LED color
/WW	94° 23,4W 33,4V 700mA CRI-80	2813lm	3000K
/W	94° 23,4W 33,4V 700mA CRI-80	2919lm	4000K

Options

/ST	Con diffusore in metacrilato satinato - With satin methacrylate diffuser
/IP	Protezione IP44 della parte esposta - Exposed part protection IP44

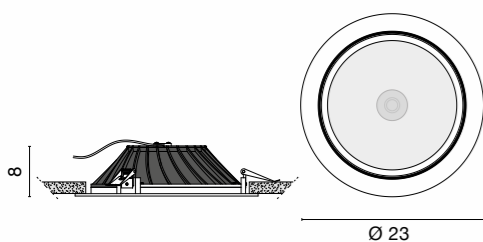

Drivers		0169	0148/COB	0129	0129/DALI	0145	0145/DALI	0115/EM
		Driver multipower	700mA	DIM	DIM	DIM	DALI	EMERGENCY
6437	1	1	1	1	1	1-2	1-2	1



6447 COB LED - MODULO POWER LED

design: U.T. EGOLUCE

6447

design: U.T. EGOLUCE

Spots

Spots

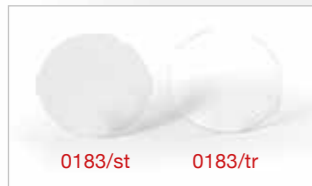
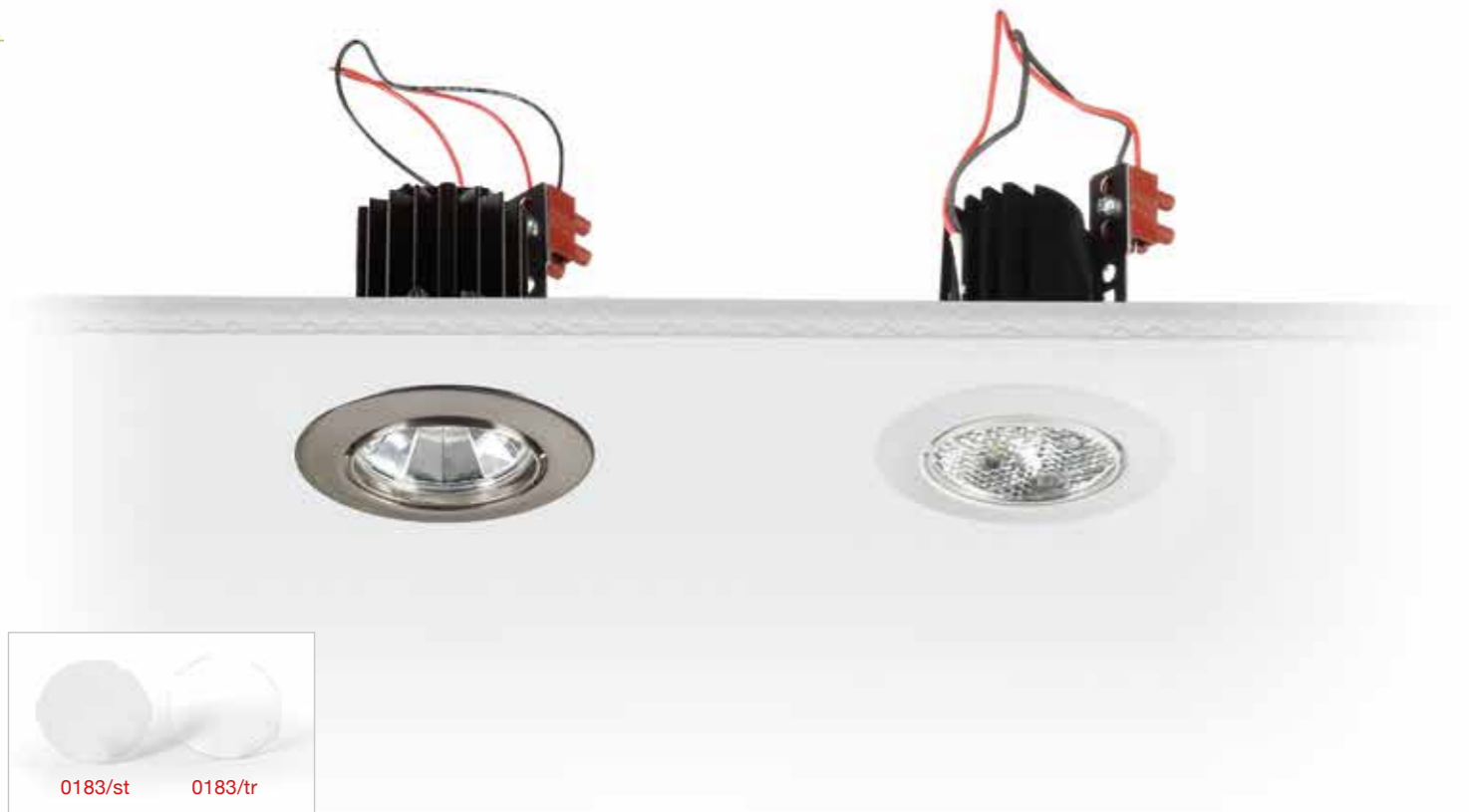

Dischetto reggi lampadina pag 449
Bulb stopper pag 449

6447 + COB led 0,13 kg

F III

.01 .02 .03 .21 .31 .32

7,5 cm.

Source LED cod.	OPTIC degree	lm	LED color
0107/XW	124 140 160	6,2W 17,8V 350mA 740lm	2700K
0107/WW	124 140 160	6,2W 17,8V 350mA 785lm	3000K
0107/W	124 140 160	6,2W 17,8V 350mA 829lm	4000K
0107/CW	124 140 160	6,2W 17,8V 350mA 850lm	5000K
0108/XW	124 140 160	9,2W 18,4V 500mA 995lm	2700K
0108/WW	124 140 160	9,2W 18,4V 500mA 1056lm	3000K
0108/W	124 140 160	9,2W 18,4V 500mA 1115lm	4000K
0108/CW	124 140 160	9,2W 18,4V 500mA 1160lm	5000K
0108/WW/IP	38	9,2W 18,4V 500mA 1056lm	3000K
0108/W/IP	38	9,2W 18,4V 500mA 1115lm	4000K

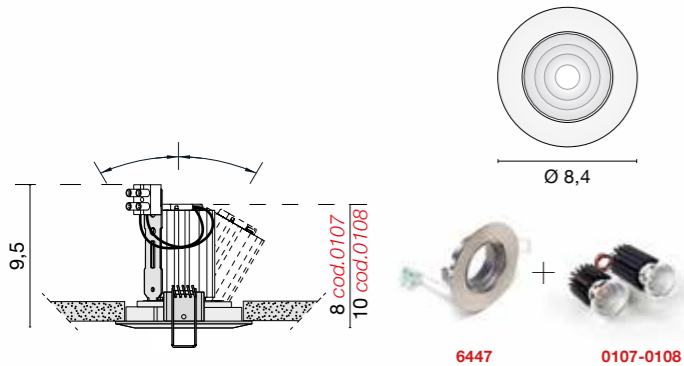

Source LED	Drivers	0125	0126	0147/COB	0128	0129	0129/DALI	0145	0145/DALI	0115/EM
		350mA	700mA	500mA	350mA	DIM	DIM DALI	DIM	DIM DALI	EMERGENCY
0107	1	NO	NO	NO	1-2	1-2	1-2	1-3	1-3	1
0108	NO	NO	1-2	NO	1-2	1-2	1-2	1-3	1-3	1
0121	1-2	1-2	NO	1-3	1-3	1-3	1-4	1-6	1-6	NO
0123	1-2	1-2	NO	1-3	1-3	1-3	1-4	1-6	1-6	NO

6447 + Power led 0,13 kg

F III

.01 .02 .03 .21 .31 .32

7,5 cm.

Source LED cod.	OPTIC degree	lm	LED color
0121	25°	3x3W 700mA 846lm	4000K
0123	25°	3x3W 700mA 804lm	3000K

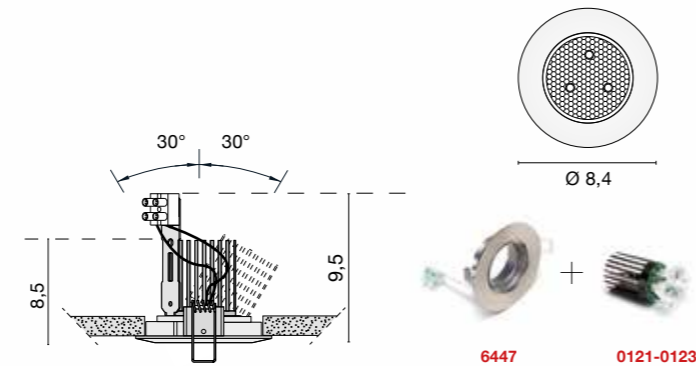

6447 12V 0,13kg

12V 50W GU5,3

F III

.01 .02 .03 .21 .31 .32

7,5 cm.

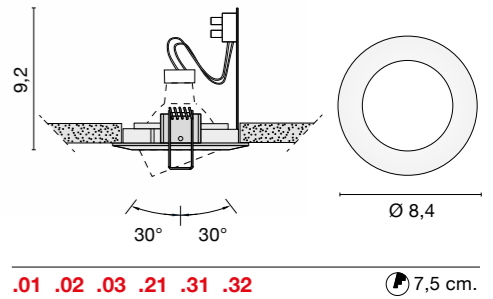

6455

design: U.T. EGOLUCE

Spots



6455 230V 0,4kg

50W GU10

7W GU10 LED (cod.0104/16)

7W GU10 LED (cod.0094/16)

F III

0,3 m

.01 .02 .03 .21 .31 .32

7,5 cm.

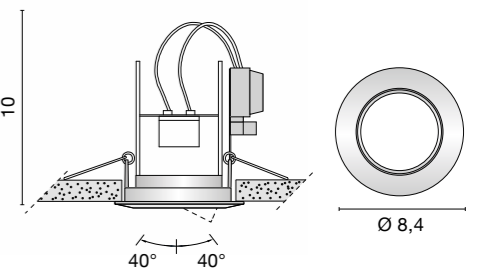

GEKO COB LED - MODULO POWER LED

design: U.T. EGOLUCE

GEKO 12V

design: U.T. EGOLUCE

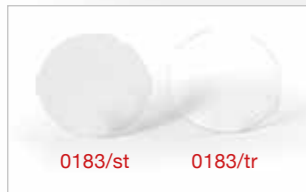
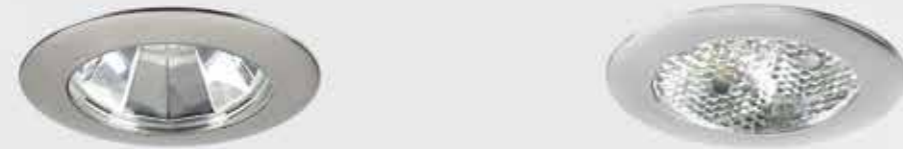

Dischetto reggi lampadina pag 449
Bulb stopper pg 449

6460 + COB led 0,13 kg

.01 .02 .21 .31 .32 6,6 cm.

Source LED cod.	OPTIC degree	lm	LED color
0107/XW	124 140 160	6,2W 17,8V 350mA 740lm	2700K
0107/WW	124 140 160	6,2W 17,8V 350mA 785lm	3000K
0107/W	124 140 160	6,2W 17,8V 350mA 829lm	4000K
0107/CW	124 140 160	6,2W 17,8V 350mA 850lm	5000K
0108/XW	124 140 160	9,2W 18,4V 500mA 995lm	2700K
0108/WW	124 140 160	9,2W 18,4V 500mA 1056lm	3000K
0108/W	124 140 160	9,2W 18,4V 500mA 1115lm	4000K
0108/CW	124 140 160	9,2W 18,4V 500mA 1160lm	5000K
0108/WW/IP	38	9,2W 18,4V 500mA 1056lm	3000K
0108/W/IP	38	9,2W 18,4V 500mA 1115lm	4000K

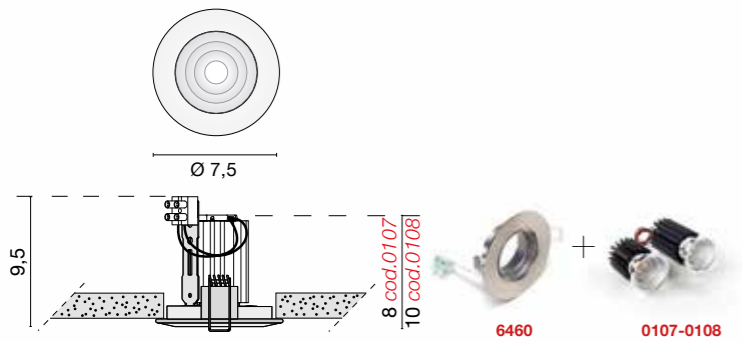

Source LED	Drivers								
	0125 350mA	0126 700mA	0147/COB 500mA	0128 350mA	0129 DIM	0129/DALI DIM DALI	0145 DIM	0145/DALI DIM DALI	0115/EM EMERGENCY
0107	1	NO	NO	1-2	1-2	1-2	1-3	1-3	1
0108	NO	NO	1-2	NO	1-2	1-2	1-3	1-3	1
0121	1-2	1-2	NO	1-3	1-3	1-4	1-6	1-6	NO
0123	1-2	1-2	NO	1-3	1-3	1-4	1-6	1-6	NO

6460 + Power led 0,13 kg

.01 .02 .21 .31 .32 6,6 cm.

Source LED cod.	OPTIC degree	lm	LED color
0121	25°	3x3W 700mA 846lm	4000K
0123	25°	3x3W 700mA 804lm	3000K

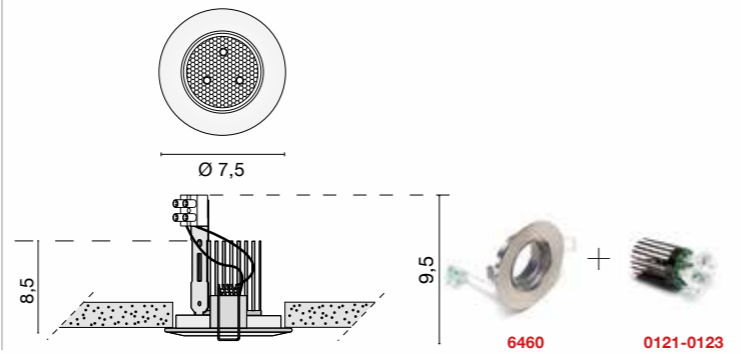

6460 0,08kg

12V 50W GU5,3

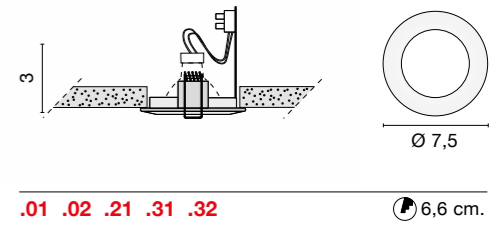

GEKO 230V

design: U.T. EGOLUCE



6290 0,25kg

50W GU10

7W GU10 LED (cod.0104/16)

7W GU10 LED (cod.0094/16)

0,3 m

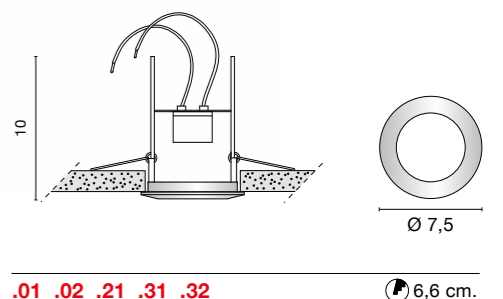

ZIC

Spots



6137 0,3 kg

12V 20W G4

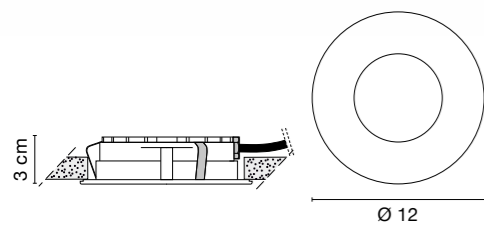
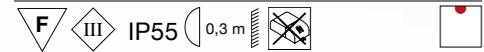

.01 11 cm.

PINCO COB

Spots



6352 0,5 kg

18V 250mA 4,5W 600lm 3000K

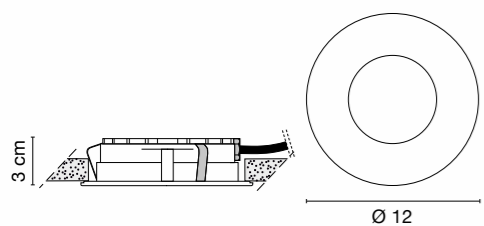

.01 11 cm.

Drivers



0125/250 250 mA
(1-2 Pinco COB)



Spots

OKKIO

Spots



6139 0,1 kg

12V 20W G4 

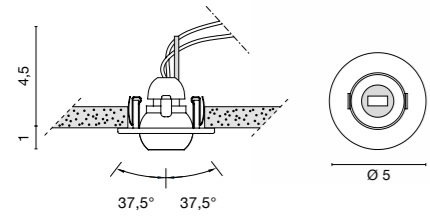

.01 .21 .31 .32  4,5 cm.

OKKIO LED

Spots



6324 0,1 kg

/ww 1W 350mA 143lm 3000K 

/w 1W 350mA 151lm 4000K 

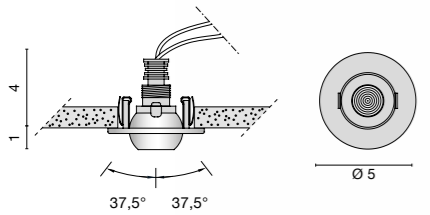

.01/W .01/WW .32/W .32/WW  4,5 cm.

Drivers



0125 350 mA (1-6 Okkio led) **0128** 350 mA (1-10 Okkio led) **0129** Dimmer **0145** Dimmer Maxi
0129/DALI Dimmer **0145/DALI** Dimmer M.



Spots

ZEN

Spots

6251 0,07 kg

12V 20W G4 



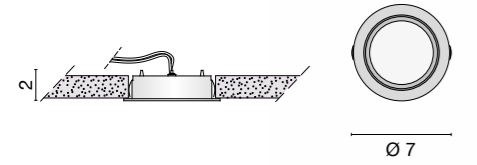

.01 .21 .31 .32 



ZEN LED

Spots

6365 0,07 kg

/WW Led max 2W 500mA 199lm 3000K 

/W Led max 2W 500mA 209lm 4000K 



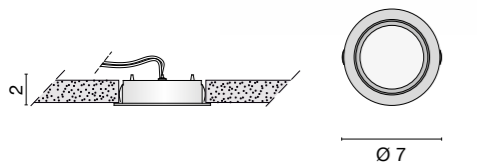

**.01/W .01/WW .21/W .21/WW
.31/W .31/WW .32/W .32/WW** 



Drivers



0125 350 mA (1-6 Zen led) **0127** 500 mA (1-6 Zen led) **0128** 350 mA (1-10 Zen led) **0129** Dimmer **0145** Dimmer Maxi **0129/DALI** Dimmer **0145/DALI** Dimmer M.

Accessories



0232 Cassaforma da parete Wall Plastic Box Only for 6365

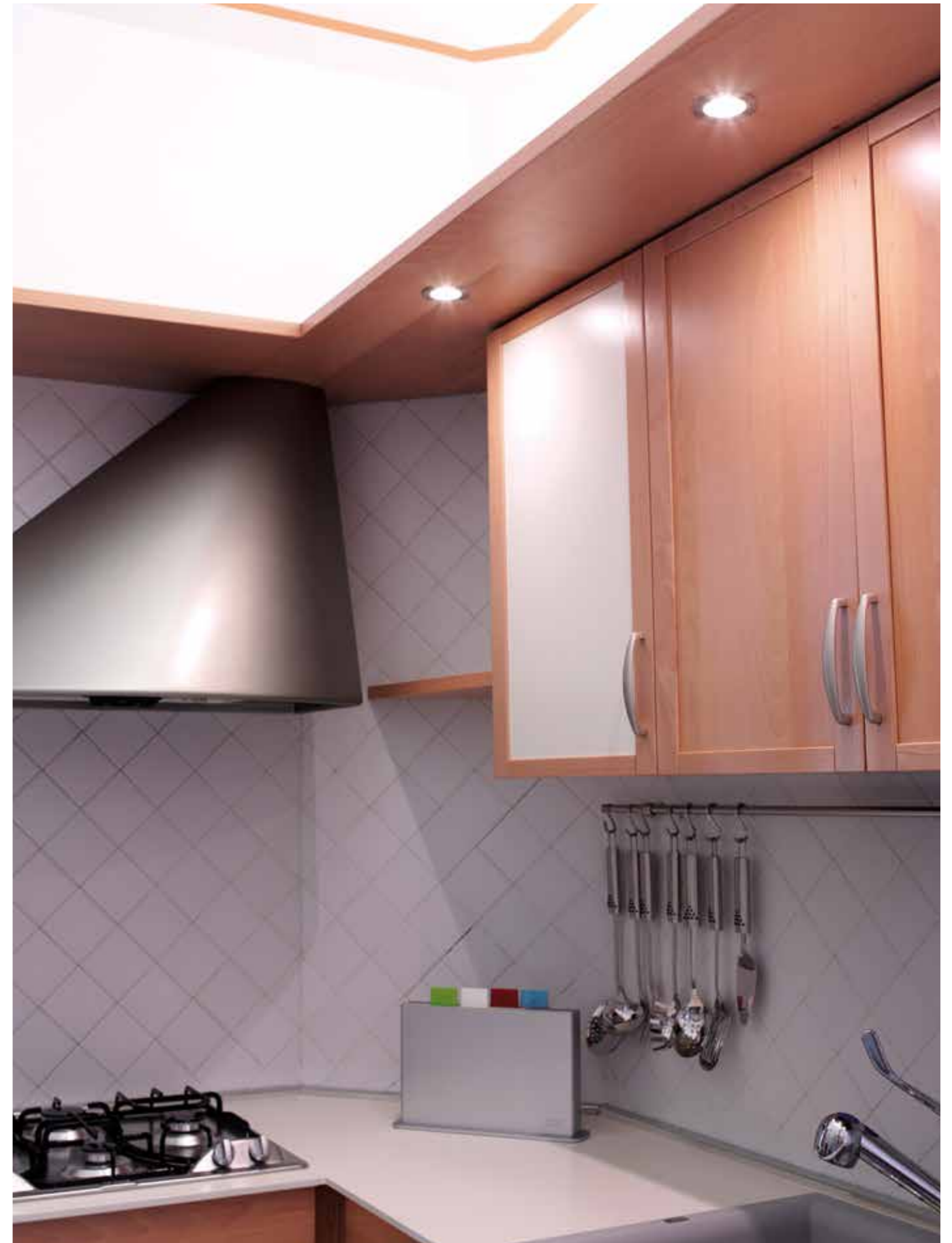

Spots

6204

6204	0,03 kg
12V 10W G4	
12V 20W G4	
	0,3 m

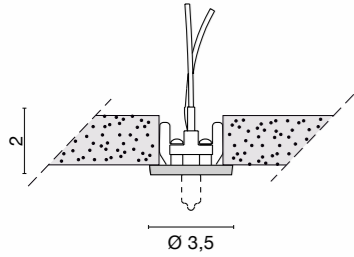

.01 .31 .32 2,6 cm.



GAMMA

design: U.T. EGOLUCE

6249	0,3 kg
50W GU10	
75W GU10	
7W GU10 LED (cod.0104/16)	
7W GU10 LED (cod.0094/16)	
	0,5 m

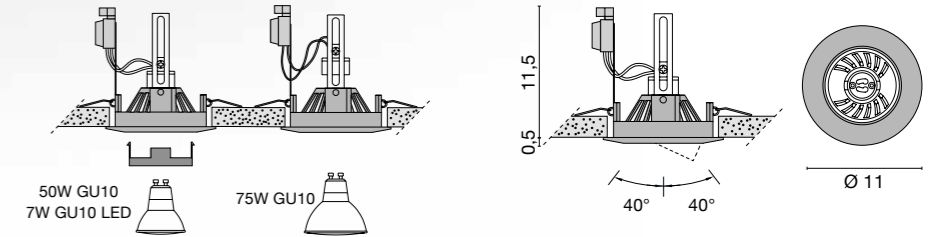

.01 .21 .31 .32 9,7 cm.

6239

6239	0,09 kg
12V 20W GU4	
	0,3 m

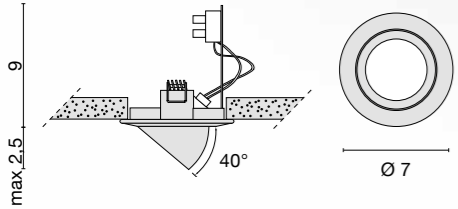

.01 .03 .21 .31 .32 6 cm.



EOS PIÙ

design: U.T. EGOLUCE

6263	0,25 kg
50W GU10	
75W GU10	
7W GU10 LED (cod.0104/16)	
7W GU10 LED (cod.0094/16)	
	0,5 m

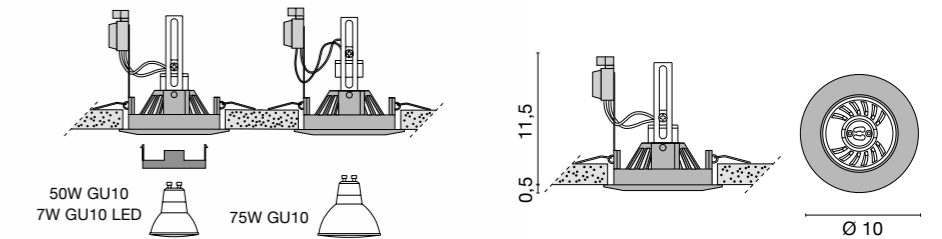

.01 .21 .31 .32 8 cm.

6240

6240	0,2 kg
12V 50W GU5,3	
	0,3 m

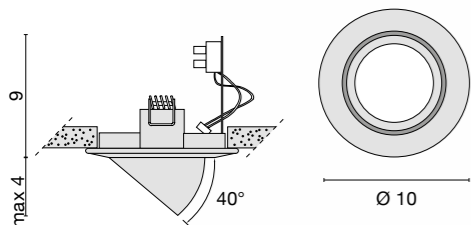

.01 .21 .31 .32 8,5 cm.



FRIDA

design: U.T. EGOLUCE

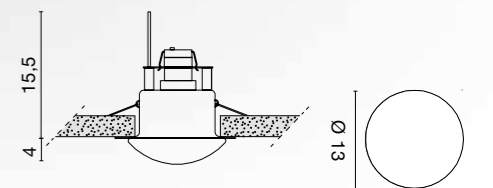

6165	0,65kg
42W E27 ECO	
12W E27 LED (cod.0105/16)	



.57 10 cm.

6024

Spots

6024	0,07 kg
28W E14 ECO	
6W E14 LED (cod.0105/MINI)	
F	

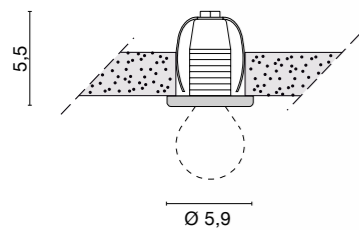



.01 .22 .32  4,5 cm.



6030

Spots

6030	0,07 kg
28W E14 ECO	
6W E14 LED (cod.0105/MINI)	
F	

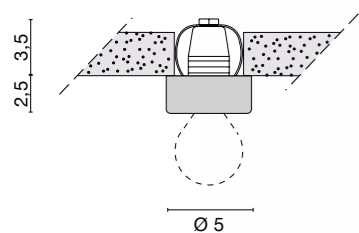



.01 .22 .32  3,5 cm.



6028

Spots

6028	0,1 kg
28W E14 ECO	
6W E14 LED (cod.0105/MINI)	
F	

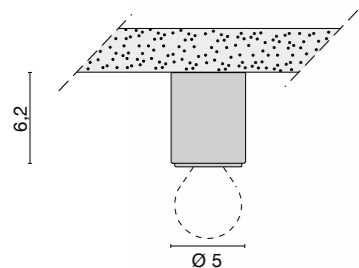

.01 .22 .32



Spots

LED Technologies

COB LED	p. 408
MULTICHIP TECHNOLOGY	p. 410
POWER LED	p. 411
FLEXIBLE CIRCUIT	p. 412
220V - 240V LED	p. 413

LED Control Systems

GENERAL INDICATION	p. 414
DIMMING 1...10V - PUSH for power led - COB led	p. 416
DIMMING DALI for power led - COB led	p. 418
DIMMABLE CONVERTER 24V 1...10V - PUSH - DALI for Strip led	p. 420
DIMMING 12V-24V 1...10V - PUSH - DALI for Strip led	p. 422
RGB CONTROL for power led - COB led	p. 424
RGB CONTROL for Strip led	p. 426
DMX INTERFACE LED EMERGENCY UNIT	p. 430

Installations

INSTALLATIONS EXAMPLES	p. 434
-------------------------------	--------

Accessories

ACCESSORIES	p. 438
DRIVERS	p. 441
BULBS	p. 446

TECHNOLOGY

COB LED-Chip On Board



I Moduli COB LED di ultima generazione con riflettore sono ideali per l'illuminazione diretta.

Le dimensioni dei LED ed il posizionamento arretrato rispetto al riflettore, rendono i moduli molto simili alla tradizionale lampadina alogena dicroica e al tempo stesso riducono l'abbagliamento diretto garantendo un cono di luce uniforme e confortevole.

L'alta efficienza (superiore ai 110 lm/watt) ed i diametri delle ottiche, uguali a quelli delle sorgenti alogene dicroiche da 50mm., consentono l'inserimento dei moduli anche nei faretti ad incasso.

Latest generation COB LED modules with reflector are perfect for direct lighting.

Reduced chips dimension and their recessed positioning above the reflector makes this modules a natural replacement for traditional dichroic but at the same time eliminates glare, granting a uniform and comfortable light beam.

High efficiency (up to 110 Lm/w) and same 50mm. diameter as standard dichroic bulbs enable the use of these modules also into recessed spots.

COB LED

- Dimmable
- CRI > 80
- Lifetime 35.000 h.
- Alimentatore elettronico separato - Separate electronic driver

Source COB LED cod.	OPTIC degree		lm	lm/W	LED color
0107/XW	124 140 160	6,2W 17,8V 350mA	740lm	119	2700K
0107/WW	124 140 160	6,2W 17,8V 350mA	785lm	126	3000K
0107/W	124 140 160	6,2W 17,8V 350mA	829lm	133	4000K
0107/CW	124 140 160	6,2W 17,8V 350mA	850lm	137	5000K
0108/XW	124 140 160	9,2W 18,4V 500mA	995lm	108	2700K
0108/WW	124 140 160	9,2W 18,4V 500mA	1056lm	114	3000K
0108/W	124 140 160	9,2W 18,4V 500mA	1115lm	121	4000K
0108/CW	124 140 160	9,2W 18,4V 500mA	1160lm	126	5000K
0108/WW/IIP	38	9,2W 18,4V 500mA	1056lm	114	3000K
0108/W/IIP	38	9,2W 18,4V 500mA	1115lm	121	4000K

Light quality

Indice resa cromatica

L'indice di resa cromatica (IRC o Ra), di una sorgente luminosa è una misura di quanto naturali appaiano i colori degli oggetti da essa illuminati.

The colour rendering index (CRI o Ra) of a light source is a measure of how natural appears the colour of enlightened objects.

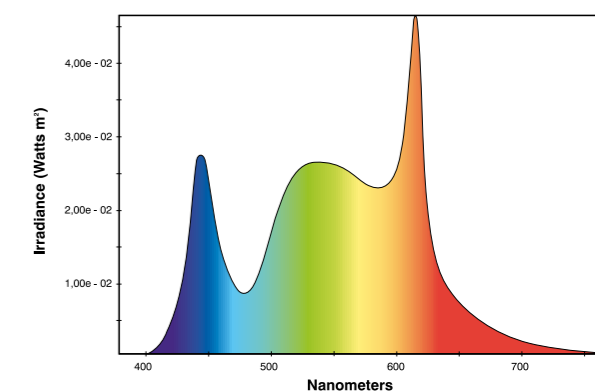



La nuovissima tecnologia delle schede multichip con LED SMD consente di avere una luce gradevole ed uniforme (stabilità di colore MacAdam 3), particolarmente indicata per soluzioni d'illuminazione architeturale. Le schede auto-dissipanti riducono il peso degli apparecchi e garantiscono una praticità d'installazione; Le dimensioni e l'altissima efficienza (superiori ai 130 lm/watt) permettono un utilizzo delle schede alternativo alle lampade fluorescenti compatte e T5 lineari risolvendo problematiche estetiche (accensione immediata e assenza di ombre), d'installazione, manutenzione e smaltimento.

The most recent technology of multichip layers with SMD LED provides comfortable and uniform lighting (MacAdam color stability ellipses 3) particularly suitable for architectural lighting solutions. The use of self-cooling plates reduces fixture weight and grants easiness of installation. Similar dimensions and its top class efficiency (over 130 lm/W) enable the use of these light sources as an alternative to fluorescent compact and T5 linear bulbs, putting an end to esthetic troubles (immediate switching, shades) as well as installation, maintenance and disposal problems.



I moduli Spot con POWER LED e lenti fisse sono ideali per illuminazione puntuale (d'accento).

I diametri delle ottiche, uguali a quelli delle sorgenti alogene dicroiche da 35mm. 50mm., consentono l'inserimento dei moduli nei faretti ad incasso.

La disponibilità di lenti fisse con varie aperture 10°, 25°, 40° e di diverse temperature di colore della luce bianca 3000K - 4000K permette la creazione di differenti scenari luminosi.

Spot modules with POWER LED and fixed lenses are ideal for narrow beam accent lighting.

Proposed diameters are the same of dichroic halogen bulbs 35mm and 50mm to allow the use of these modules in a range of recessed spots. The availability of a range of beam angles 10°, 25°, 40° and light colors 3000K or 4000K enables the creation of different light scenarios.

art. 0121/0123
POWER LED 3x3
Alimentatore elettronico separato
Separate electronic driver

Dimmable
9 W (potenza effettiva 6,7W)
804 lm
120 lm/W
CRI>80
3000/4000K
35.000 h.
Beam angle 25°

art. 0120/0122
POWER LED 1x2
Alimentatore elettronico separato
Separate electronic driver

Dimmable
2W (potenza effettiva 1,7W)
199 lm
117 lm/W
CRI>80
3000/4000K
45.000 h.
Beam angle 25°



La tecnologia dei circuiti flessibili si adatta alle nuove interpretazioni della luce e consente di creare percorsi di luce continui senza interruzioni o ombre.

La produzione Made in Italy garantisce il pieno controllo della qualità della luce con colore e resa sempre costanti e uniformi.

Tutti i prodotti EGOLUCE pensati con questa tecnologia sono realizzabili con taglio modulare. (vedi tabelle singoli prodotti).

Flexible circuits technology is supporting new light interpretations allowing the creation of endless lighting paths without shades or interruptions.

Our productions Made in Italy allows to have full control on light quality with uniform color bin and constant lumen output.

All EGOLUCE products based on this technology are available on demand in different modular lengths. basis (see different product tables).

Strip LED

- Dimmable

- CRI > 80

- Lifetime 50.000 h.

- Alimentatore elettronico separato - Separate electronic driver

Strip LED/mt.		lm	lm/W	LEDcolor	
60 LED/mt	14,4W 24V	1500lm	104	2700K	Beam angle each LED 120°
60 LED/mt	14,4W 24V	1600lm	111	3000K	Beam angle each LED 120°
60 LED/mt	14,4W 24V	1700lm	118	4000K	Beam angle each LED 120°
70 LED/mt	15W 24V	1780lm	118	2700K	Beam angle each LED 120°
70 LED/mt	15W 24V	1900lm	126	3000K	Beam angle each LED 120°
70 LED/mt	15W 24V	2000lm	133	4000K	Beam angle each LED 120°
84 LED/mt	18W 24V	2150lm	119	2700K	Beam angle each LED 120°
84 LED/mt	18W 24V	2380lm	132	3000K	Beam angle each LED 120°
84 LED/mt	18W 24V	2400lm	133	4000K	Beam angle each LED 120°
120 LED/mt	9,6W 24V	960lm	100	2700K	Beam angle each LED 120°
120 LED/mt	9,6W 24V	1020lm	106	3000K	Beam angle each LED 120°
120 LED/mt	9,6W 24V	1080lm	112	4000K	Beam angle each LED 120°

La tecnologia LED 220/240V, oltre a garantire tutti i vantaggi tipici della luce led come l'elevatissima efficienza ed una lunga durata di vita, aggiunge altre specifiche prerogative quali le dimensioni minime ed il peso ridotto.

Il modulo, progettato in doppio isolamento, è alimentato direttamente a tensione di rete 220/240V e ciò permette di ridurre l'ingombro all'interno degli apparecchi eliminando totalmente le problematiche relative all'alloggiamento di un converter.

Tali caratteristiche rendono questa tecnologia LED particolarmente adatta per l'utilizzo in lampade da parete e plafoniere, specialmente se di dimensioni ridotte.

I moduli sono dotati di protezioni fino ad 1Kv.

Per assicurare la protezione contro sovratensioni superiori (transitorie ed impulsive) che possono essere causate sia da eventi atmosferici (fulmini), che da manovre di apertura o commutazione di circuiti, guasti, etc., si raccomanda l'utilizzo di art. 0272/SPD.

Questi SPD (Surge Protective Device) sono da installare sulla linea a monte degli apparecchi.

220/240V LED technology does not only grant all typical advantages of LED lighting such as very high efficiency and long operational lifetime but it also adds some additional features as smaller dimensions and reduced weight.

The module, designed to grant double insulation, works directly at supply tension 220/240V. This allows to save space inside the lamp body and solves all issues generated by the need of a converter.

All these features makes this LED technology fit for wall/ceiling fixtures especially when they are of small dimensions.

Modules are protected from overvoltages up to 1Kv.

To grant protection from higher overvoltages (impulsive or transient) that can be caused by atmospheric events (lightning), but also by circuit opening or closing operated by switches, fault conditions, etc., we recommend the use of item 0272/SPD.

The SPD (Surge Protective Device) must be installed on the main voltage supply line before the light fixtures.



Art. 0272/SPD

INDICAZIONI GENERALI

GENERAL INFORMATION

I nostri LED di potenza devono essere alimentati a bassa tensione SOLO con corrente continua e collegati IN SERIE. I nostri alimentatori sono predisposti per questo collegamento.

Our power LED must be powered ONLY with low voltage direct current ONLY IN SERIAL CONNECTION. Our converters are predisposed for this kind of connection.

Nos LED haute puissance doivent être alimentés SEULEMENT en courant direct en basse tension et installés EN SERIE. Nos alimentateurs sont prévus pour cette liaison.

Unser power LED sollen NUR mit niedervoltige D.C. Konverter als SERIENVERBINDUNG. Unsere Konverters sind für diese Verbindungsart vorgesehen.

Nuestros LED de potencia se deben alimentar con baja tensión SOLO con corriente continua y conectados EN SERIE. Nuestros alimentadores están preparados para esta conexión.

Наши светодиоды высокой мощности должны запитываться только постоянным током низкого напряжения только при ПОСЛЕДОВАТЕЛЬНОМ ПОДКЛЮЧЕНИИ. Наши конвертеры предназначены для такого подключения.

Si consiglia di non superare i 20 mt. nella lunghezza dei cavi tra alimentatore e LED. Collegare tutti i faretto prima di alimentare il circuito.

We recommend not to exceed 20 m. of circuit length between converter and LED. Connect all elements before to give tension to the circuit.

On conseille de ne pas dépasser le 20 m. de longueur entre alimentateur et LED. Brancher tous les éléments avant d'alimenter le circuit.

Die Verkabelung zwischen Konverter und LED soll nicht länger als 20 m. sein. Alle di Elemente anschließen vor den Stromkreis einzuschalten.

Se aconseja no exceder en la longitud de los cables entre el alimentador y LED. Conectar todos los focos antes de alimentar el circuito.

Мы рекомендуем, чтобы между конвертером и светильником было не более 20 метров. Подсоединить все светильники прежде, чем подавать напряжение.

Rispettare le polarità nel collegamento elettrico per un corretto funzionamento.

Respect correct polarity when connecting.

Respecter la polarité dans l'installation pour un correct fonctionnement.

Beachten die richtige Polarisation bei der Installation.

Respetar la polaridad en la conexión para una buena instalación.

Соблюдать полярность подсоединений

E' vivamente sconsigliata l'installazione di interruttori tra alimentatore e led.

We strongly recommend to avoid installation of switches between converter and LED.

Ne pas installer des interrupteurs entre alimentateur et LED.

Zwischen Konverter und LED muss Kein Schalter installiert werden.

Es muy aconsejable la instalación de interruptores entre alimentador y LED.

Не монтировать выключатель между конвертером и светильником.

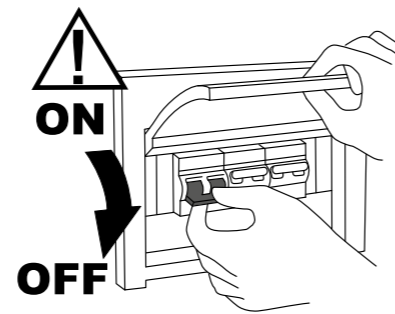

Ingresso/input
220-240V AC 50/60Hz

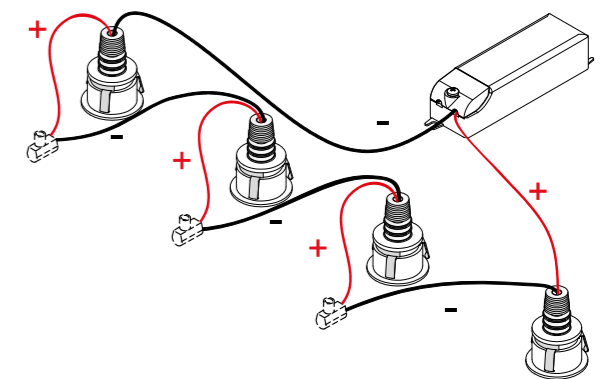
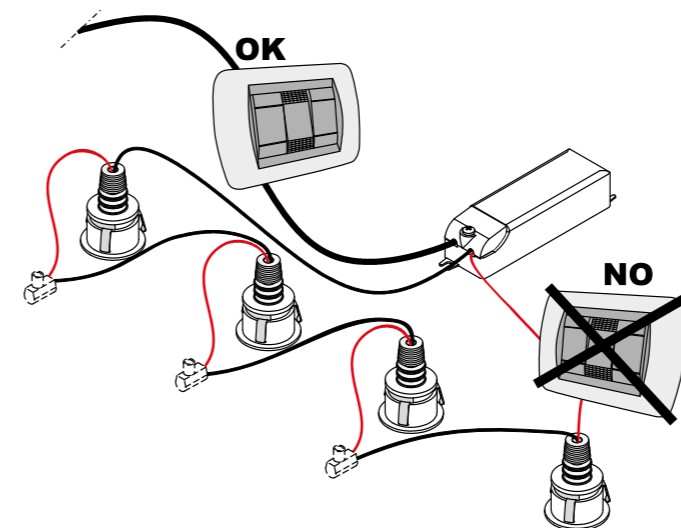
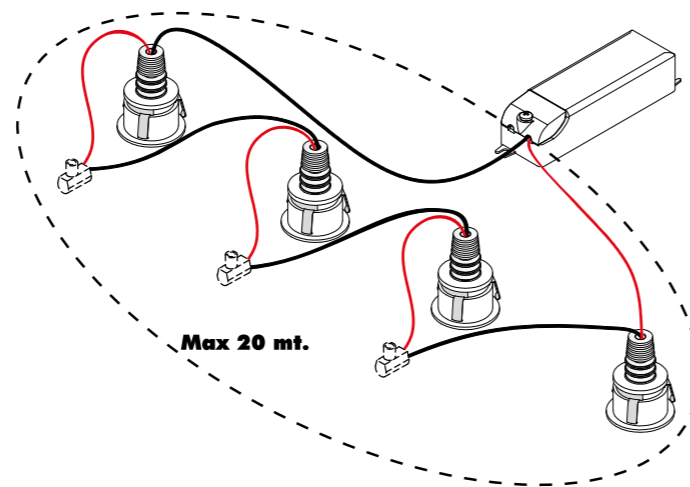
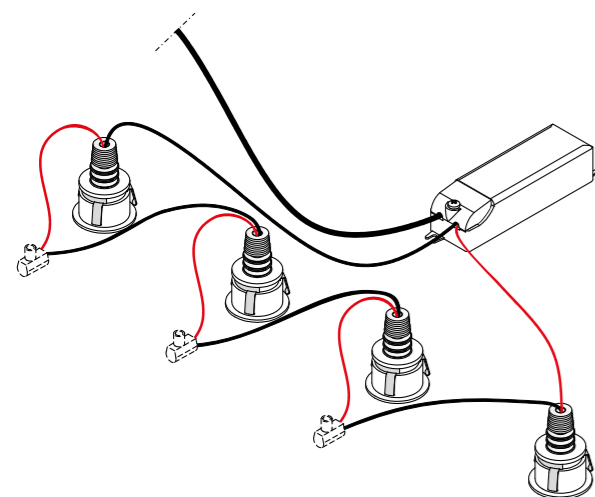

DIMMERAZIONE 1...10V & PUSH PER COB E POWER LED

1...10V & PUSH DIMMING FOR COB AND POWER LED

Alimentatori multipotenza forniti di dip-switch per la selezione della corrente in uscita. Regolazione della luminosità 0-100% mediante funzione PUSH, interfaccia 1...10V. **Art. 0133** cavetto di sincronizzazione fornito separatamente; max 10 alimentatori sincronizzati, di cui uno solo comandato. (1 Master + 9 Slaves)

Multi-power drivers supplied with dip-switch for selection of the output current. Light regulation 0-100% by means of PUSH function, 1...10V interface. **Art. 0133** synchronization cable is sold separately, one commanded master driver can synchronize up to max. 9 slaves

PUSH

Regolazione della luminosità mediante la funzione PUSH. Una breve pressione per accendere e spegnere; una pressione prolungata per aumentare o diminuire l'intensità luminosa. La regolazione si ferma automaticamente ai valori minimi e massimi. Per un nuovo comando accensione, regolazione o spegnimento, rilasciare il pulsante e dare nuovamente il comando desiderato. **Attenzione:** Usare solo pulsanti di tipo normalmente aperto privi di spia luminosa incorporata.

Light regulation by means of PUSH function. A short push to turn on and off; a longer push to increase or decrease light intensity. Regulation automatically stops at minimum and maximum values. For another on, regulation or off command, release the push button and give the desired command again. **Attention:** only use normally open push buttons with no incorporated warning light.

0129

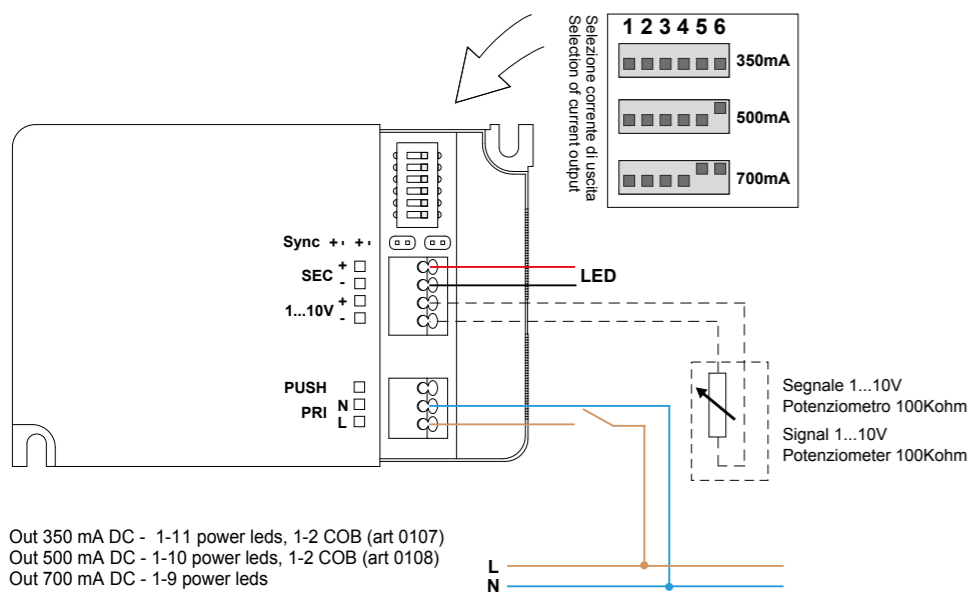

1...10 V

Per la regolazione mediante 1...10V il sistema è provvisto di morsetto specifico attivo.

For light regulation 1...10V the control systems are provided of active terminal connection.

0129

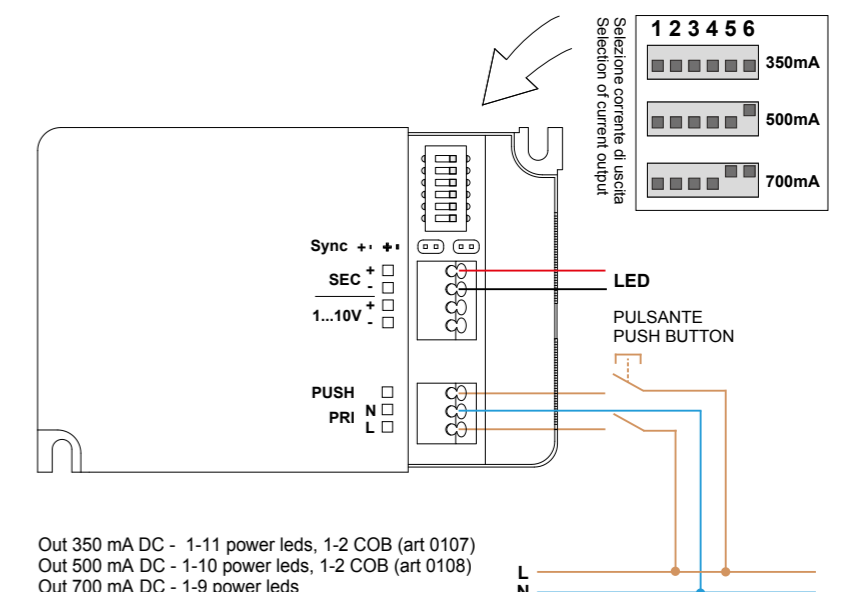

0145

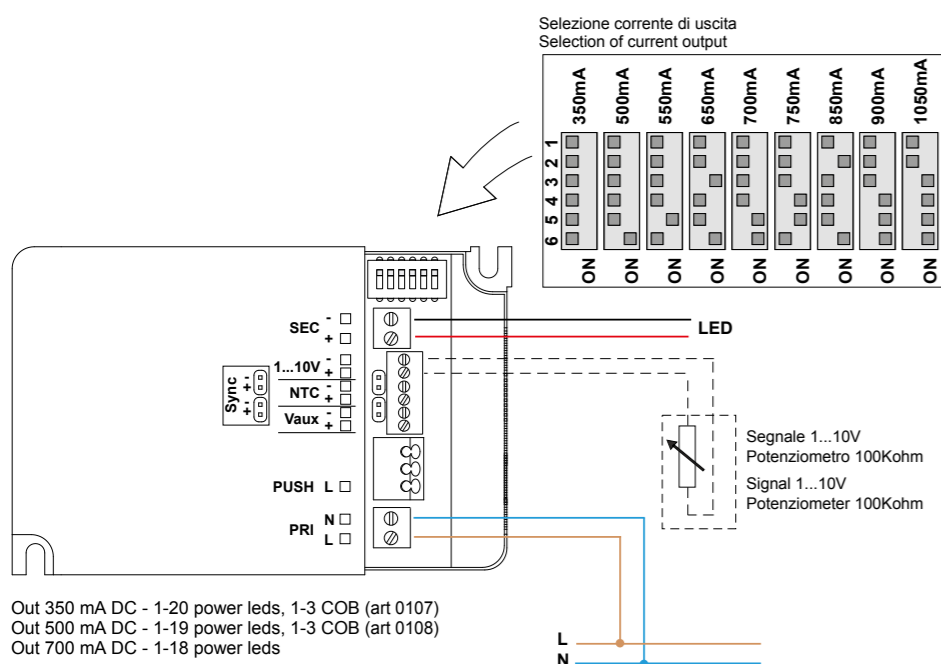

0145

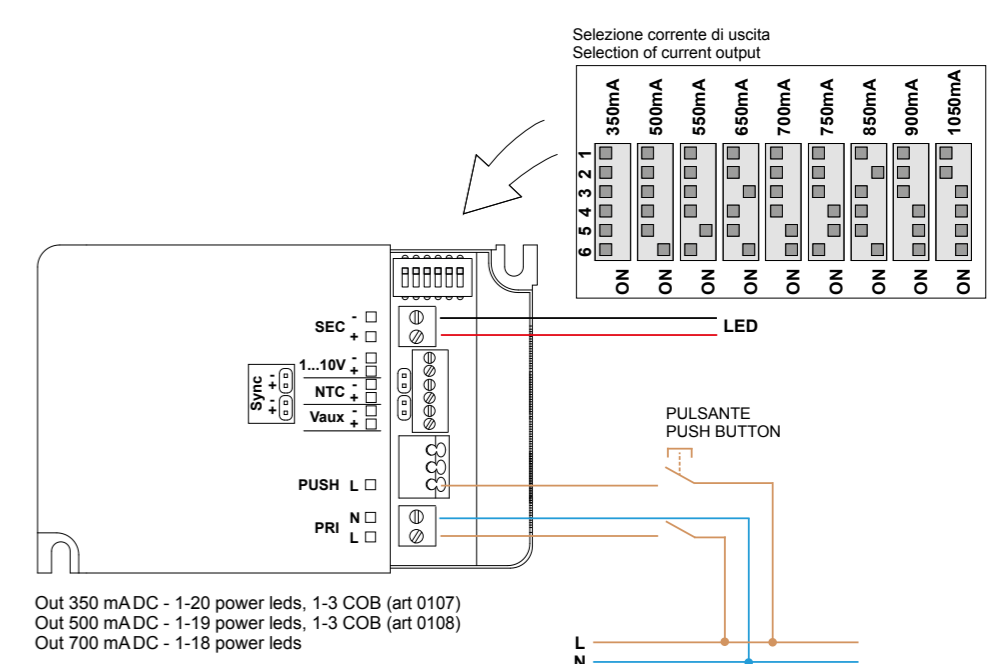

DIMMERAZIONE DALI PER COB E POWER LED

DALI DIMMING FOR COB AND POWER LED



Alimentatori multipotenza forniti di dip-switch per la selezione della corrente in uscita.
 Caratteristiche della regolazione DALI (0,5-100%):

- funzione di memoria per scenari o gruppi luminosi
- richiamo di funzioni memorizzate
- compatibilità con interfacce DALI standard

Art. 0133 cavetto di sincronizzazione fornito separatamente; max 10 alimentatori sincronizzati, di cui uno solo comandato.

Multi-power drivers supplied with dip-switch for selection of the output current.
 Features DALI dimming (0,5-100%):

- memory function for sets or light groups
- recall of stored functions
- compatible with standard DALI interfaces

Art. 0133 synchronization cable is sold separately, one commanded master driver can synchronize up to max. 9 slaves



0129/DALI

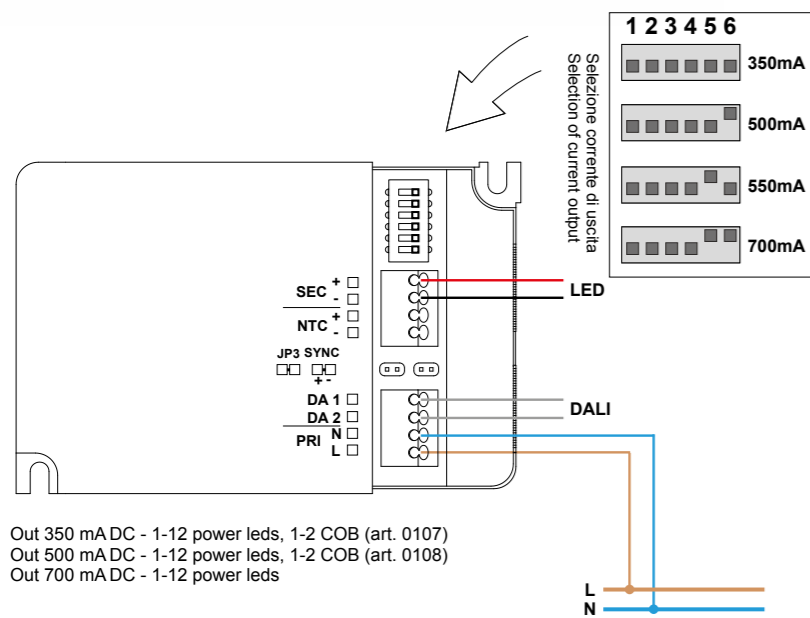

0145/DALI

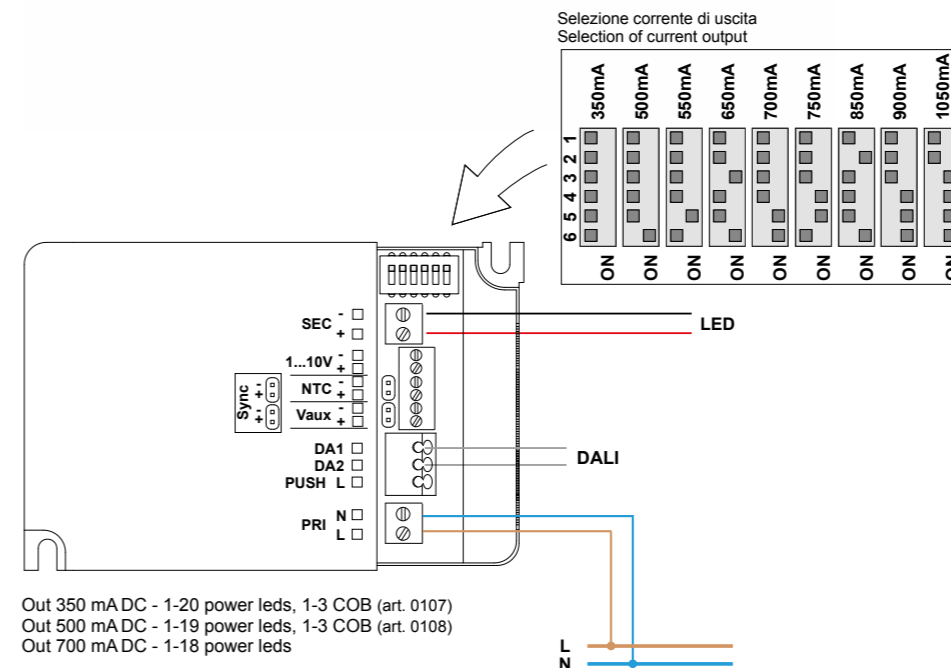

DIMMERAZIONE 12V - 24V PER LED STRIP

DIMMING 12V - 24V FOR LED STRIP

REGOLATORE DI LUMINOSITÀ PER DRIVER LED CON USCITA IN TENSIONE 12-24V DC.

Sono previste tre distinte modalità di funzionamento lette all'avvio (impostate tramite dip-switch prima dell'accensione):

- **DALI** - configurazione di fabbrica
Power ON: 100%
System fail level: 100%

- **PUSH** - impostazioni tramite DIP
Funzionamento regolazione:
pressione breve del tasto per ON/OFF;
pressione lunga del tasto per dimmer.
Memorizzazione dell'ultimo dato di dimming.
In presenza rete ad ogni ON il driver parte dall'ultimo dato impostato.

Procedura di allineamento (necessaria per compensare gli errori di sincronizzazione quando si hanno tanti driver in parallelo): da posizione ON/OFF tenere premuto il tasto a lungo (30 sec.) i driver si porteranno al 100%; alla successiva pressione del tasto il flusso luminoso inizierà a diminuire in accordo al profilo impostato.
Massima lunghezza totali cavi PUSH: 15 mt.

- **DIMMING 1...10V - 0...10V** - impostazioni tramite DIP

Utilizzo di dimmer attivi o passivi (impostazione tramite ponticello):
Impostare il ponticello sulla posizione A per potenziometri attivi e sistemi domotici: impedenza 130K.
Impostare il ponticello sulla posizione B per potenziometri passivi: Iout max 1,4mA.

LIGHT DIMMER FOR VOLTAGE LED DRIVER 12-24V DC

3 different modality available before activation (set by DIP switch before switch-on).

- **DALI** - factory preset.
Power ON: 100%
System fail level: 100%

- **PUSH** - setting by DIP
Regulation controls:
Short key push for on ON-OFF.
Long push for dimming:
Dimming memory sets on last dimming level.
When connected to main supply at each on-switching the driver will restart from last selected level.
Alignment procedure (required to compensate synchronization errors in case many drivers are connected in parallel):
from ON-OFF position hold the key pushed for a long time (30 sec.), all the drivers will go to 100%; at the next push light flux will decrease in conformity with selected setting.
Maximum cable length for PUSH 15 m.

- **DIMMING 1...10V or 0...10V** - setting by DIP
Use with active or passive dimmer (setting by jumper):
Position the jumper on A for active potentiometers or home-automation systems.
Impedance 130K.
Position the jumper on B for passive potentiometers: Iout max 1.4 mA.



0110/DIM **PUSH**

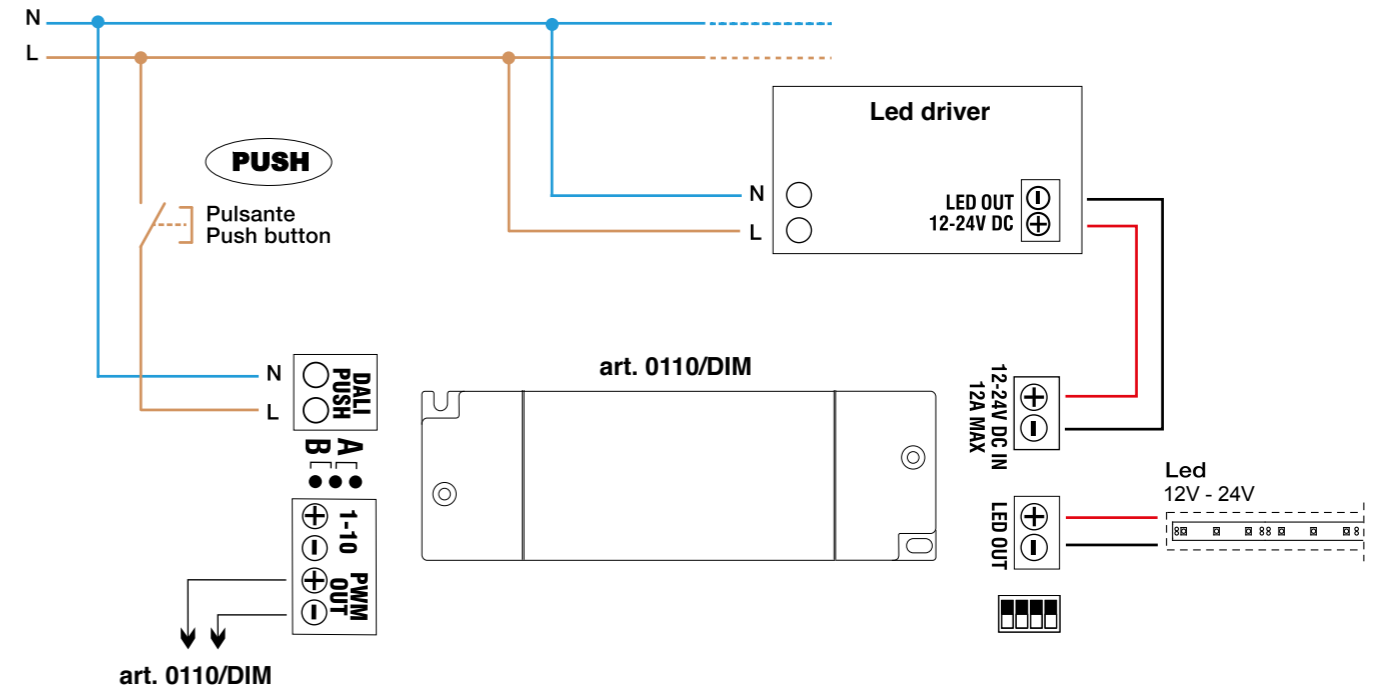

0110/DIM

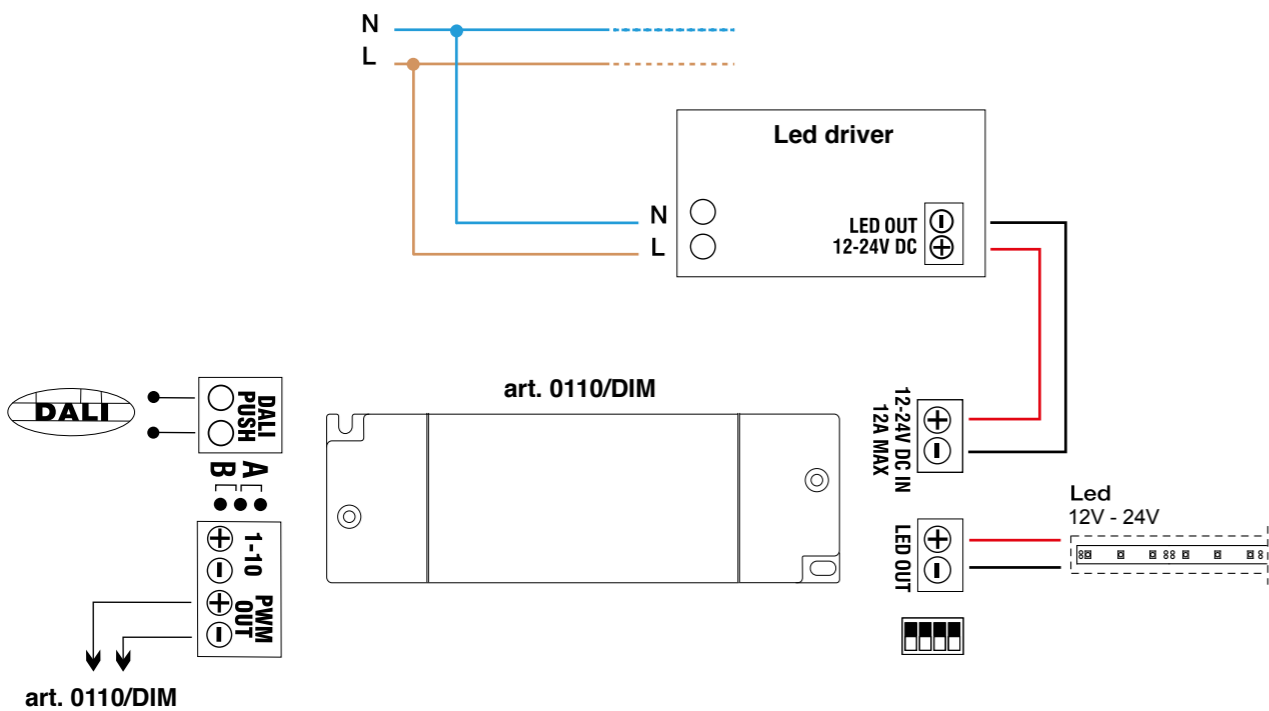

0110/DIM **1...10 V**

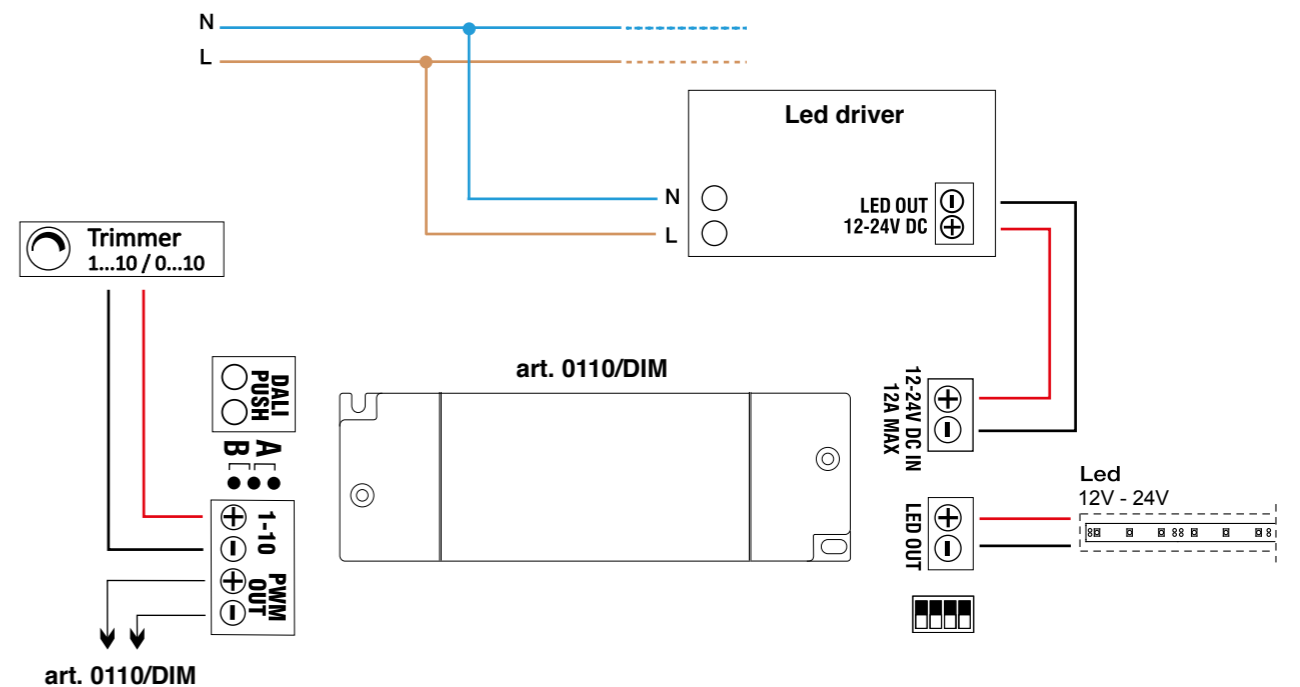

DIMMERAZIONE 24V PER LED STRIP

DIMMING 24V FOR LED STRIP

Technology



0717/DIM100

1) Ingresso DALI: selezionare il ponticello come indicato. Possibilità di collegare altri PBOX in parallelo attraverso il collegamento "Syncro".
 2) Ingresso 1...10V: selezionare il ponticello come indicato. Possibilità di collegare altri PBOX in parallelo attraverso il collegamento "Syncro".
 3) Ingresso Pulsante ON/OFF/Dimmer, selezionare il ponticello su "DALI" e attivare la memoria di stato. I collegamenti del pulsante sono in bassa tensione; mantenere isolamento dai collegamenti di rete
 Possibilità di collegare altri PBOX in parallelo attraverso il collegamento "Syncro".
 Togliere il ponticello a tutti i PBOX slave. Massimo 15 Slave.

1) Input DALI: set the jumper as indicated. Possible parallel connection of more PBOX through Synchro-Mode
 2) Input 1...10V: set the jumper as indicated. Possible parallel connection of more PBOX through Synchro-Mode
 3) Input for push ON/OFF/Dimmer: set the jumper on Memory. Connections of push-button in low voltage; keep them far from mains connections. Possible parallel connection of more PBOX through Synchro-Mode. Remove the jumper by all Slaves. Max 15 pcs in total.

0717/DIM100



220 - 240 Vac
50/60 Hz

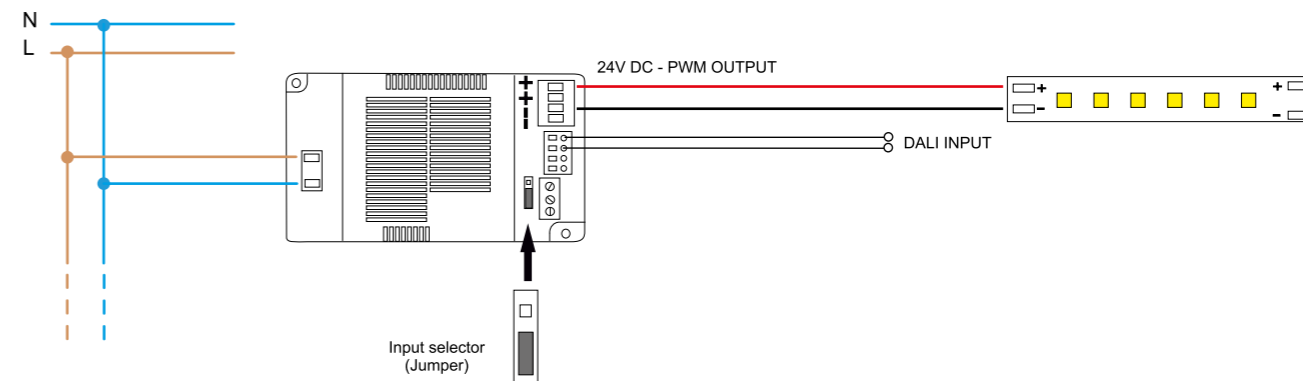

0717/DIM100



220 - 240 Vac
50/60 Hz

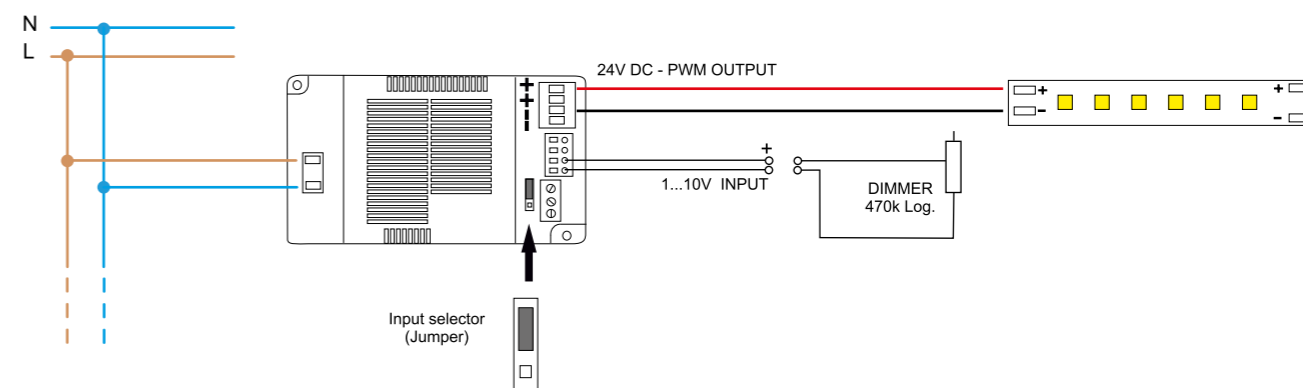

0717/DIM100



220 - 240 Vac
50/60 Hz

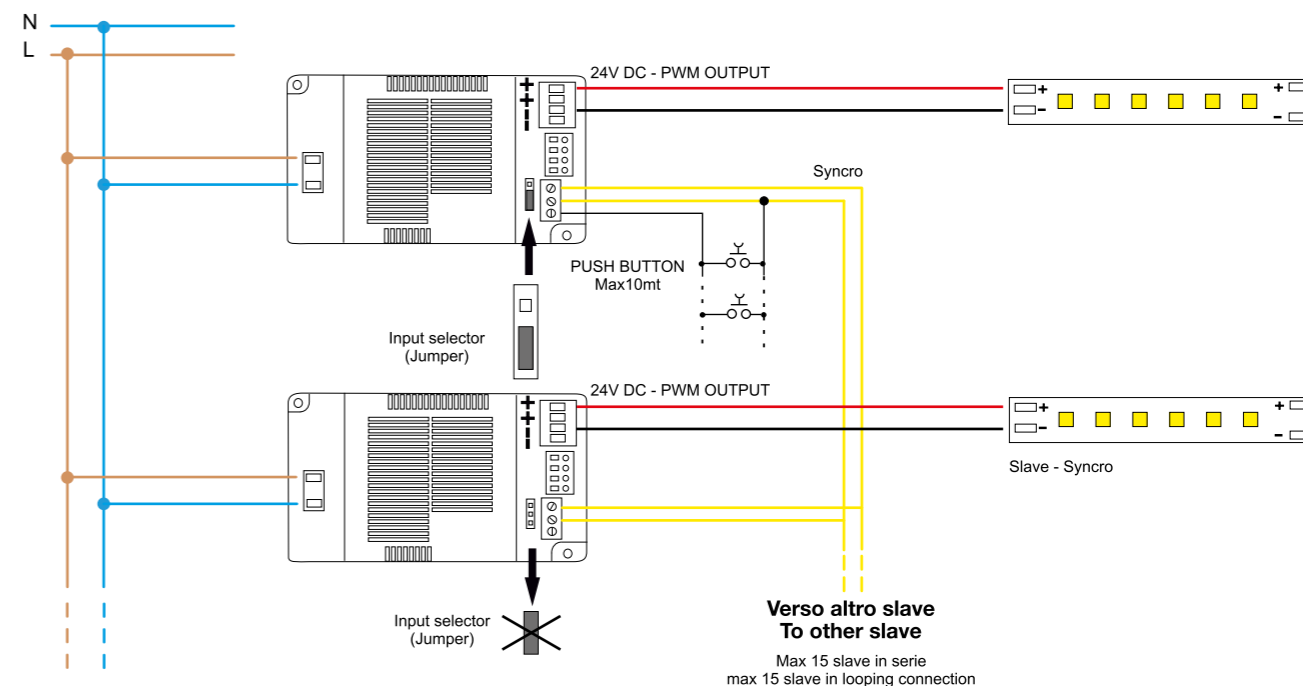

Technology

CONTROLLO RGB SMALL 22W

RGB CONTROL SMALL 22W

Technology



0167: alimentatore RGB master e slave
uscita: 3 canali a 24V (max. 22W).

0168: converter RGB
Ingresso 24V, uscita per moduli a 250mA
(max. 5 Led per canale).

0166: cavo di sincronizzazione

0165: telecomando IR

0163: ricevitore IR

0167: RGB master and slave controller
Output: 3 channels at 24V (max. 22W)

0168: RGB converter
Input: 24V, modules output 250mA
(max. 5 LED each channel)

0166: synchronization cable

0165: IR Remote controller

0163: IR Receiver

FUNZIONAMENTO REGOLAZIONE PUSH

• Pressione rapida da spento

accensione con colore fisso ulteriori brevi pressioni attivano le scene luminose secondo la sequenza: RGB-WRGB-BG-YGR

• Pressione prolungata da spento (>2 sec.)

attiva modalità scelta colore fisso; lentamente scorrono i colori, premendo brevemente si blocca scorrimento colori e una ulteriore pressione prolungata del tasto memorizza il colore e spegne il prodotto. Il colore scelto si ripresenterà come primo colore ad ogni accensione prodotto.

• Pressione prolungata spegne il prodotto.

HOW TO SELECT FUNCTIONS WITH PUSH BUTTON

• Short push with switched-off product

Product will switch-on on a preselected fixed color, further short pushes will activate different lighting scenes following the sequence: RGB-WRGB-BG-YGR.

• Long push with switched-off product (>2 sec.)

will activate choice of preselected fix color; colors changes slowly, a short push will stop on a selected color; a second long push will memorize this as preselected and then the product will switch off. Preselected color will be displayed as first any time you switch on the product.

• Long push with product switched on will switch off.

FUNZIONAMENTO TELECOMANDO

• Tasti regolazione singolo colore

Premendo uno dei tasti colore si dimmerà il canale corrispondente.

Se il canale (colore) non è alla massima intensità premendo il tasto si avrà un incremento di questa fino al massimo o fino al livello corrispondente al momento in cui si rilascia il tasto.

Un'ulteriore pressione del tasto inverte il verso di regolazione fino al totale spegnimento del canale o fino al livello corrispondente al momento in cui si rilascia il tasto.

Se il canale (colore) è alla massima intensità premendo il tasto si avrà un decremento di questa fino allo spegnimento completo o fino al livello corrispondente al momento in cui si rilascia il tasto. Se si è nella funzione show, premere uno di questi tasti termina la funzione bloccando i colori nella condizione di quell'istante.

Il tasto colore bianco regola l'intensità dei tre canali simultaneamente con la stessa modalità del singolo colore.

• Tasti tempo ciclo

Sono disponibili i seguenti tasti: 30sec, 2min., 10min. Premere il tasto corrispondente al tempo ciclo desiderato.

• Tasto Show

Permette la selezione di uno dei 4 show preimpostati: premendo il tasto si può scegliere lo show dal primo colore della sequenza. Il tempo ciclo è di default 30 sec.

• Tasto accensione /spegnimento stand by

Permette l'accensione e lo spegnimento del prodotto mettendolo in modalità stand by: alla prima accensione del prodotto i 3 canali saranno accesi alla massima intensità. Per le accensioni successive i canali saranno accesi all'intensità memorizzata allo spegnimento del prodotto.

REMOTE FUNCTIONS

• Single colour selection buttons

Pushing one of those buttons dims corresponding channel (color).

If the channel(color) is not at the max intensity, by pushing the button intensity will go up to maximum power or till the level reached when the button is released.

A further push of the button will invert regulation mode and the intensity will fade up to total switch-off or till the level reached when the button is released.

If the channel(color) is at the max intensity, the intensity will fade up to total switch-off or till the level reached when the button is released. If the show function is activated, pushing one of those buttons will terminate the show fixing the colors as they are.

The white button dims all three channels simultaneously following same modality of color buttons.

• Cycle timing buttons

Following buttons are available: 30sec, 2min., 10 min. Push the button corresponding at the desired cycle timing:

• Show button

It allows selection among the 4 preset programs: first colour in a sequence can be selected by pushing this button. Default cycle duration is 30 sec.

• Switch on/off and stand-by button

Controls on-off switching of the product activating standby mode: when switching on the product for the first time the 3 channels will activate at max power. After that each channel will switch-on at the intensity memorized during switch-off.

RGB push (22W)

220/240 Vac
50/60 Hz

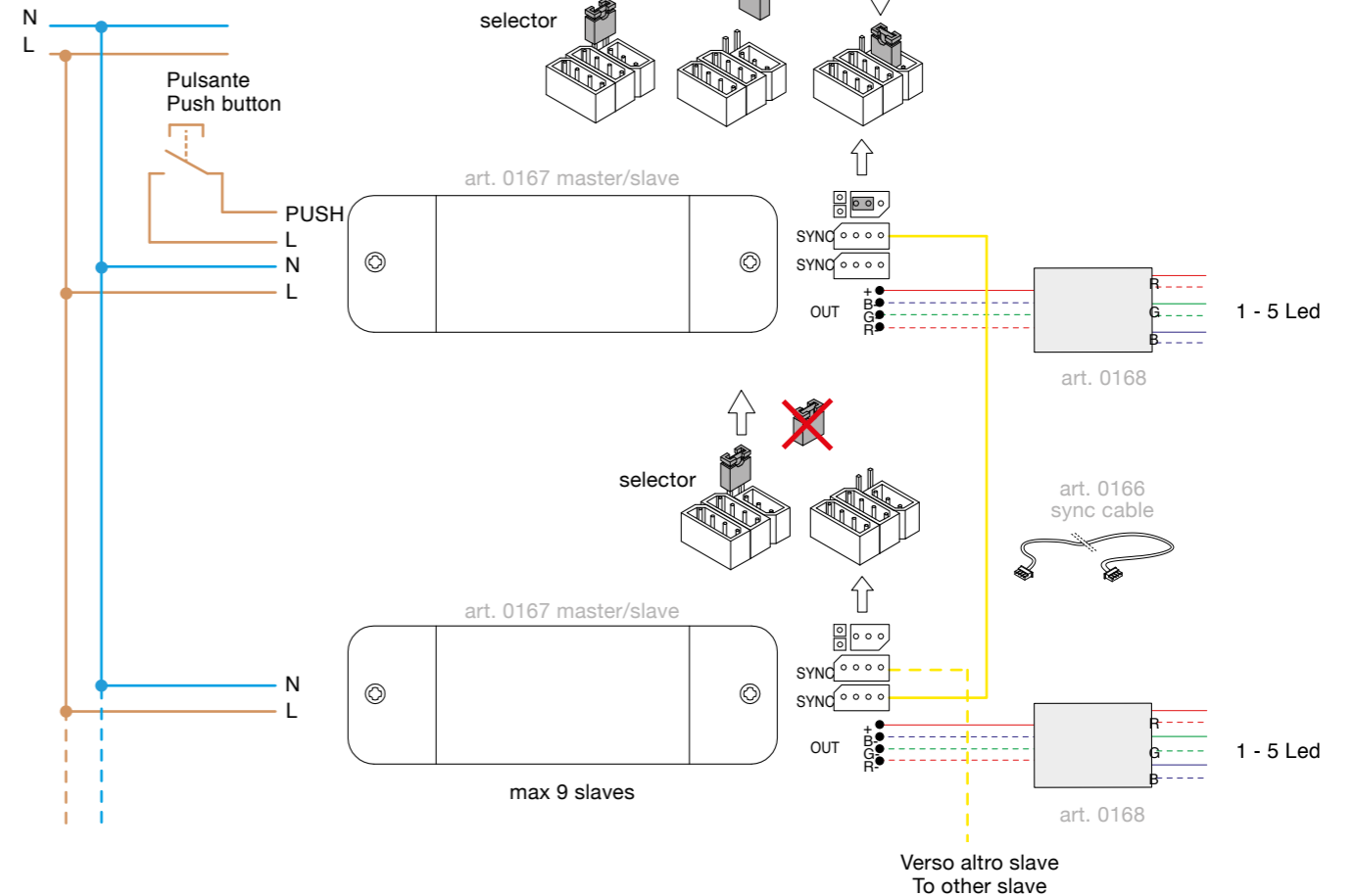

RGB remote (22W)

220/240 Vac
50/60 Hz

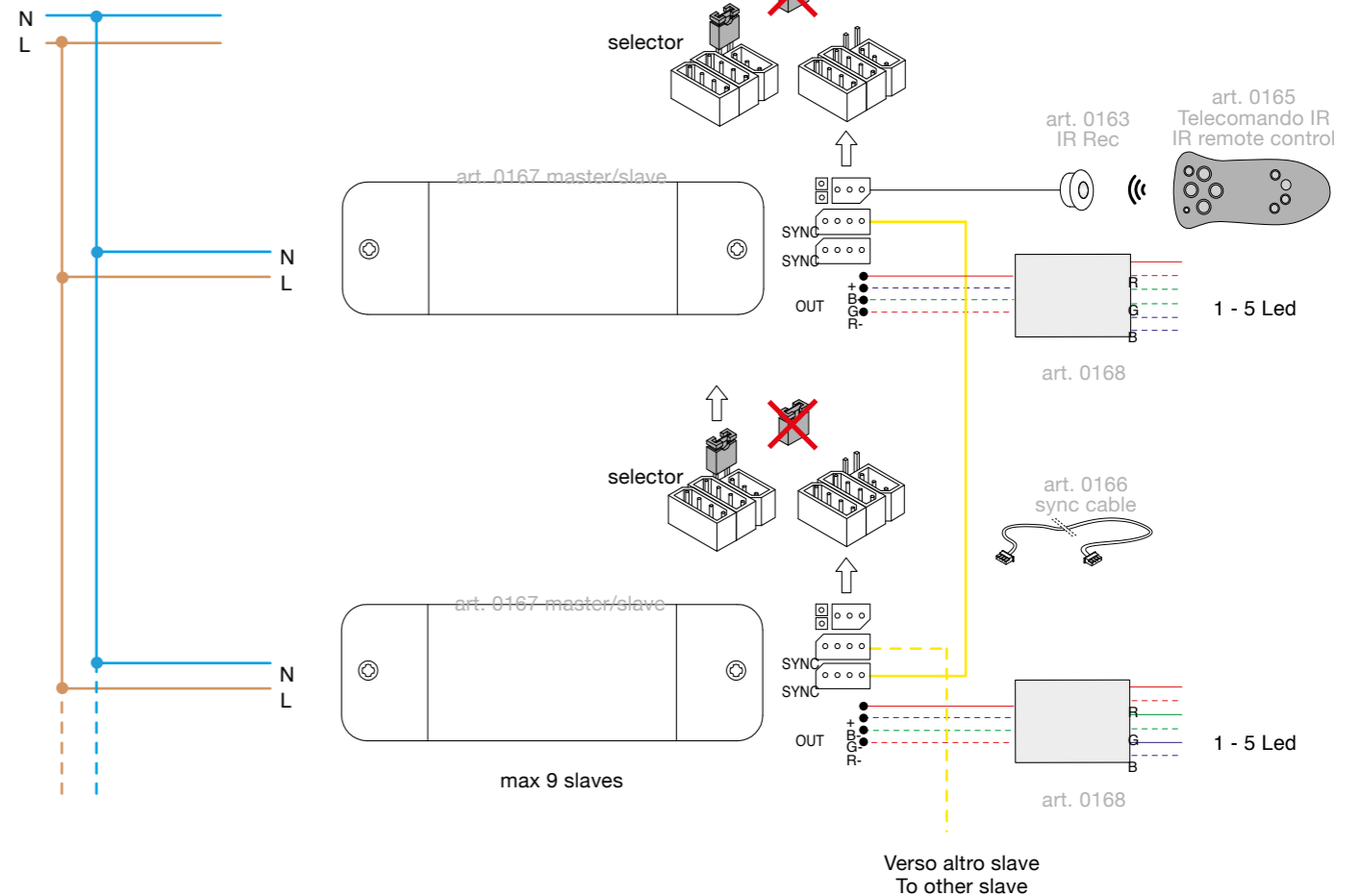

Technology

CONTROLLO RGB BIG 120W

RGB CONTROL BIG 120W



- 0164: alimentatore RGB master e slave uscita: 3 canali a 24V (max. 120W).
- 0168: converter RGB Ingresso 24V, uscita per moduli a 250mA (max. 5 Led per canale).
- 0166: cavo di sincronizzazione
- 0165: telecomando IR
- 0163: ricevitore IR

- 0164: RGB master and slave controller Output: 3 channels at 24V (max. 120W)
- 0168: RGB converter Input: 24V, modules output 250mA (max. 5 LED each channel)
- 0166: synchronization cable
- 0165: IR Remote control
- 0163: IR Receiver

FUNZIONAMENTO REGOLAZIONE PUSH

- **Pressione rapida da spento**
accensione con colore fisso ulteriori brevi pressioni attivano le scene luminose secondo la sequenza: RGB-WRGB-BG-YGR
- **Pressione prolungata da spento (>2 sec.)**
attiva modalità scelta colore fisso; lentamente scorrono i colori, premendo brevemente si blocca scorrimento colori e una ulteriore pressione prolungata del tasto memorizza il colore e spegne il prodotto. Il colore scelto si ripresenterà come primo colore ad ogni accensione prodotto.
- **Pressione prolungata spegne il prodotto.**

HOW TO SELECT FUNCTIONS WITH PUSH BUTTON

- **Short push with switched-off product**
Product will switch-on on a preselected fixed color, further short pushes will activate different lighting scenes following the sequence: RGB-WRGB-BG-YGR.
- **Long push with switched-off product (>2 sec.)**
will activate choice of preselected fix color; colors changes slowly, a short push will stop on a selected color; a second long push will memorize this as preselected and then the product will switch off. Preselected color will be displayed as first any time you switch on the product.
- **Long push with product switched on will switch off.**

FUNZIONAMENTO TELECOMANDO

- **Tasti regolazione singolo colore**
Premendo uno dei tasti colore si dimmerà il canale corrispondente. Se il canale (colore) non è alla massima intensità premendo il tasto si avrà un incremento di questa fino al massimo o fino al livello corrispondente al momento in cui si rilascia il tasto. Un'ulteriore pressione del tasto inverte il verso di regolazione fino al totale spegnimento del canale o fino al livello corrispondente al momento in cui si rilascia il tasto. Se il canale (colore) è alla massima intensità premendo il tasto si avrà un decremento di questa fino allo spegnimento completo o fino al livello corrispondente al momento in cui si rilascia il tasto. Se si è nella funzione show, premere uno di questi tasti termina la funzione bloccando i colori nella condizione di quell'istante. Il tasto colore bianco regola l'intensità dei tre canali simultaneamente con la stessa modalità del singolo colore.
- **Tasti tempo ciclo**
Sono disponibili i seguenti tasti: 30sec, 2min., 10min. Premere il tasto corrispondente al tempo ciclo desiderato.
- **Tasto Show**
Permette la selezione di uno dei 4 show preimpostati: premendo il tasto si può scegliere lo show dal primo colore della sequenza. Il tempo ciclo è di default 30 sec.
- **Tasto accensione /spegnimento stand by**
Permette l'accensione e lo spegnimento del prodotto mettendolo in modalità stand by: alla prima accensione del prodotto i 3 canali saranno accesi alla massima intensità. Per le accensioni successive i canali saranno accesi all'intensità memorizzata allo spegnimento del prodotto.

REMOTE FUNCTIONS

- **Single colour selection buttons**
Pushing one of those buttons dims corresponding channel (color). If the channel(color) is not at the max intensity, by pushing the button intensity will go up to maximum power or till the level reached when the button is released. A further push of the button will invert regulation mode and the intensity will fade up to total switch-off or till the level reached when the button is released. If the show function is activated, pushing one of those buttons will terminate the show fixing the colors as they are. The white button dims all three channels simultaneously following same modality of color buttons.
- **Cycle timing buttons**
Following buttons are available: 30sec, 2min., 10 min. Push the button corresponding at the desired cycle timing:
- **Show button**
It allows selection among the 4 preset programs: first colour in a sequence can be selected by pushing this button. Default cycle duration is 30 sec.
- **Switch on/off and stand-by button**
Controls on-off switching of the product activating standby mode: when switching on the product for the first time the 3 channels will activate at max power. After that each channel will switch-on at the intensity memorized during switch-off.

RGB push (120W)

220/240 Vac
50/60 Hz

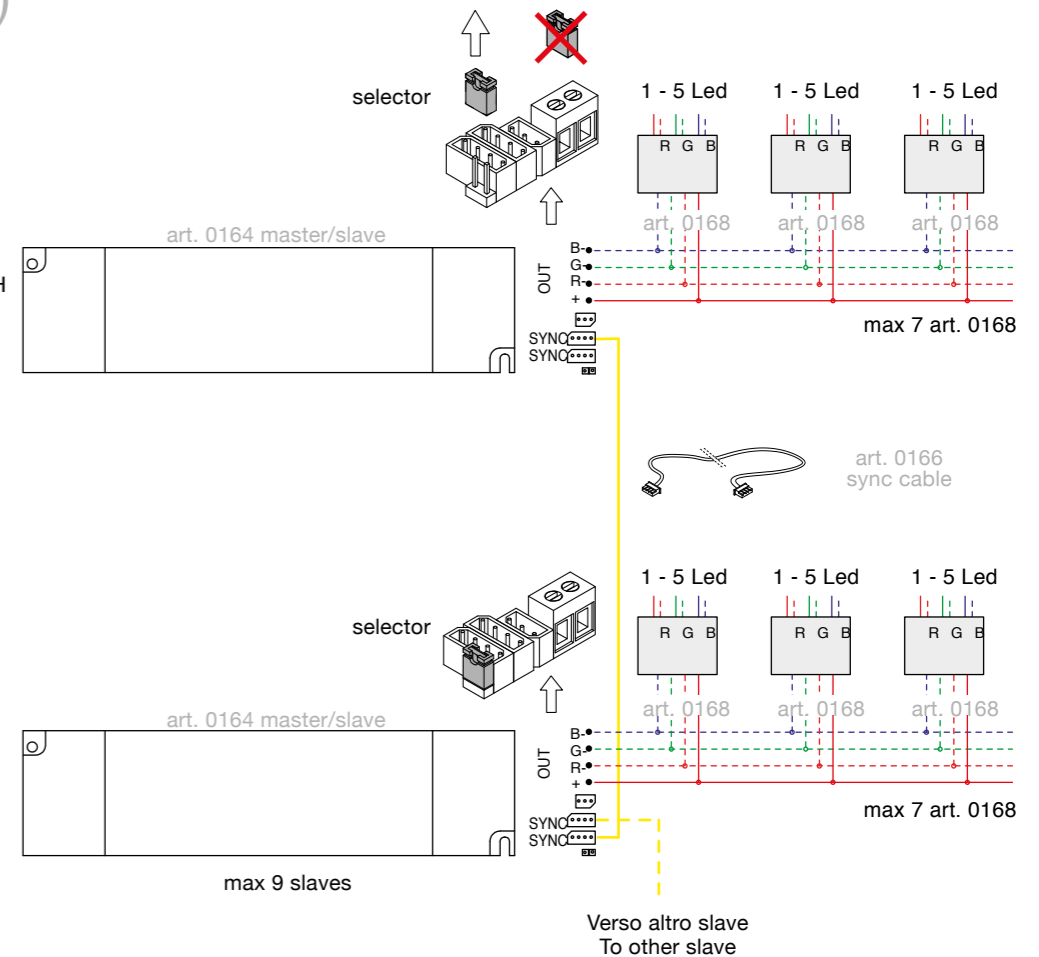
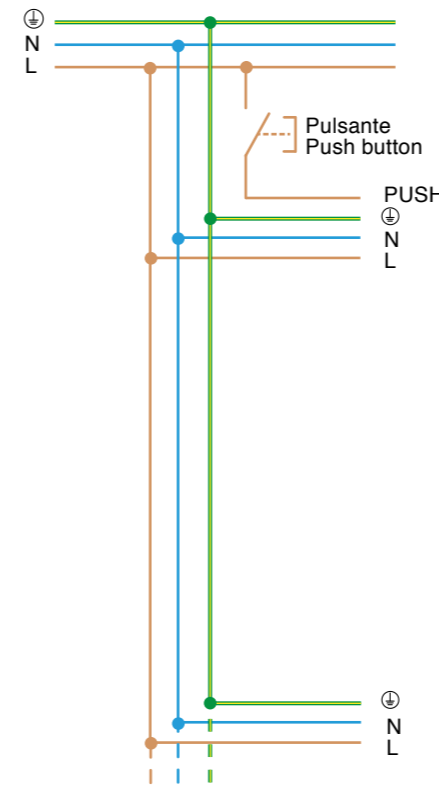

RGB remote (120W)

220/240 Vac
50/60 Hz

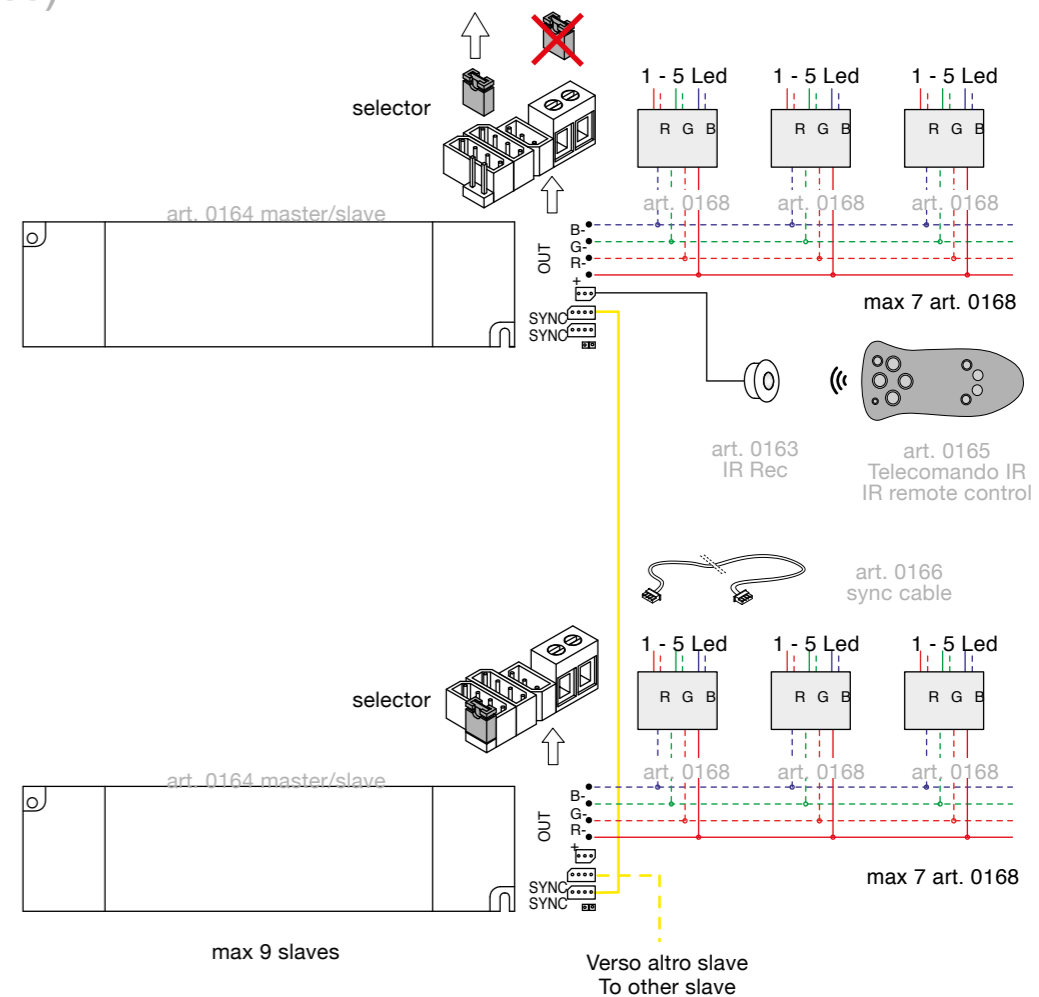
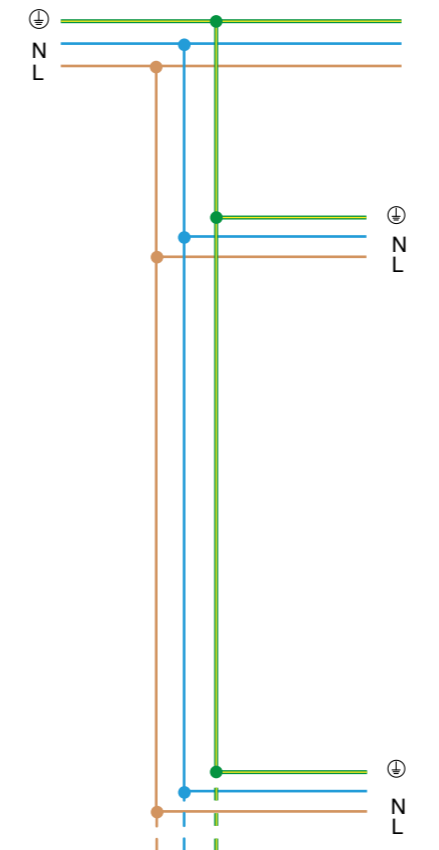

CONTROLLO RGB PER LED STRIP SMALL 22W

RGB CONTROL SMALL 22W FOR LED STRIP

0167: alimentatore RGB master e slave
uscita: 3 canali a 24V (max. 22W).

0166: cavo di sincronizzazione

0165: telecomando IR

0163: ricevitore IR

0167: RGB master and slave controller
Output: 3 channels at 24V (max. 22W)

0166: synchronization cable

0165: IR Remote control

0163: IR Receiver



FUNZIONAMENTO REGOLAZIONE PUSH

• Pressione rapida da spento

accensione con colore fisso ulteriori brevi pressioni attivano le scene luminose secondo la sequenza: RGB-WRGB-BG-YGR

• Pressione prolungata da spento (>2 sec.)

attiva modalità scelta colore fisso; lentamente scorrono i colori, premendo brevemente si blocca scorrimento colori e una ulteriore pressione prolungata del tasto memorizza il colore e spegne il prodotto. Il colore scelto si ripresenterà come primo colore ad ogni accensione prodotto.

• Pressione prolungata spegne il prodotto.

HOW TO SELECT FUNCTIONS WITH PUSH BUTTON

• Short push with switched-off product

Product will switch-on on a preselected fixed color, further short pushes will activate different lighting scenes following the sequence: RGB-WRGB-BG-YGR.

• Long push with switched-off product (>2 sec.)

will activate choice of preselected fix color; colors changes slowly, a short push will stop on a selected color; a second long push will memorize this as preselected and then the product will switch off. Preselected color will be displayed as first any time you switch on the product.

• Long push with product switched on will switch off.

FUNZIONAMENTO TELECOMANDO

• Tasti regolazione singolo colore

Premendo uno dei tasti colore si dimmerà il canale corrispondente. Se il canale (colore) non è alla massima intensità premendo il tasto si avrà un incremento di questa fino al massimo o fino al livello corrispondente al momento in cui si rilascia il tasto.

Un'ulteriore pressione del tasto inverte il verso di regolazione fino al totale spegnimento del canale o fino al livello corrispondente al momento in cui si rilascia il tasto.

Se il canale (colore) è alla massima intensità premendo il tasto si avrà un decremento di questa fino allo spegnimento completo o fino al livello corrispondente al momento in cui si rilascia il tasto. Se si è nella funzione show, premere uno di questi tasti termina la funzione bloccando i colori nella condizione di quell'istante.

Il tasto colore bianco regola l'intensità dei tre canali simultaneamente con la stessa modalità del singolo colore.

• Tasti tempo ciclo

Sono disponibili i seguenti tasti: 30sec, 2min., 10min. Premere il tasto corrispondente al tempo ciclo desiderato.

• Tasto Show

Permette la selezione di uno dei 4 show preimpostati: premendo il tasto si può scegliere lo show dal primo colore della sequenza. Il tempo ciclo è di default 30 sec.

• Tasto accensione /spegnimento stand by

Permette l'accensione e lo spegnimento del prodotto mettendolo in modalità stand by: alla prima accensione del prodotto i 3 canali saranno accesi alla massima intensità. Per le accensioni successive i canali saranno accesi all'intensità memorizzata allo spegnimento del prodotto.

REMOTE FUNCTIONS

• Single colour selection buttons

Pushing one of those buttons dims corresponding channel (color).

If the channel(color) is not at the max intensity, by pushing the button intensity will go up to maximum power or till the level reached when the button is released.

A further push of the button will invert regulation mode and the intensity will fade up to total switch-off or till the level reached when the button is released.

If the channel(color) is at the max intensity, the intensity will fade up to total switch-off or till the level reached when the button is released. If the show function is activated, pushing one of those buttons will terminate the show fixing the colors as they are.

The white button dims all three channels simultaneously following same modality of color buttons.

• Cycle timing buttons

Following buttons are available: 30sec, 2min., 10min. Push the button corresponding at the desired cycle timing:

• Show button

It allows selection among the 4 preset programs: first colour in a sequence can be selected by pushing this button. Default cycle duration is 30 sec.

• Switch on/off and stand-by button

Controls on-off switching of the product activating standby mode: when switching on the product for the first time the 3 channels will activate at max power. After that each channel will switch-on at the intensity memorized during switch-off.

RGB push (22W)

220/240 Vac
50/60 Hz

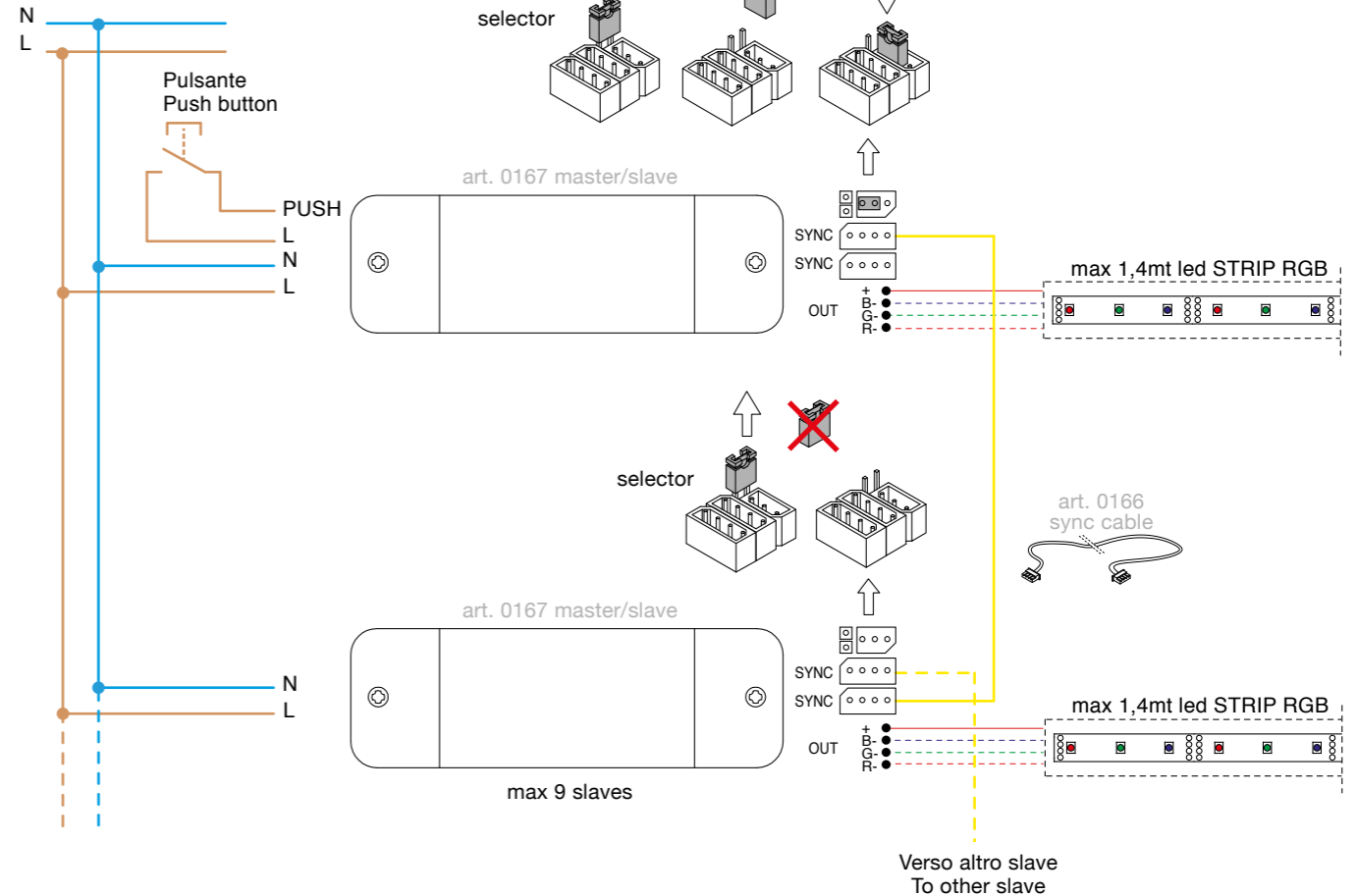

RGB remote (22W)

220/240 Vac
50/60 Hz

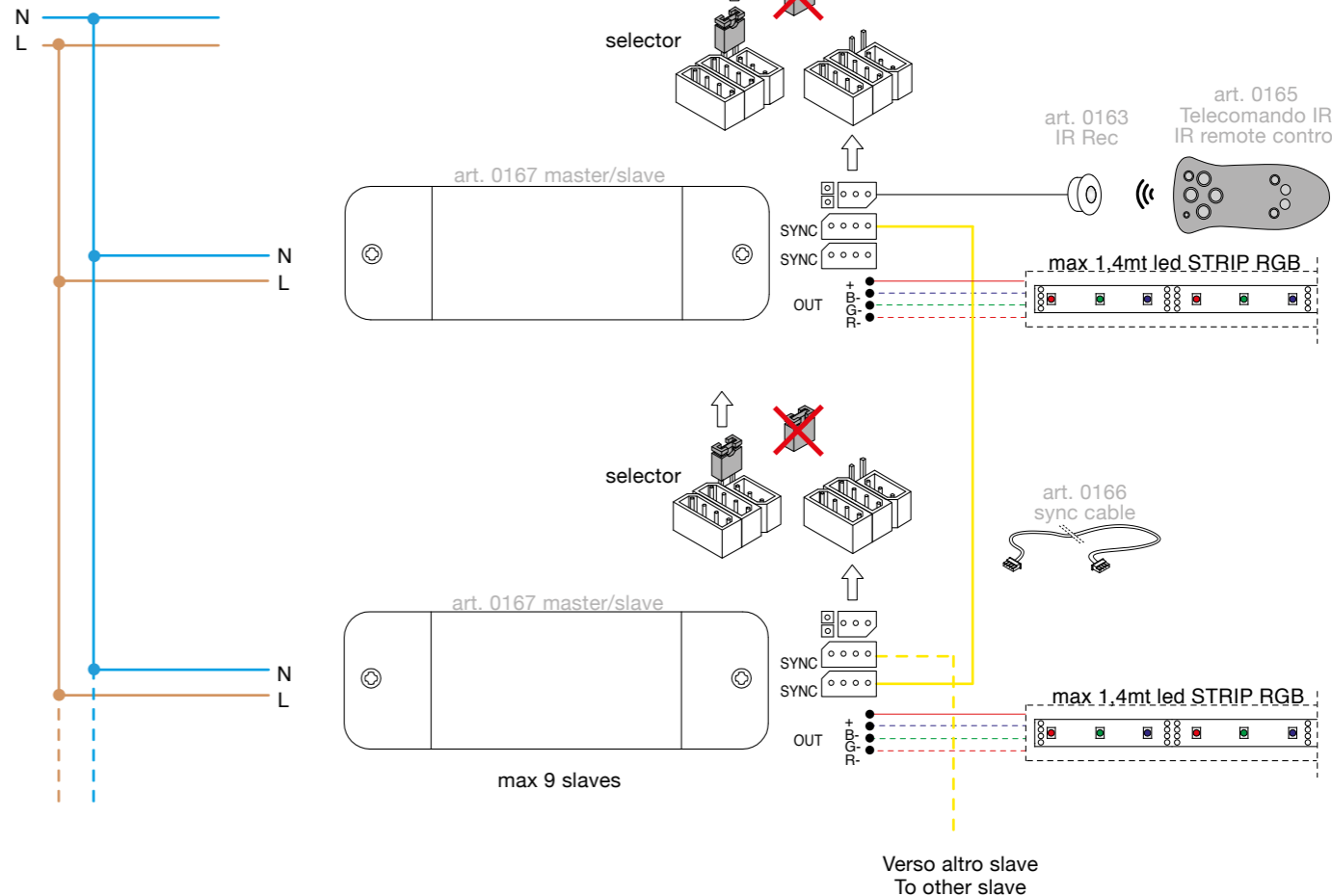

CONTROLLO RGB PER LED STRIP BIG 120W

RGB CONTROL BIG 120W FOR LED STRIP

- 0164: alimentatore RGB master e slave uscita: 3 canali a 24V (max. 120W).
- 0166: cavo di sincronizzazione
- 0165: telecomando IR
- 0163: ricevitore IR

- 0164: RGB master and slave controller Output: 3 channels at 24V (max. 120W)
- 0166: synchronization cable
- 0165: IR Remote control
- 0163: IR Receiver



FUNZIONAMENTO REGOLAZIONE PUSH

- **Pressione rapida da spento**
accensione con colore fisso ulteriori brevi pressioni attivano le scene luminose secondo la sequenza: RGB-WRGB-BG-YGR

- **Pressione prolungata da spento (>2 sec.)**
attiva modalità scelta colore fisso; lentamente scorrono i colori, premendo brevemente si blocca scorrimento colori e una ulteriore pressione prolungata del tasto memorizza il colore e spegne il prodotto. Il colore scelto si ripresenterà come primo colore ad ogni accensione prodotto.

- **Pressione prolungata spegne il prodotto.**

HOW TO SELECT FUNCTIONS WITH PUSH BUTTON

- **Short push with switched-off product**
Product will switch-on on a preselected fixed color, further short pushes will activate different lighting scenes following the sequence: RGB-WRGB-BG-YGR.

- **Long push with switched-off product (>2 sec.)**
will activate choice of preselected fix color; colors changes slowly, a short push will stop on a selected color; a second long push will memorize this as preselected and then the product will switch off. Preselected color will be displayed as first any time you switch on the product.

- **Long push with product switched on will switch off.**

FUNZIONAMENTO TELECOMANDO

- **Tasti regolazione singolo colore**
Premendo uno dei tasti colore si dimmerà il canale corrispondente. Se il canale (colore) non è alla massima intensità premendo il tasto si avrà un incremento di questa fino al massimo o fino al livello corrispondente al momento in cui si rilascia il tasto. Un'ulteriore pressione del tasto inverte il verso di regolazione fino al totale spegnimento del canale o fino al livello corrispondente al momento in cui si rilascia il tasto. Se il canale (colore) è alla massima intensità premendo il tasto si avrà un decremento di questa fino allo spegnimento completo o fino al livello corrispondente al momento in cui si rilascia il tasto. Se si è nella funzione show, premere uno di questi tasti termina la funzione bloccando i colori nella condizione di quell'istante. Il tasto colore bianco regola l'intensità dei tre canali simultaneamente con la stessa modalità del singolo colore.

- **Tasti tempo ciclo**
Sono disponibili i seguenti tasti: 30sec, 2min., 10min. Premere il tasto corrispondente al tempo ciclo desiderato.

- **Tasto Show**
Permette la selezione di uno dei 4 show preimpostati: premendo il tasto si può scegliere lo show dal primo colore della sequenza. Il tempo ciclo è di default 30 sec.

- **Tasto accensione /spegnimento stand by**
Permette l'accensione e lo spegnimento del prodotto mettendolo in modalità stand by: alla prima accensione del prodotto i 3 canali saranno accesi alla massima intensità. Per le accensioni successive i canali saranno accesi all'intensità memorizzata allo spegnimento del prodotto.

REMOTE FUNCTIONS

- **Single colour selection buttons**
Pushing one of those buttons dims corresponding channel (color). If the channel(color) is not at the max intensity, by pushing the button intensity will go up to maximum power or till the level reached when the button is released. A further push of the button will invert regulation mode and the intensity will fade up to total switch-off or till the level reached when the button is released. If the channel(color) is at the max intensity, the intensity will fade up to total switch-off or till the level reached when the button is released. If the show function is activated, pushing one of those buttons will terminate the show fixing the colors as they are. The white button dims all three channels simultaneously following same modality of color buttons.

- **Cycle timing buttons**
Following buttons are available: 30sec, 2min., 10 min. Push the button corresponding at the desired cycle timing:

- **Show button**
It allows selection among the 4 preset programs: first colour in a sequence can be selected by pushing this button. Default cycle duration is 30 sec.

- **Switch on/off and stand-by button**
Controls on-off switching of the product activating standby mode: when switching on the product for the first time the 3 channels will activate at max power. After that each channel will switch-on at the intensity memorized during switch-off.

RGB push (120W)

220/240 Vac
50/60 Hz

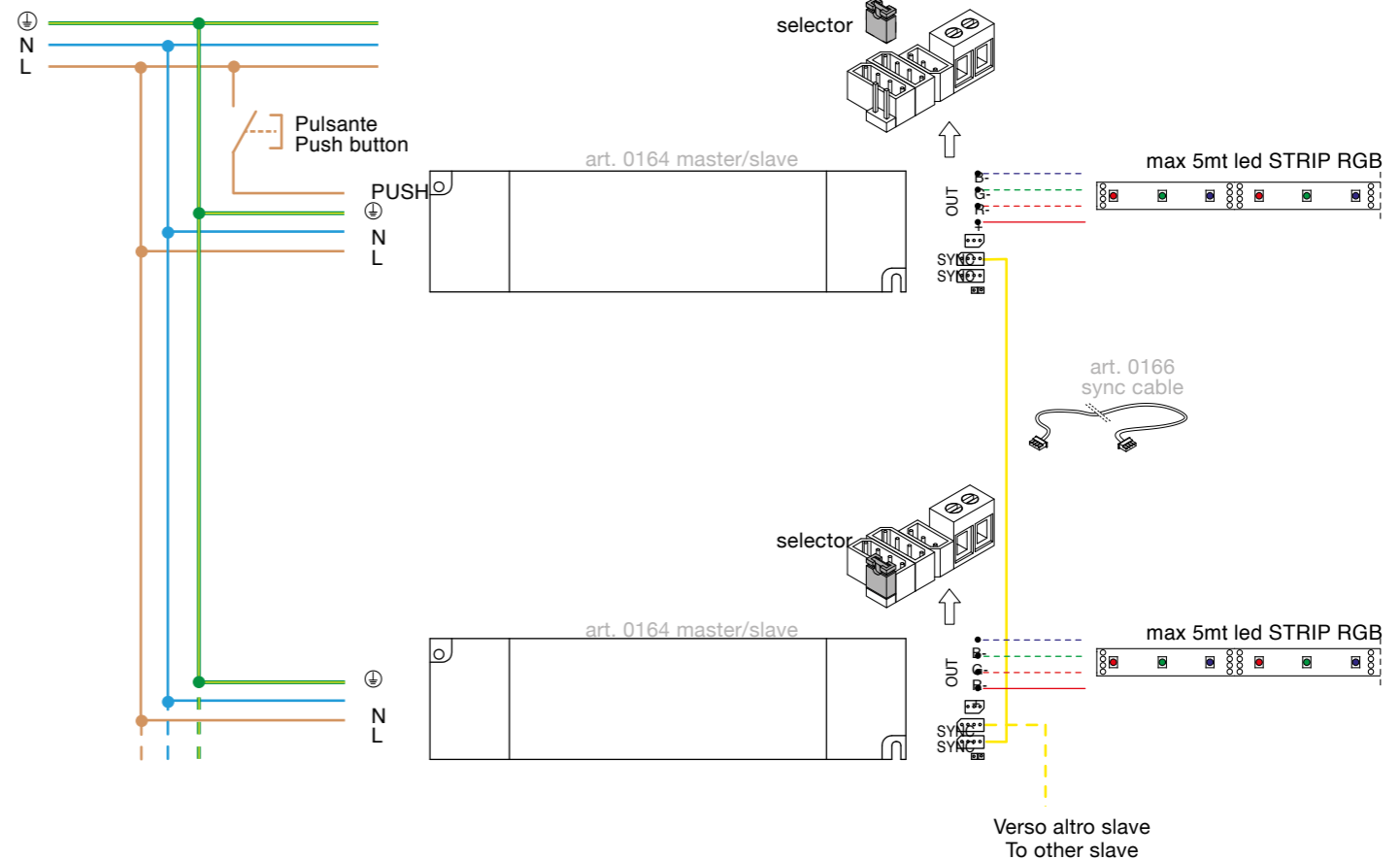

RGB remote (120W)

220/240 Vac
50/60 Hz

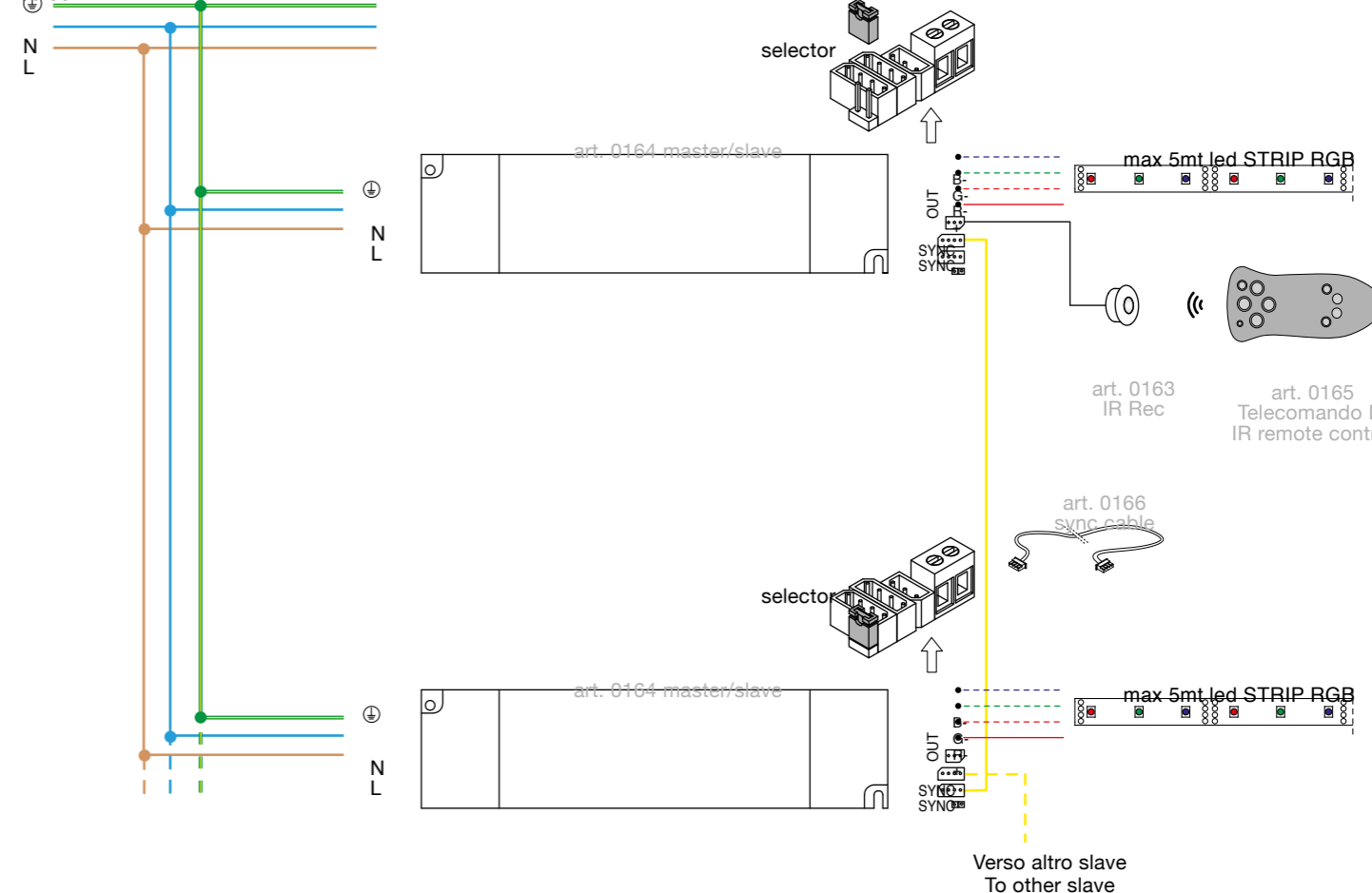

INTERFACCIA DMX - RGB

DMX - RGB INTERFACE

Technology



0729/DMX

Caratteristiche

- Interfaccia in grado di convertire il segnale con protocollo DMX in tre segnali PWM separati.
- Selezione indirizzo DMX tramite tre selettori rotativi posti sulla parte superiore dell'interfaccia.
- E' possibile inoltre utilizzare un unico cavo di sincronizzazione multicanale RGB (art.0166 fornito separatamente) per connettere fino a 10 alimentatori art. 0164, 0167.
- Il convertitore può essere alimentato direttamente dalla rete (100 ÷ 240 VAC).
- DMX mode tramite morsetti per collegamento basato su protocollo DMX512A standard. Selettori rotativi tipo BCD per impostazione indirizzi e inserimento resistenza di terminazione linea.
- LED per indicazione dello stato della trasmissione DMX e velocità show.

Features

- Interface which can convert a signal with DMX protocol into three separated PWM signal.
- DMX address selection through 3 selectors on the upper side of the interface.
- It is possible to use one RGB multichannel sync cable (art.0166 supplied separated) to connect up to 10 drivers of 0164,0167
- The converter can be powered directly from the mains (100 ÷ 240 VAC). DMX mode based on DMX 512A Standard. BCD rotary switch for setting DMX address and line termination resistor.
- LED indicator of the state of DMX transmission and show speed.

0729/DMX + Art. 0167

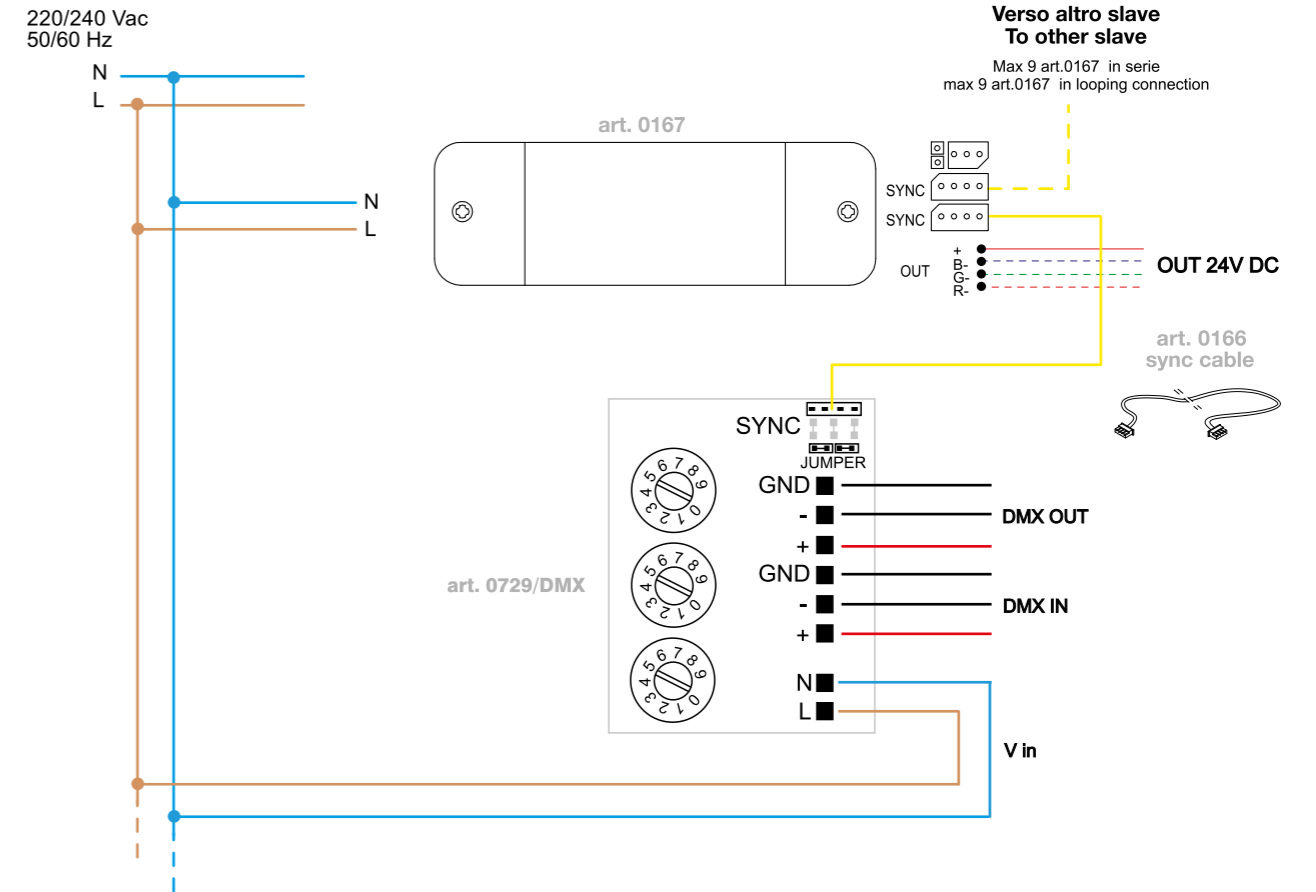

0729/DMX + Art. 0164

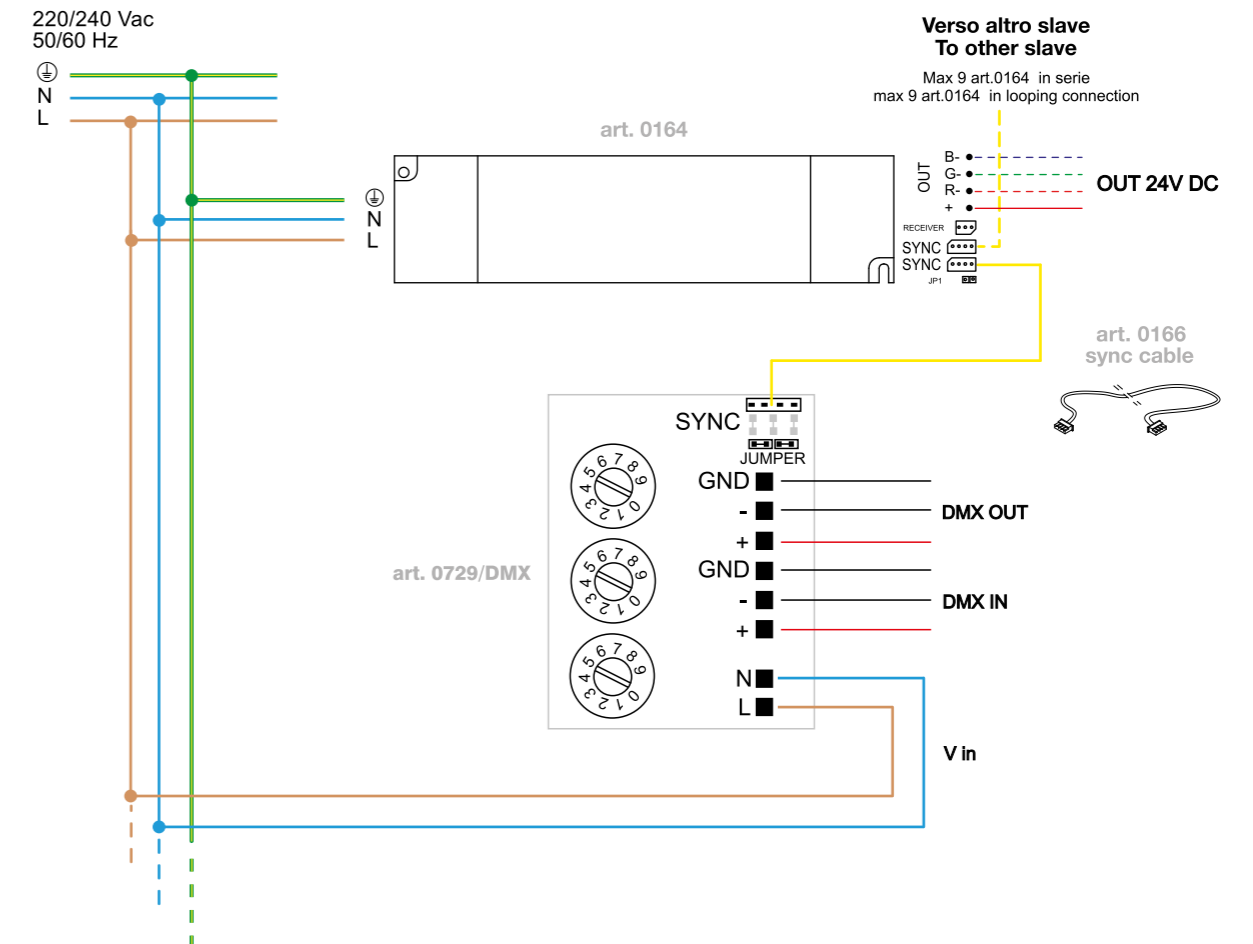

Technology

CONTROLLO EMERGENZA LED

LED EMERGENCY CONTROL



0115/EM (1h.) - 0115/EM/3 (3h.)

Gli alimentatori elettronici per illuminazione d'emergenza a funzionamento intermittente sono predisposti per alimentare LED di potenza (controllati in corrente) o moduli led (controllati in tensione) con la normale tensione di rete (220-240V - 50/60Hz), possono essere collegati per funzionamento permanente o non permanente, con qualsiasi tipo di alimentatore elettronico per LED. Tutti i modelli sono dotati di accumulatori ermetici al Ni-Cd in grado di garantire elevati rendimenti anche con alte temperature.

Caratteristiche tecniche:

- tensione di alimentazione: 220÷240V - 50/60Hz
- tempo di funzionamento in emergenza: 1h o 3h
- tempo di ricarica: 24h
- collegabili ad alimentatori con tensione massima in uscita 90V, corrente massima in uscita 2A

Collegamenti:

per non danneggiare i led collegare nell'ordine:

- sorgente LED
- cavo batteria
- alimentazione di rete

non scollegare e ricollegare i LED con emergenza in funzione.

The electronic units for emergency lighting are suitable for power LED (current controlled) or LED modules (voltage controlled). They can be used indifferently for maintained (main, 220/240V - 50/60Hz, in combination with LED electronic driver), or emergency operation. All the models have sealed Ni-Cd batteries able to guarantee high efficiency with high temperatures.

Technical characteristics:

- supply voltage: 220÷240V - 50/60Hz
- emergency light working time: 1h or 3h
- recharging time: 24h
- connected to power supplies 90V maximum output voltage 2A maximum output current

Wiring:

to not cause LED damage, please connect following this order:

- LED source
- battery cable
- mains connection

do not disconnect and connect the LED source during emergency operation.

0115/EM (1h.) - 0115/EM/3 (3h.)

Non permanente (solo emergenza) - Non-maintained (emergency only)

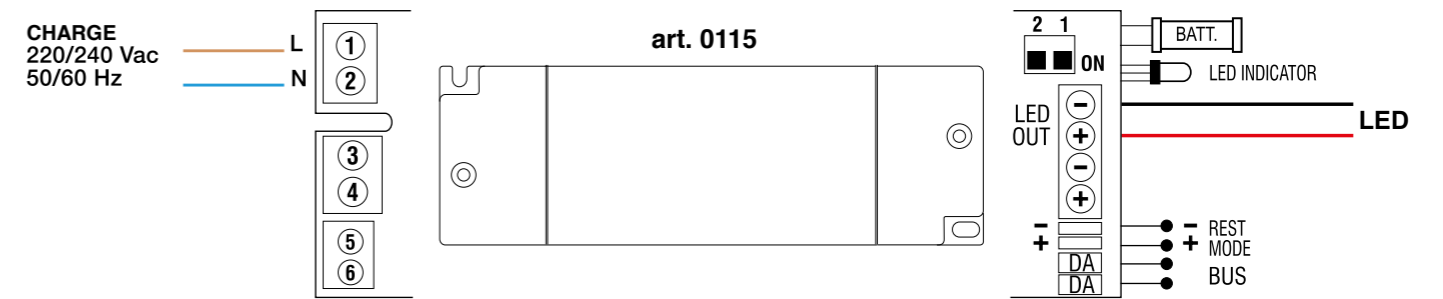

0115/EM (1h.) - 0115/EM/3 (3h.)

Permanente con alimentatore elettronico esterno (illuminazione ordinaria) - Maintained with external electronic driver

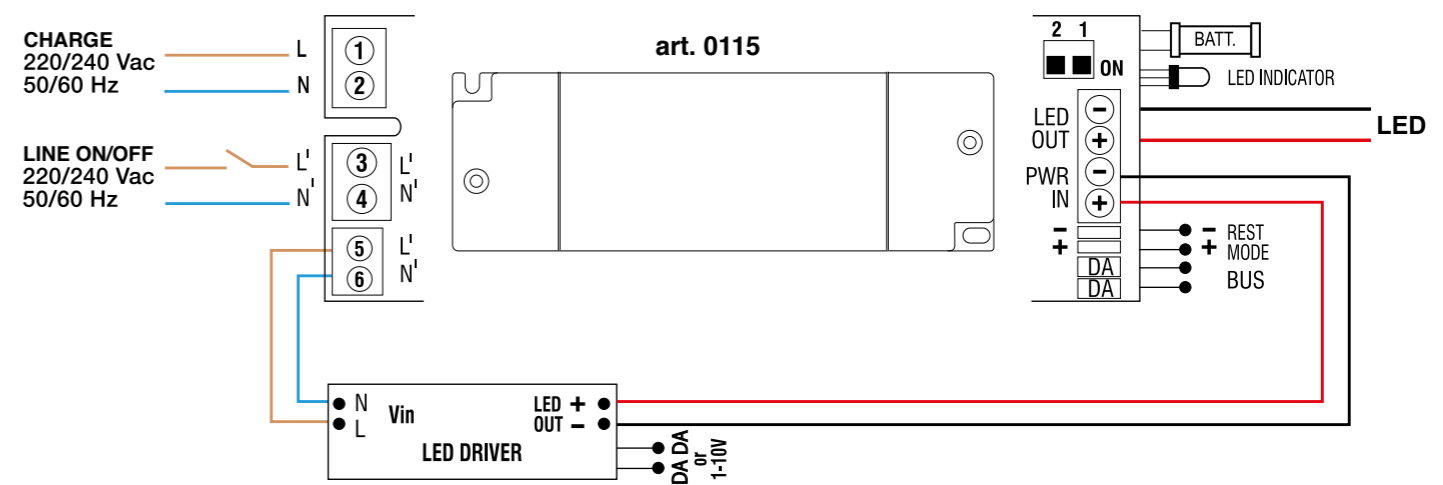

6604 - 6607 - 6608 - 6620 - 6621 - 6622 - 6626 - 6627 - 6628 - 6629 - 6643

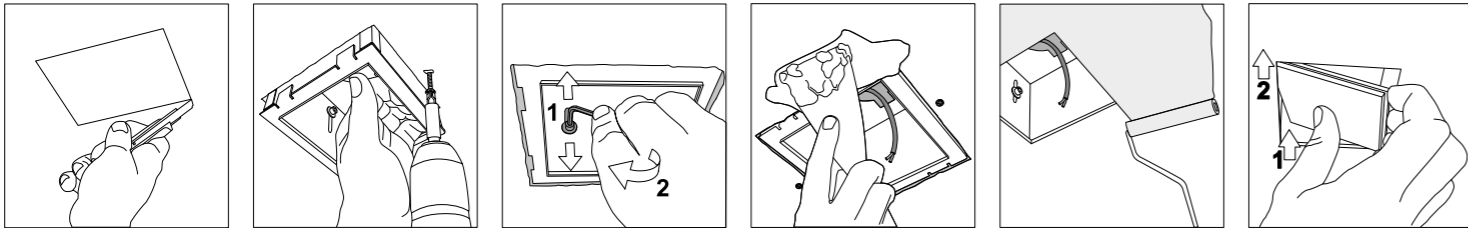

6415 - 6416 - 6609 - 6654 - 6605 - 6623 - 6624 - 6625 - 6654

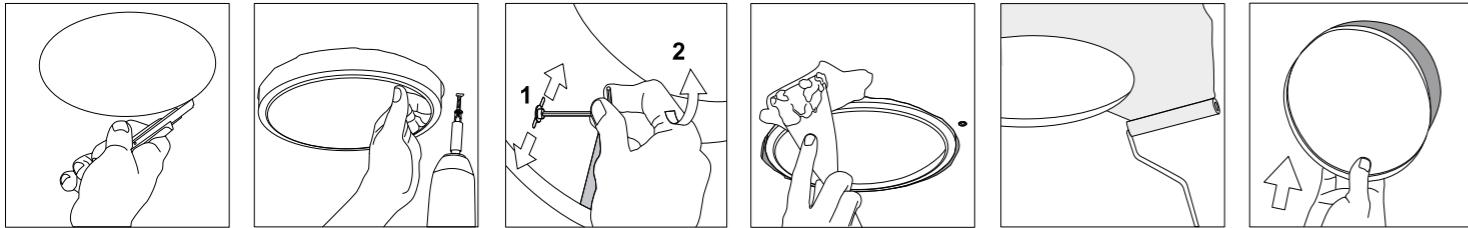

6615 - 6616 - 6617 - 6618 - 6655 - 6656 - 6657 - 6658 - 6660

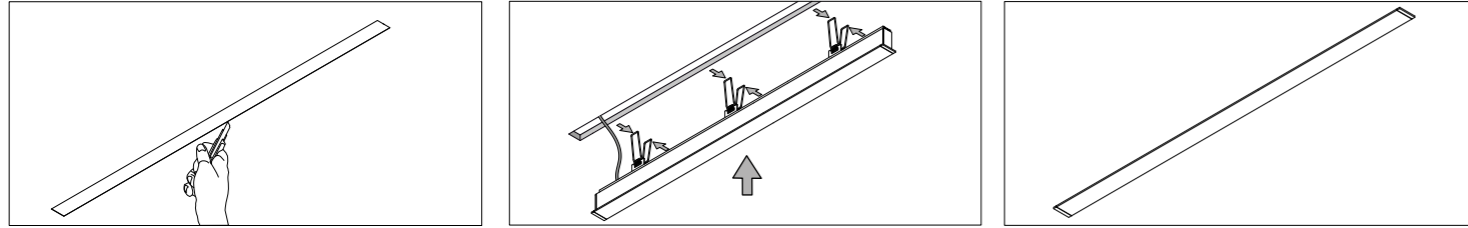

6648 - 6649 - 6650 - 6653 - 6659 - 6662

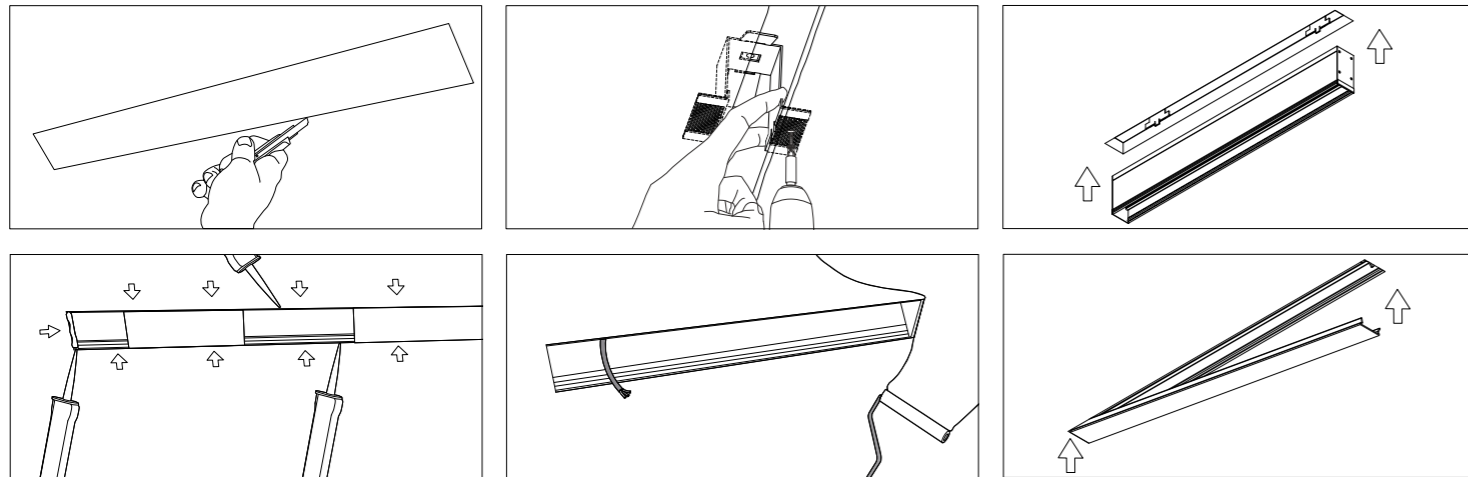

0218+0219 - 0200+0201 - 0200/S

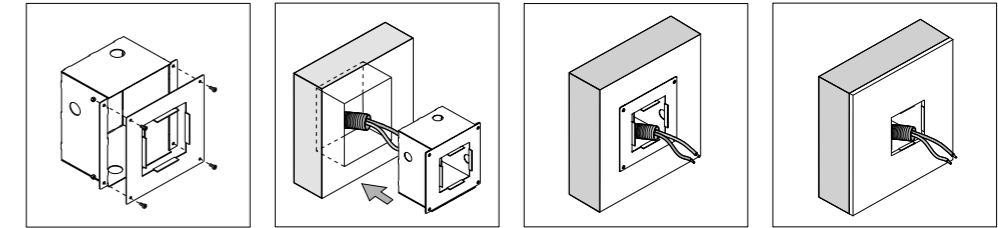

0249

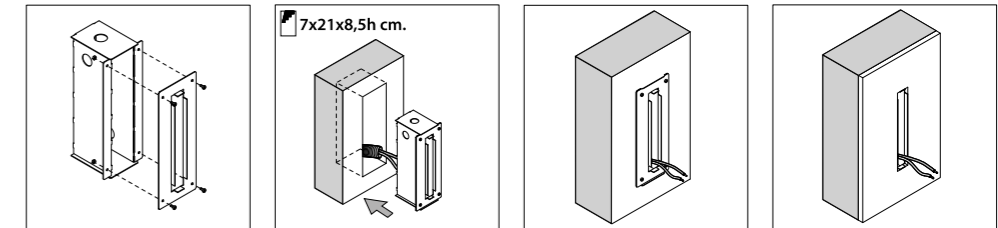

0219

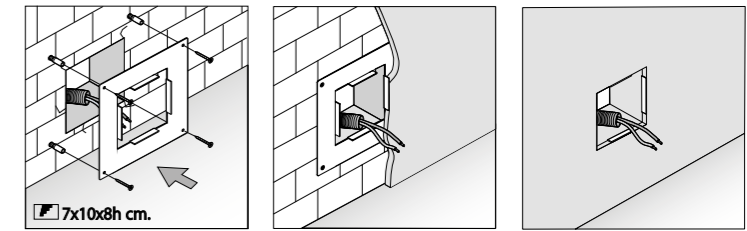

0212 - 0213 - 0214

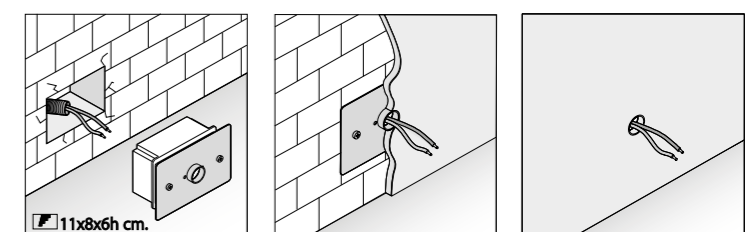

0215 - 0216 - 0217 - 0232

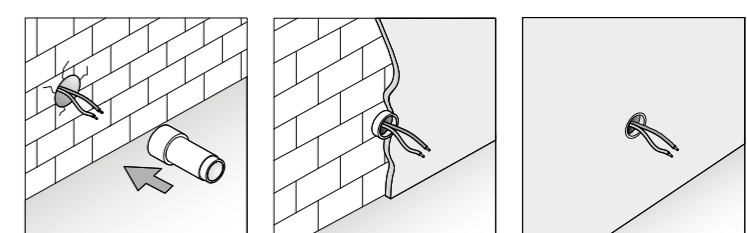

0234

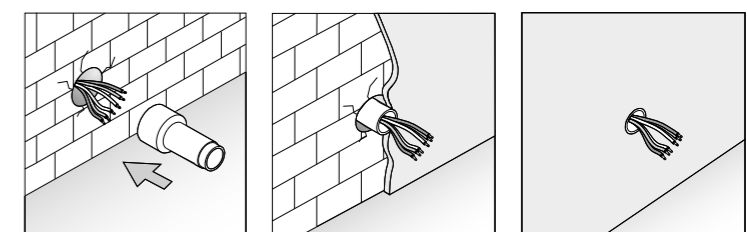

0220 - 0228 - 0250 - 0251

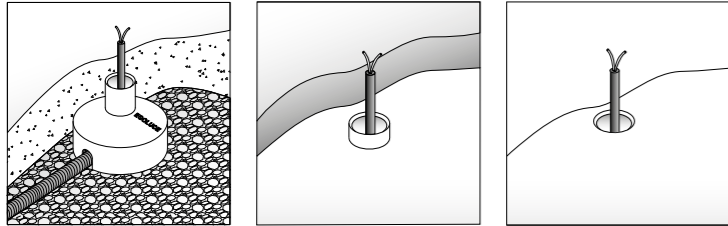

0230 - 0231

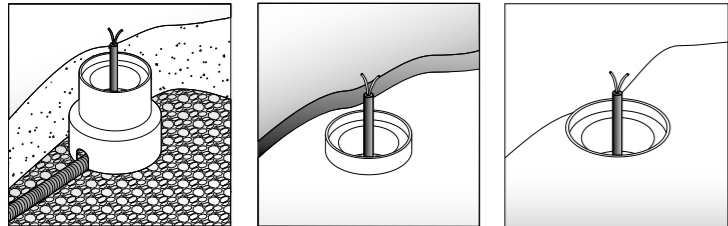

0229

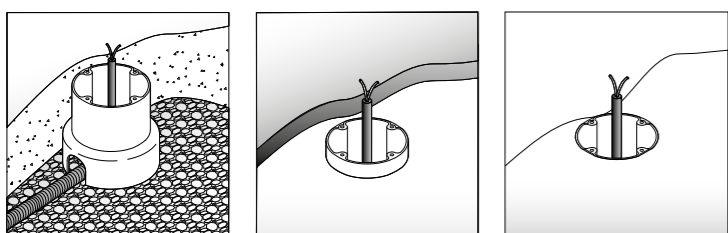

0246

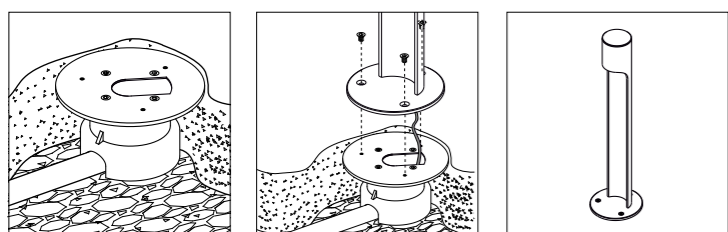

0298 - 0299

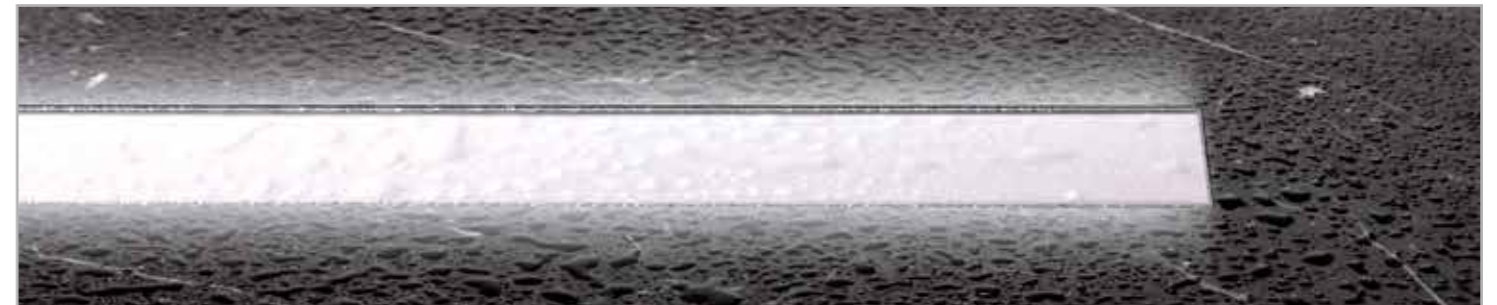
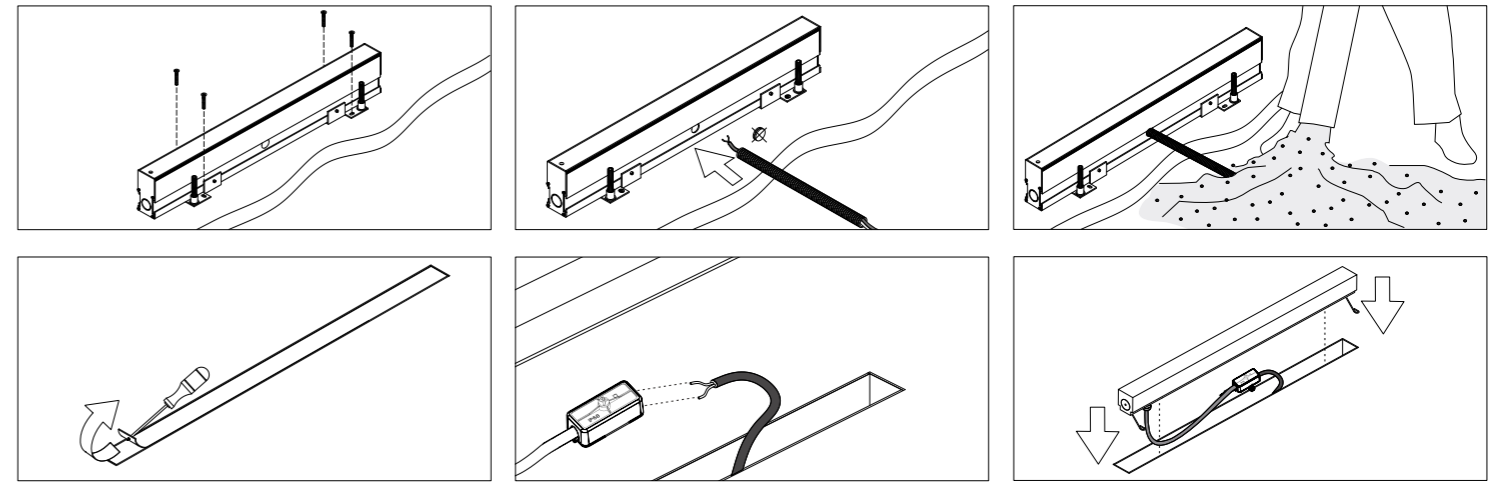

ACCESSORIES

0199

Kit Vetro
Kit diffuser Glass



Edy

0200/S

Kit cassaforma + Plaster
Wall Box + Plaster Kit

Not for 6302



Edy

0200

Cassaforma per calcestruzzo
Wall box for concrete



0201

Piastra per muratura
Plaster Kit



Edy

Edy

0210/100 - 101,8 cm
0210/150 - 151,8 cm
0210/200 - 201,8 cm
0210/300 - 301,8 cm

Cassaforma per calcestruzzo - Wall box for concrete

Linea

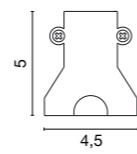

0212 - ø 2

Box + Plaster

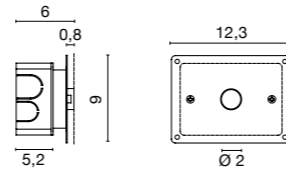

Alcor, Byte, Cruise, Dot, Dot Plus, Sirio, Snorky, Top Mini, Trim, Vega

0213 - ø 3

Box + Plaster

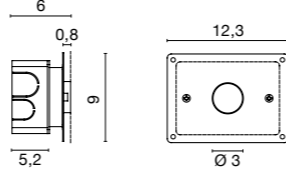

Cerchietto, Fire, Ice, Pix, Top, Snorky Maxi

0214 - ø 3,8

Box + Plaster

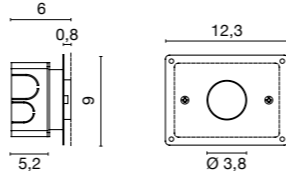

Spoon

0215 - ø 2

Plastic Box

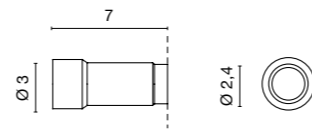

Alcor, Byte, Cruise, Dot, Dot Plus, Sirio, Snorky, Top Mini, Trim, Vega

0216 - ø 3

Plastic box

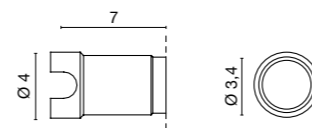

Cerchietto, Ice, Kross, Top, Vista, Fire, Zeppelin, Zeppelin RGB, Zeppelin Plus, Snorky Maxi

0217 - ø 3,8

Plastic box

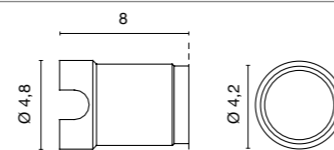

Cerchio, Cerchio RGB, Soft, Spoon

0218

Cassaforma per calcestruzzo
Wallbox for concrete



11 x 11 x 9h cm.



0219

Piastra per muratura.
Plaster kit



Edy Mini

Edy Mini

0220 - ø 3

Kit cassaforma drenante + connettore stagno
Draining junction box + IP67 connector.

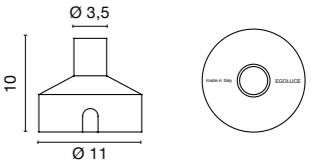

Kross, Zeppelin, Zeppelin Plus, Vista

0228 - ø 3

Cassaforma drenante
Draining junction box

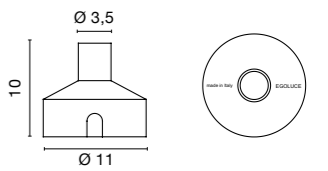

Zeppelin RGB

0229

Kit cassaforma drenante + connettore stagno
Draining junction box + IP67 connector.

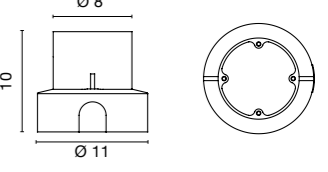

Drive

0230 - ø 6

Kit cassaforma drenante + connettore stagno
Draining junction box + IP67 connector.

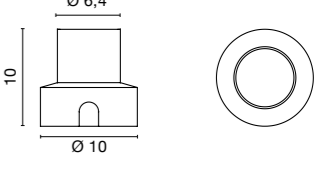

Zeppelin Maxi, Zeppelin Maxi COB

0231

Kit cassaforma drenante + connettore stagno
Draining junction box + IP67 connector.

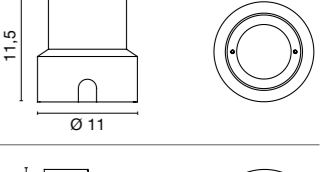

Tris

0232 - ø 6

Plastic box da parete
Wall plastic box

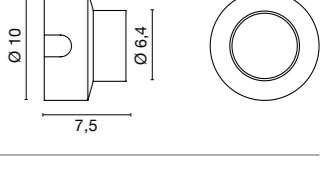

Zeppelin Maxi, Step, Zen Led, Zeppelin Maxi COB

0234

Plastic box RGB

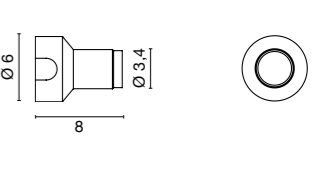

Pix, Pix RGB, Ice RGB, Vega Maxi RGB, Fire RGB, Alcor Maxi RGB

0235

Plastic box da parete
Wall plastic box

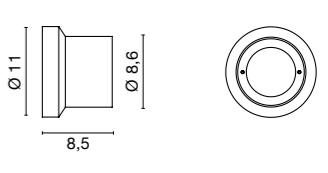

Tris

0243

Connettore stagno per cavi
IP Connector for cables

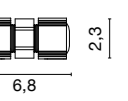

Outdoor

0244/100 - 100 cm

Profilo - Profile

0244/200 - 200 cm

Profilo - Profile

0244/300 - 300 cm

Profilo - Profile

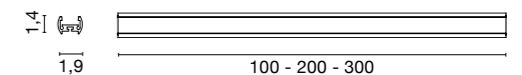

Picchetto per l'installazione
temporanea a terreno
Stake for temporary
installation on field

0247 Vision1



0248 Vision3



ACCESSORIES

0246

Box + Plate

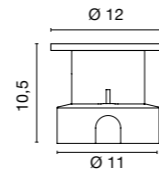

Kepi

0249

Box + Plaster



7x21x8,5 cm.

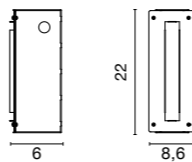

Slot

0250 - ø 3,8

Kit cassaforma drenante + connettore stagno
Draining junction box + IP67 connector.

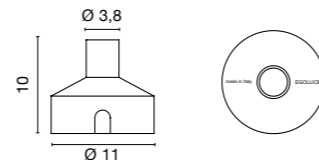

Soft, Cerchio

0251 - ø 3,8

Cassaforma drenante
Draining junction box

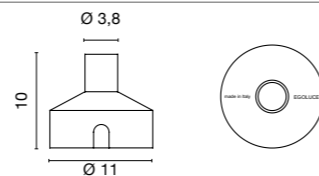

Cerchio RGB

LED DRIVERS

0031/IP

IN: 220 - 240V
OUT: 350 mA - 1-10 Power leds 1W

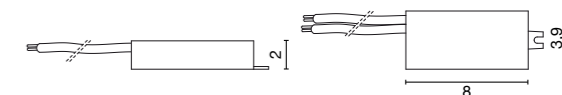

IP67 SELV 4,2 cm.

0033/IP

IN: 220 - 240V
OUT: 24V - 14,4W

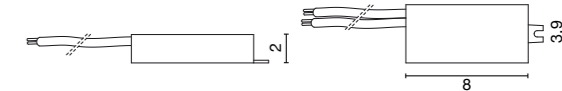

IP67 SELV 4,2 cm.

0034/IP

IN: 220 - 240V
OUT: 24V - 70W

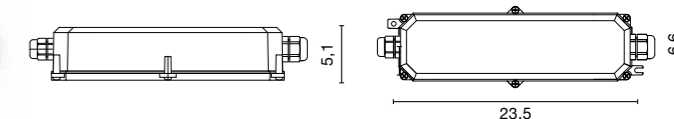

KEMA KEUR IP67 SELV

0035/IP

IN: 220 - 240V
OUT: 24V - 160W

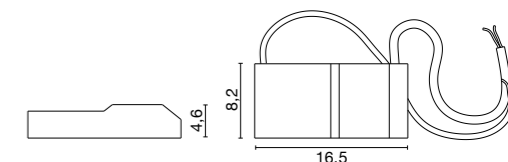

IP65 SELV 9,6 cm.

0036/IP

IN: 220 - 240V
OUT: 12V - 14,4W

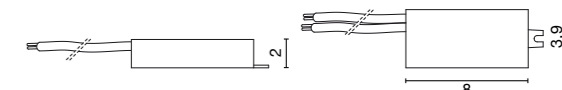

IP67 SELV 4,2 cm.

0125

IN: 100 - 240V
OUT: 350 mA - 1-6 Power leds 1W, 1 0107



KEMA KEUR SELV 4,5 cm.

0125/250

IN: 220 - 240V
OUT: 250 mA - 1 Pinco COB



SELV 4,4 cm.

0126

IN: 110 - 240V
OUT: 700 mA - 1-6 Power leds 3W

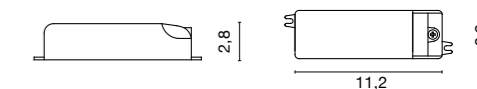

SELV 4,8 cm.

0127

IN: 100 - 240V
OUT: 500 mA - 1-6 Power leds 2W,
1 0108, 1 Dissy

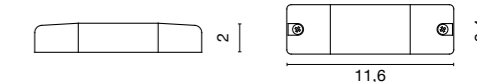

SELV CLASS 2 4 cm.

0128

IN: 100 - 240V
OUT: 350 mA - 1-10 Power leds 1W,
2 0107

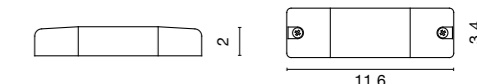

SELV CLASS 2 4 cm.

0130

IN: 220 - 240V
OUT: 8V - 1-40 Lucciole

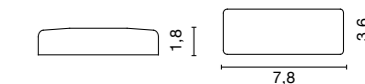

SELV 4,5 cm.

0135

IN: 220 - 240V
OUT: 500mA - 1 Tappo maxi
600mA - 1 Tappo maxi
700mA - 1 Tappo maxi

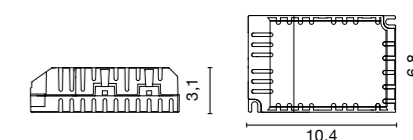

CLASS 2 SELV 7,6 cm.

LED DRIVERS

0143/IP

IN: 220 - 240V
OUT: 500 mA - 1-7 Power Leds 2W

IP67 SELV 4,5 cm.

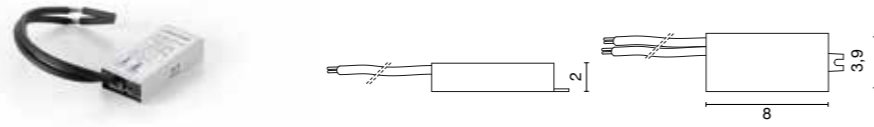

0147/COB

IN: 220 - 240V
OUT: 500 mA - 2 0108, 2 Dissy, 1 Vero mini, 1 Vero

SELV 4,2 cm.

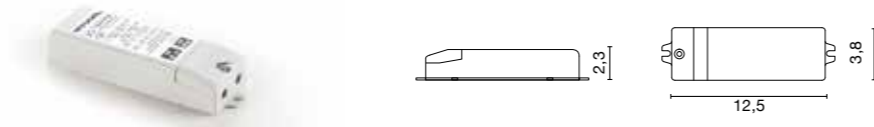

0148/COB

IN: 220 - 240V
OUT: 700 mA - 1 Vero maxi

SELV 4,2 cm.

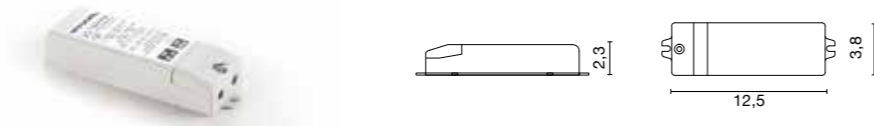

0155

IN: 100 - 240V
OUT: 24V - 13W

KEMA KEUR SELV 3,2 cm.

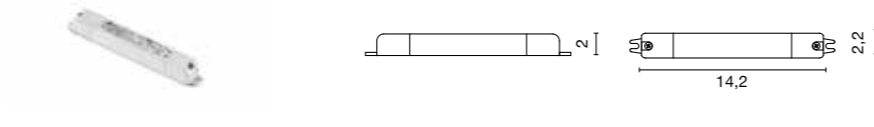

0156

IN: 100 - 240V
OUT: 24V - 25W

SELV 6 cm.

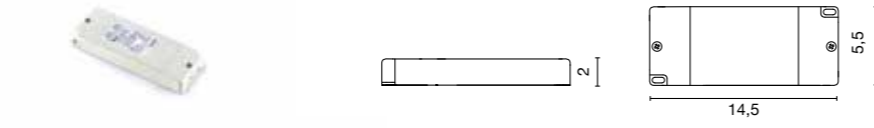

0157

IN: 220 - 240V
OUT: 24V - 70/72W

KEMA KEUR SELV 7 cm.

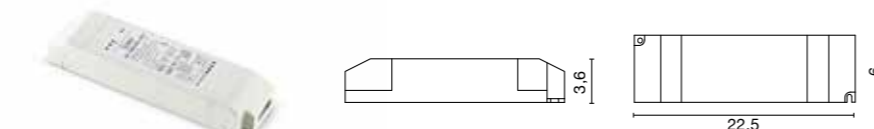

0159

IN: 100 - 240V
OUT: 12V - 25W

SELV 6 cm.

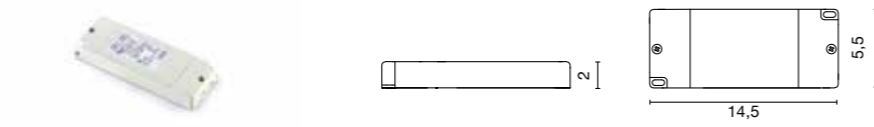

0160

IN: 220 - 240V
OUT: 24V - 50W

KEMA KEUR SELV 7 cm.

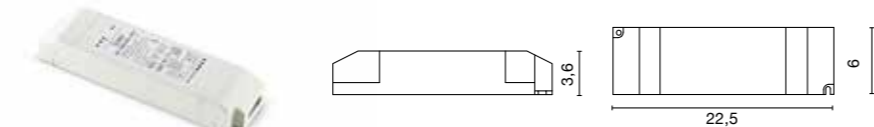

0162

IN: 220 - 240V
OUT: 24V - 150W

KEMA KEUR SELV 8 cm.

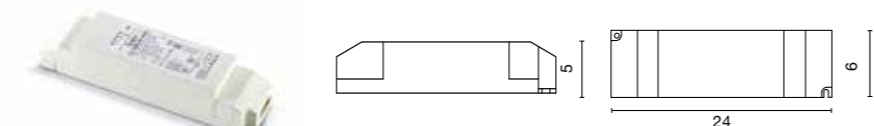

0169

IN: 220 - 240V
OUT: 350mA - 4-12 Power led 1W
500mA - 1 Vero, 1 Vero Mini, 4-12 Power led 2W
700mA - 1 Vero Maxi

SELV 5,4 cm.

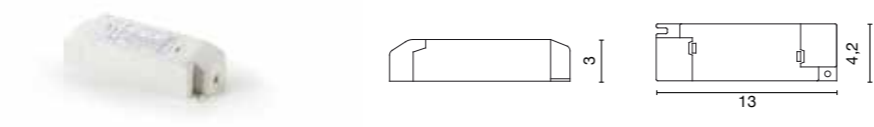

0161/100

IN: 220 - 240V
OUT: 24V - 100W

SELV 8 cm.

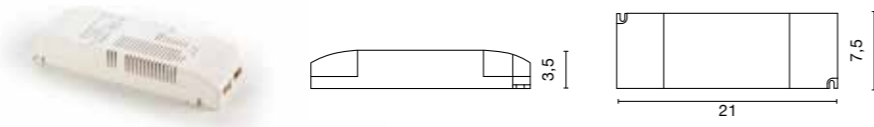

0173

IN: 100 - 240V
OUT: 12V - 50W

KEMA KEUR SELV 7 cm.

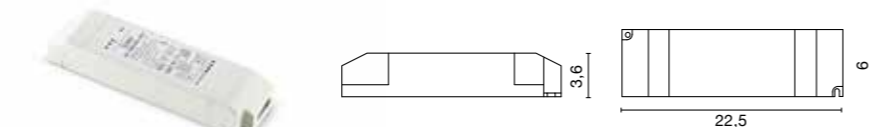

LED DIMMERS

0110/DIM

12/24V 12A

PUSH 1...10 V DALI SELV 5,6 cm.

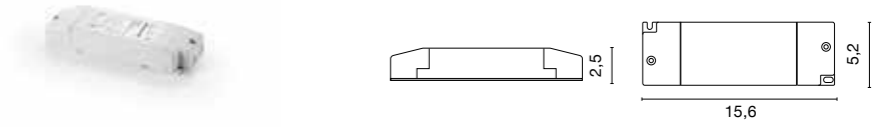

0129

IN: 110 - 240V
OUT: 350 mA - 1-11 power leds, 1-2 COB (art.0107)
500 mA - 1-10 power leds, 1-2 COB (art.0108)
700 mA - 1-9 power leds

PUSH 1...10 V SELV 7,2 cm.

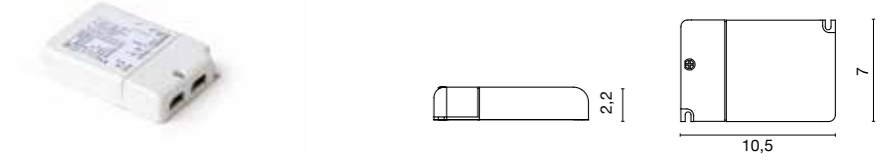

0129/DALI

IN: 110 - 240V
OUT: 350 mA - 1-12 power leds, 1-2 COB (art.0107)
500 mA - 1-12 power leds, 1-2 COB (art.0108)
700 mA - 1-12 leds

DALI SELV 7,2 cm.

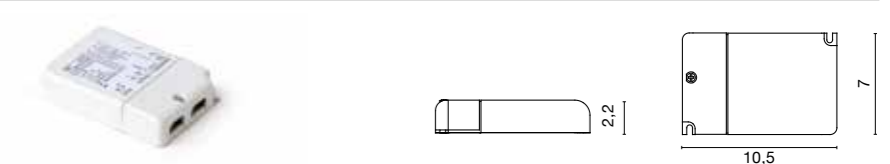

0145

IN: 110 - 240V
OUT: 350 mA - 1- 20 power leds, 1-3 COB (art.0107)
500 mA - 1-19 power leds, 1-3 COB (art.0108)
700 mA - 1-18 power leds

PUSH 1...10 V SELV 8,4 cm.

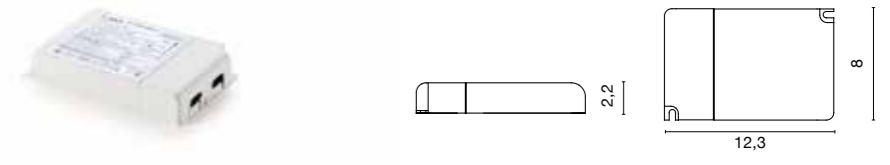

0145/DALI

IN: 110 - 240V
OUT: 350 mA - 1- 20 power leds, 1-3 COB (art.0107)
500 mA - 1-19 power leds, 1-3 COB (art.0108)
700 mA - 1-18 power leds

PUSH 1...10 V DALI SELV 8,4 cm.

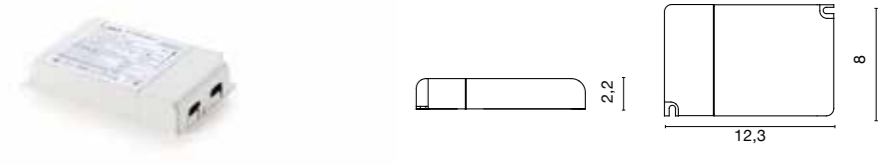

0133

Cavo di sincronizzazione per dimmer Led
Sincronization cable for dimmer Led



0129, 0129 DALI, 0145, 0145 DALI

0717/DIM60

IN: 220 - 240V
OUT: 24V - 60W

PUSH 1...10 V SELV 8,6 cm.

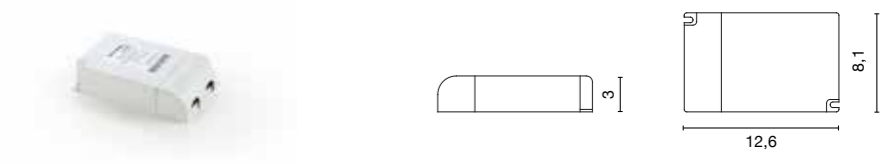

0717/DIM100

IN: 220 - 240V
OUT: 24V - 100W

PUSH 1...10 V DALI 8,2 cm.

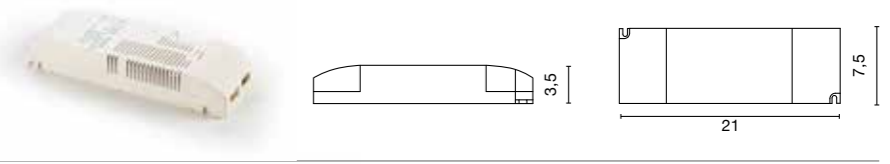

0726/DIM

Dimmer
TAGLIO DI FASE (IGBT-TRIAC)
PHASE CUT-OFF (TRAILING EDGE-LEADING EDGE)
IN: 220 - 240V
OUT: 24V - 20W
350 mA - 1-12 power leds, 1-2 COB (art.0107)
500 mA - 1-12 power leds, 1-2 COB (art.0108)
700 mA - 1- 9 power leds
2 DISSY - 1 VERO MINI - 1VERO - 1 VERO MAXI

PUSH IGBT/TRIAC SELV 5,6 cm.

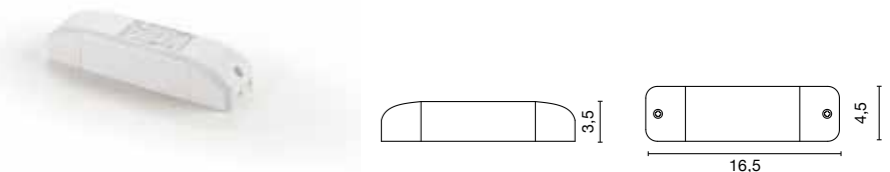

DMX INTERFACE

0729/DMX

Convertitore di segnale DMX - PWM
DMX - PWM Signal converter
IN: 100 - 240V

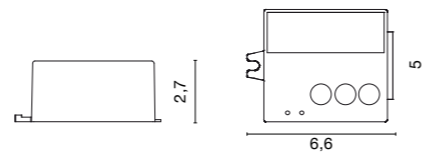

0164, 0167

0166

Cavo di sincronizzazione
Synchronization cable

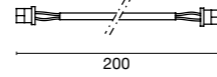

0164, 0167, 0729/DMX

LED EMERGENCY UNIT

0115/EM

Kit Inverter + Battery

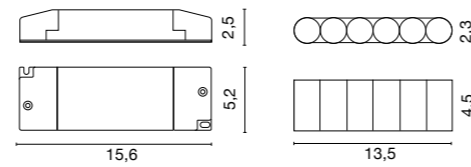

0115/EM/3

Kit Inverter + Battery 3h.

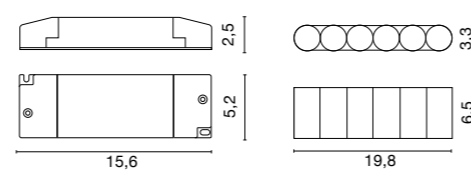

RGB DRIVERS

0167 Driver RGB 22W

IN: 220-240V
OUT: 3x24V

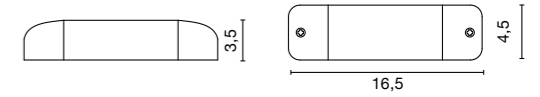

PUSH Remote 5,6 cm.

0164 Driver RGB 120W

IN: 220-240V
OUT: 3x24V

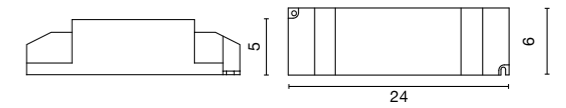

PUSH Remote 8 cm.

0168 Converter

IN: 3x24V
OUT: 3x250 mA 1-5 RGB

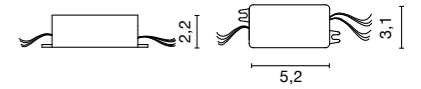

0163 IR Receiver



2,5 cm.

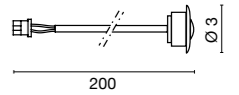

0164, 0167

0165 IR Remote Controller

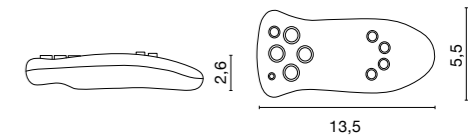

0166

Cavo di sincronizzazione
Synchronization cable

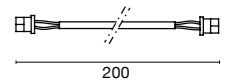

0164, 0167

0152

Kit Lucciola RGB



LED

POWER LED



Source LED cod.	OPTIC degree		lm	LED color
0120	25°	2W 500mA	209lm	4000K
0122	25°	2W 500mA	199lm	3000K

POWER LED



Source LED cod.	OPTIC degree		lm	LED color
0121	25°	3x3W 700mA	846lm	4000K
0123	25°	3x3W 700mA	804lm	3000K

COB LED



Source LED cod.	OPTIC degree		lm	LED color
0107/XW	124 140 160	6,2W 17,8V 350mA	740lm	2700K
0107/WW	124 140 160	6,2W 17,8V 350mA	785lm	3000K
0107/W	124 140 160	6,2W 17,8V 350mA	829lm	4000K
0107/CW	124 140 160	6,2W 17,8V 350mA	850lm	5000K

0108/XW	124 140 160	9,2W 18,4V 500mA	995lm	2700K
0108/WW	124 140 160	9,2W 18,4V 500mA	1056lm	3000K
0108/W	124 140 160	9,2W 18,4V 500mA	1115lm	4000K
0108/CW	124 140 160	9,2W 18,4V 500mA	1160lm	5000K

0108/WW/IP	124 138 158	9,2W 18,4V 500mA	1056lm	3000K
0108/W/IP	124 138 158	9,2W 18,4V 500mA	1115lm	4000K

0092/16	50/60Hz 220-240V	3,5W G9 LED 330lm 3000K
---------	------------------	-------------------------

0094/16	50/60Hz 220-240V	7W GU10 LED 600lm 3000K	
---------	------------------	-------------------------	--

0104/16	50/60Hz 220-240V	7W GU10 LED 530lm 3000K	
Dimmerabile - Dimmable			

0105/16	50/60Hz 220-240V	12W E27 LED 1100lm 3000K
---------	------------------	--------------------------

0105/MINI	50/60Hz 220-240V	6W E14 LED 600lm 3000K
-----------	------------------	------------------------

0105/GLOBO	50/60Hz 220-240V	21W E27 LED 1950lm 3000K
------------	------------------	--------------------------

230V HALO

0072	50W GU10
------	----------

0072/G	75W GU10
--------	----------

0092/20	20W G9 ECO
0092/33	33W G9 ECO
0092/48	48W G9 ECO
0092/60	60W G9 ECO

0074	75W E27 PAR 20
------	----------------

0074	75W E27 PAR 30
------	----------------

HALO 12V

0071	12V 50W GU5,3 Ø 5
------	-------------------

ONLY FOR LED VERSIONS



Dischi reggi lampadina
Dischi in metacrilato per il fissaggio del modulo LED da utilizzare come alternativa alle molle a filo. Disponibili in finitura trasparente (TR) o satinata (ST).

Bulb fixers
Methacrylate disks for fixing LED module to be used instead of the wire springs. Available in clear finish (TR) or satin (ST).

AVAILABLE FOR:

6048



GEKO LED



TAPPO



TAPPO ORIENTABILE



6447



ROTONDO



EXAMPLES:



6330 - Standard



6330 - Con 0183/ST
With 0183/ST



6330 - Con 0183/TR
With 0183/TR

ALPHABETICAL INDEX

CODICE	PRODOTTO	PAG	CODICE	PRODOTTO	PAG
6024	6024	404	4527	FLAN	264
6028	6028	404	4526	FLAN	264
6030	6030	404	6550	FLAN BINARIO	266
6204	6204	402	6551	FLAN BINARIO	266
6239	6239	402	6165	FRIDA	403
6240	6240	402	6553	GALILEO	252
6048	6048 12V	361	6555	GALILEO MAXI COB	254
6048	6048 LED	360	6249	GAMMA	403
6056	6056 230V	361	6460	GEKO 12V	395
6447	6447 12V	392	6290	GEKO 230V	395
6447	6447 LED	392	6460	GEKO LED	394
6455	6455 230V	393	4514	GEO BIEMISSIONE	162
6360	ALCOR	290	4513	GEO MONOEMISSIONE	162
6379	ALCOR MAXI RGB	292	6608	GHOST	110
5561	ALEA LED	60	6608	GHOST DIM	110
5511	ASTRA	240	6608	GHOST DIM DALI	110
5552	ASTRA 120	242	6607	GHOST MAXI	114
5551	ASTRA IP	241	6607	GHOST MAXI DIM	115
9000	BIBOX	272	6607	GHOST MAXI DIM DALI	115
9005	BIBOX FLUJO 2x24W	276	6604	GHOST MINI	108
9006	BIBOX FLUJO 2x39W	276	6604	GHOST MINI DIM	108
9002	BIBOX SPOT	274	6604	GHOST MINI DIM DALI	108
6357	BYTE QUADRO	310	6643	GHOST UP	111
6356	BYTE TONDO	310	6643	GHOST UP DIM	111
6620	CASPER 12V	105	6643	GHOST UP DIM DALI	111
6621	CASPER 230V	105	6629	GHOST UP MINI	109
6622	CASPER LED	104	6629	GHOST UP MINI DIM	109
6391	CERCHIETTO	320	6629	GHOST UP MINI DIM DALI	109
6389	CERCHIO	190	6355	ICE QUADRO	302
6390	CERCHIO RGB	192	6377	ICE RGB	304
7230	COLIBRI KIT LED	260	6354	ICE TONDO	302
6533	COLIBRI' SMALL LED	258	6661	INTO	226
6534	COLIBRI' SMALL LED BINARIO	258	5538	JAZZ	154
5534	COMETA IP 20 HIGH 72W	244	3502	KEPI	150
5516	COMETA IP 20 LOW 30W	245	6361	KROSS	196
6382	CRUISE	322	1540	LANCIA SOSPENSIONE	210
6493	DELTA LED	352	6615	LINEA	76
6493	DELTA LED DIM	352	6616	LINEA	76
6493	DELTA LED DIM DALI	352	6655	LINEA MAXI	72
6492	DELTA MINI LED	350	6656	LINEA MAXI	72
6492	DELTA MINI LED DIM	350	6657	LINEA MAXI RGB	80
6492	DELTA MINI LED DIM DALI	350	6658	LINEA MAXI RGB	80
6409	DISSY QUADRO	340	6617	LINEA RGB	80
6410	DISSY TONDO	368	6618	LINEA RGB	80
6316	DOT PLUS	286	6372	LUCCIOLA	282
6321	DOT QUADRO	284	6353	LUCCIOLA RGB	283
6320	DOT TONDO	284	4523	MAGIKA	232
6366	DRIVE	200	4522	MAGIKA	232
5520	DRUM	160	4520	MARGO	220
6430	EASY QUADRO 12V	339	6609	MIRAGE	127
6432	EASY QUADRO 230V	339	6609	MIRAGE DIM	127
6431	EASY QUADRO LED	338	6609	MIRAGE DIM DALI	127
6440	EASY TONDO 12V	367	6654	MIRAGE MAXI	130
6442	EASY TONDO 230V	367	6654	MIRAGE MAXI DIM	131
6441	EASY TONDO LED	366	6654	MIRAGE MAXI DIM DALI	131
6300	EDY 12V	347	6605	MIRAGE MINI	126
6301	EDY 45° 12V	347	6605	MIRAGE MINI DIM	126
6302	EDY 230V	347	6605	MIRAGE MINI DIM DALI	126
6303	EDY 45° 230V	347	6265	MODUS	362
6305	EDY LED	346	6398	MODUS LED	362
6298	EDY MINI	344	4582	MOONLIGHT	62
6299	EDY MINI 45°	344	4583	MOONLIGHT	62
6263	EOS PIU'	403	4562	NEWTON	246
4521	EXTRA PLAFONIERA	208	6139	OKKIO	398
1560	EXTRA SOSPENSIONE	206	6324	OKKIO LED	398
6340	FIRE	298	6648	PHANTOM MAXI SISTEMA	90
6341	FIRE RGB	300	6659	PHANTOM MAXI SISTEMA DIM	91

ALPHABETICAL INDEX

CODICE	PRODOTTO	PAG	CODICE	PRODOTTO	PAG
6662	PHANTOM MAXI SISTEMA DIM DALI	91	6426	VERO MINI QUADRO	356
6663	PHANTOM MAXI SISTEMA PLUS	92	6433	VERO MINI TONDO	386
6664	PHANTOM MAXI SISTEMA PLUS DIM	93	6427	VERO QUADRO	356
6665	PHANTOM MAXI SISTEMA PLUS DIM DALI	93	6429	VERO QUADRO ORIENTABILE	358
6650	PHANTOM SISTEMA	84	6434	VERO TONDO	386
6649	PHANTOM SISTEMA DIM	85	6436	VERO TONDO ORIENTABILE	388
6653	PHANTOM SISTEMA DIM DALI	85	4510	VISION 1	168
6352	PINCO COB	396	4554	VISION 1 RGB	169
6323	PIX QUADRO	312	4511	VISION 3	170
6375	PIX RGB	314	4555	VISION 3 COB	170
6322	PIX TONDO	312	6362	VISTA	198
4515	PLANA	216	4536	WANDA	144
6626	QUADRATO 12V	101	4537	WANDA	144
6627	QUADRATO 230V	101	4538	WANDA RGB	147
6628	QUADRATO LED	100	4539	WANDA RGB	147
4578	RAIL PARETE	56	6251	ZEN	400
4579	RAIL PARETE	56	6365	ZEN LED	400
6660	RAIL SISTEMA INCASSO	42	6394	ZEPPELIN 25 PLUS QUADRO	178
4580	RAIL SISTEMA PARETE	34	6384	ZEPPELIN 25 PLUS TONDO	178
4581	RAIL SISTEMA PARETE	34	6411	ZEPPELIN ORIENTABILE	184
5542	RAIL SISTEMA SOFFITTO PARETE	18	6349	ZEPPELIN QUADRO	174
5543	RAIL SISTEMA SOFFITTO PARETE	18	6395	ZEPPELIN RGB QUADRO	176
1543	RAIL SISTEMA SOSPENSIONE	26	6348	ZEPPELIN TONDO	174
1544	RAIL SISTEMA SOSPENSIONE	26	6376	ZEPPELIN RGB TONDO	176
5540	RAIL SOFFITTO PARETE	58	6397	ZEPPELIN MAXI COB	180
5541	RAIL SOFFITTO PARETE	58	6383	ZEPPELIN MAXI QUADRO	182
1541	RAIL SOSPENSIONE	50	6368	ZEPPELIN MAXI TONDO	182
1542	RAIL SOSPENSIONE	50	6623	ZERO 12V	123
1545	RAIL SOSPENSIONE BIEMISSIONE	54	6624	ZERO 230V	123
5539	ROC	156	6625	ZERO LED	122
6415	ROTONDO 12V	119	6137	ZIC	396
6416	ROTONDO 230V	119			
6415	ROTONDO LED	118			
6359	SIRIO	288			
6381	SLOT	332			
6373	SNORKY	316			
6313	SNORKY MAXI	318			
6388	SOFT	188			
6417	SPOOK	136			
6418	SPOOK	136			
6419	SPOOK	136			
6351	SPOON QUADRO	330			
6350	SPOON TONDO	328			
6369	STEP QUADRO	194			
6387	STEP TONDO	194			
6330	TAPPO 12V	376			
6329	TAPPO 230V	376			
6330	TAPPO LED	374			
6331	TAPPO MAXI LED	379			
6399	TAPPO MAXI LED	378			
6327	TAPPO MINI 12V	372			
6327	TAPPO MINI LED	372			
6318	TAPPO ORIENTABILE 12V	381			
6319	TAPPO ORIENTABILE 230V	381			
6318	TAPPO ORIENTABILE LED	380			
6363	TOP	306			
6364	TOP MINI	308			
6337	TRIM QUADRO BIEMISSIONE	326			
6339	TRIM QUADRO MONOEMISSIONE	324			
6336	TRIM TONDO BIEMISSIONE	326			
6338	TRIM TONDO MONOEMISSIONE	324			
6371	TRIS	186			
6358	VEGA	294			
6378	VEGA MAXI RGB	296			
6437	VENTITRE'	390			
6428	VERO MAXI QUADRO	356			
6435	VERO MAXI TONDO	386			

NUMERICAL INDEX

CODICE	PRODOTTO	PAG
1540	LANCIA SOSPENSIONE	210
1541	RAIL SOSPENSIONE	50
1542	RAIL SOSPENSIONE	50
1543	RAIL SISTEMA SOSPENSIONE	26
1544	RAIL SISTEMA SOSPENSIONE	26
1545	RAIL SOSPENSIONE BIEMISSIONE	54
1560	EXTRA SOSPENSIONE	206
3502	KEPI	150
4510	VISION 1	168
4511	VISION 3	170
4513	GEO MONOEMISSIONE	162
4514	GEO BIEMISSIONE	162
4515	PLANA	216
4520	MARGO	220
4521	EXTRA PLAFONIERA	208
4522	MAGIKA	232
4523	MAGIKA	232
4526	FLAN	264
4527	FLAN	264
4536	WANDA	144
4537	WANDA	144
4538	WANDA RGB	147
4539	WANDA RGB	147
4554	VISION 1 RGB	169
4555	VISION 3 COB	170
4562	NEWTON	246
4578	RAIL PARETE	56
4579	RAIL PARETE	56
4580	RAIL SISTEMA PARETE	34
4581	RAIL SISTEMA PARETE	34
4582	MOONLIGHT	62
4583	MOONLIGHT	62
5511	ASTRA	240
5516	COMETA IP 20 LOW 30W	245
5520	DRUM	160
5534	COMETA IP 20 HIGH 72W	244
5538	JAZZ	154
5539	ROC	156
5540	RAIL SOFFITTO PARETE	58
5541	RAIL SOFFITTO PARETE	58
5542	RAIL SISTEMA SOFFITTO PARETE	18
5543	RAIL SISTEMA SOFFITTO PARETE	18
5551	ASTRA IP	241
5552	ASTRA 120	242
5561	ALEA LED	60
6024	6024	404
6028	6028	404
6030	6030	404
6048	6048 LED	360
6048	6048 12V.	361
6056	6056 230V.	361
6137	ZIC	396
6139	OKKIO	398
6165	FRIDA	403
6204	6204	402
6239	6239	402
6240	6240	402
6249	GAMMA	403
6251	ZEN	400
6263	EOS PIU'	403
6265	MODUS	362
6290	GEKO 230V.	395
6298	EDY MINI	344
6299	EDY MINI 45°	344
6300	EDY 12V.	347
6301	EDY 12V. 45°	347
6302	EDY 230V.	347

CODICE	PRODOTTO	PAG
6303	EDY 230V. 45°	347
6305	EDY LED	346
6313	SNORKY MAXI	318
6316	DOT PLUS	286
6318	TAPPO ORIENTABILE 12V.	381
6318	TAPPO ORIENTABILE LED	380
6319	TAPPO ORIENTABILE 230V.	381
6320	DOT TONDO	284
6321	DOT QUADRO	284
6322	PIX TONDO	312
6323	PIX QUADRO	312
6324	OKKIO LED	398
6327	TAPPO MINI 12V.	372
6327	TAPPO MINI LED	372
6329	TAPPO 230V.	376
6330	TAPPO 12V.	376
6330	TAPPO LED	374
6331	TAPPO MAXI LED	379
6336	TRIM TONDO BIEMISSIONE	326
6337	TRIM QUADRO BIEMISSIONE	326
6338	TRIM TONDO MONOEMISSIONE	324
6339	TRIM QUADRO MONOEMISSIONE	324
6340	FIRE	298
6341	FIRE RGB	300
6348	ZEPPELIN TONDO	174
6349	ZEPPELIN QUADRO	174
6350	SPOON TONDO	328
6351	SPOON QUADRO	330
6352	PINCO COB	396
6353	LUCCIOLA RGB	283
6354	ICE TONDO	302
6355	ICE QUADRO	302
6356	BYTE TONDO	310
6357	BYTE QUADRO	310
6358	VEGA	294
6359	SIRIO	288
6360	ALCOR	290
6361	KROSS	196
6362	VISTA	198
6363	TOP	306
6364	TOP MINI	308
6365	ZEN LED	400
6366	DRIVE	200
6368	ZEPPELLIN MAXI TONDO	182
6369	STEP QUADRO	194
6371	TRIS	186
6372	LUCCIOLA	282
6373	SNORKY	316
6375	PIX RGB	314
6376	ZEPPELIN TONDO RGB	176
6377	ICE RGB	304
6378	VEGA MAXI RGB	296
6379	ALCOR MAXI RGB	292
6381	SLOT	332
6382	CRUISE	322
6383	ZEPPELLIN MAXI QUADRO	182
6384	ZEPPELIN 25 PLUS TONDO	178
6387	STEP TONDO	194
6388	SOFT	188
6389	CERCHIO	190
6390	CERCHIO RGB	192
6391	CERCHIETTO	320
6394	ZEPPELIN 25 PLUS QUADRO	178
6395	ZEPPELIN QUADRO RGB	176
6397	ZEPPELLIN MAXI COB	180
6398	MODUS LED	362
6399	TAPPO MAXI LED	378

CODICE	PRODOTTO	PAG
6409	DISSY QUADRO	340
6410	DISSY TONDO	368
6411	ZEPPELIN ORIENTABILE	184
6415	ROTONDO 12V.	119
6415	ROTONDO LED	118
6416	ROTONDO 230V.	119
6417	SPOOK	136
6418	SPOOK	136
6419	SPOOK	136
6426	VERO MINI QUADRO	356
6427	VERO QUADRO	356
6428	VERO MAXI QUADRO	356
6429	VERO QUADRO ORIENTABILE	358
6430	EASY QUADRO 12V.	339
6431	EASY QUADRO LED	338
6432	EASY QUADRO 230V.	339
6433	VERO MINI TONDO	386
6434	VERO TONDO	386
6435	VERO MAXI TONDO	386
6436	VERO TONDO ORIENTABILE	388
6437	VENTITRE'	390
6440	EASY TONDO 12V.	367
6441	EASY TONDO LED	366
6442	EASY TONDO 230V.	367
6447	6447 12V.	392
6447	6447 LED	392
6455	6455 230V.	393
6460	GEKO 12V.	395
6460	GEKO LED	394
6492	DELTA MINI LED	350
6492	DELTA MINI LED DIM	350
6492	DELTA MINI LED DIM DALI	350
6493	DELTA LED	352
6493	DELTA LED DIM	352
6493	DELTA LED DIM DALI	352
6533	COLIBRI' SMALL LED	258
6534	COLIBRI' SMALL LED BINARIO	258
6550	FLAN BINARIO	266
6551	FLAN BINARIO	266
6553	GALILEO	252
6555	GALILEO MAXI COB	254
6604	GHOST MINI	108
6604	GHOST MINI DIM	108
6604	GHOST MINI DIM DALI	108
6605	MIRAGE MINI	126
6605	MIRAGE MINI DIM	126
6605	MIRAGE MINI DIM DALI	126
6607	GHOST MAXI	114
6607	GHOST MAXI DIM	115
6607	GHOST MAXI DIM DALI	115
6608	GHOST	110
6608	GHOST DIM	110
6608	GHOST DIM DALI	110
6609	MIRAGE	127
6609	MIRAGE DIM	127
6609	MIRAGE DIM DALI	127
6615	LINEA	76
6616	LINEA	76
6617	LINEA RGB	80
6618	LINEA RGB	80
6620	CASPER 12V.	105
6621	CASPER 230V.	105
6622	CASPER LED	104
6623	ZERO 12V.	123
6624	ZERO 230V.	123
6625	ZERO LED	122
6626	QUADRATO 12V.	101

NUMERICAL INDEX

CODICE	PRODOTTO	PAG
6627	QUADRATO 230V.	101
6628	QUADRATO LED	100
6629	GHOST UP MINI	109
6629	GHOST UP MINI DIM	109
6629	GHOST UP MINI DIM DALI	109
6643	GHOST UP	111
6643	GHOST UP DIM	111
6643	GHOST UP DIM DALI	111
6648	PHANTOM MAXI SISTEMA	90
6649	PHANTOM SISTEMA DIM	85
6650	PHANTOM SISTEMA	84
6653	PHANTOM SISTEMA DIM DALI	85
6654	MIRAGE MAXI	130
6654	MIRAGE MAXI DIM	131
6654	MIRAGE MAXI DIM DALI	131
6655	LINEA MAXI	72
6656	LINEA MAXI	72
6657	LINEA MAXI RGB	80
6658	LINEA MAXI RGB	80
6659	PHANTOM MAXI SISTEMA DIM	91
6660	RAIL SISTEMA INCASSO	42
6661	INTO	226
6662	PHANTOM MAXI SISTEMA DIM DALI	91
6663	PHANTOM MAXI SISTEMA PLUS	92
6664	PHANTOM MAXI SISTEMA PLUS DIM	93
6665	PHANTOM MAXI SISTEMA PLUS DIM DALI	93
7230	COLIBRI' KIT LED	260
9000	BIBOX	272
9002	BIBOX SPOT	274
9005	BIBOX FLUO 2x24W	276
9006	BIBOX FLUO 2x39W	276

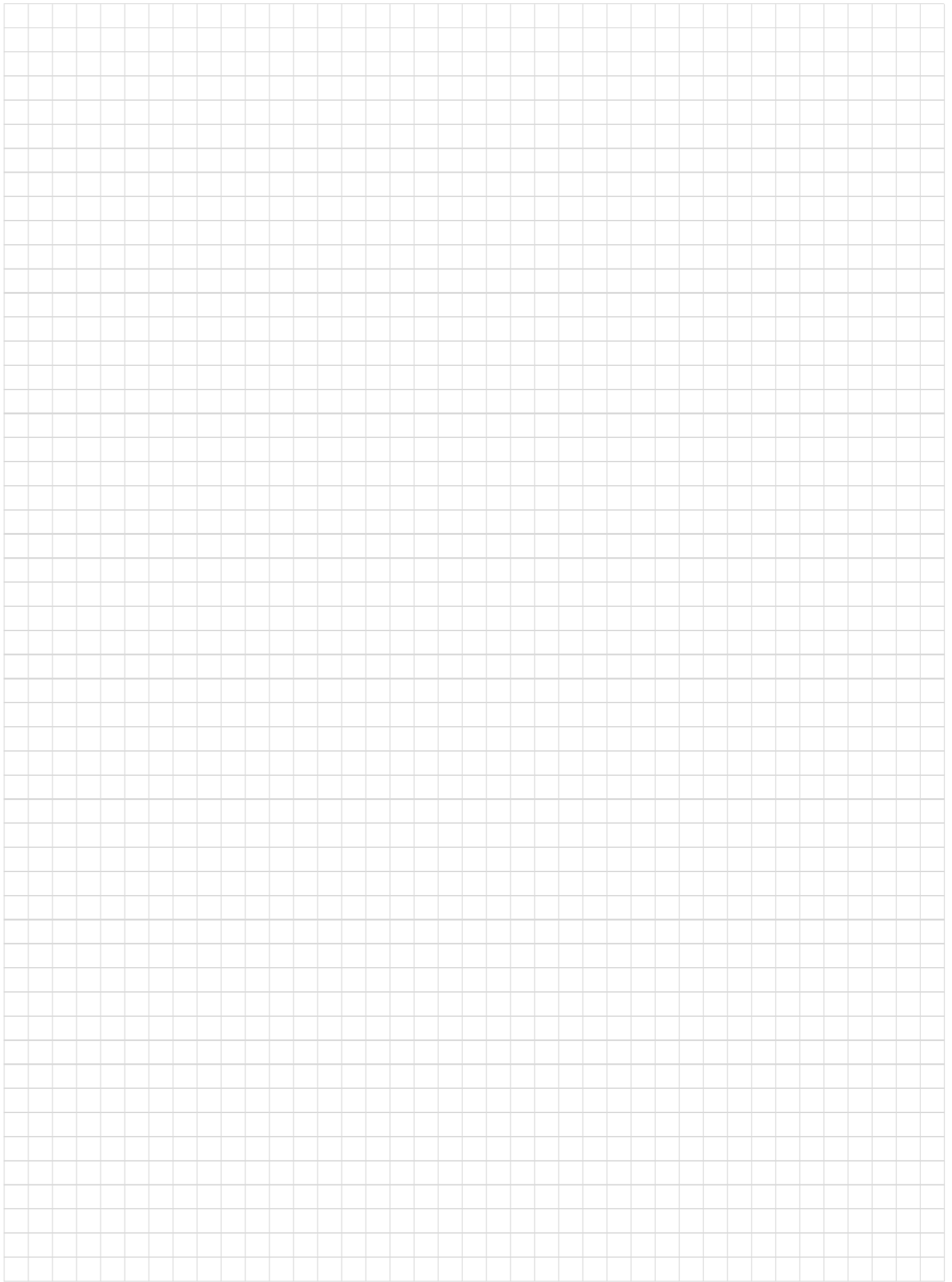
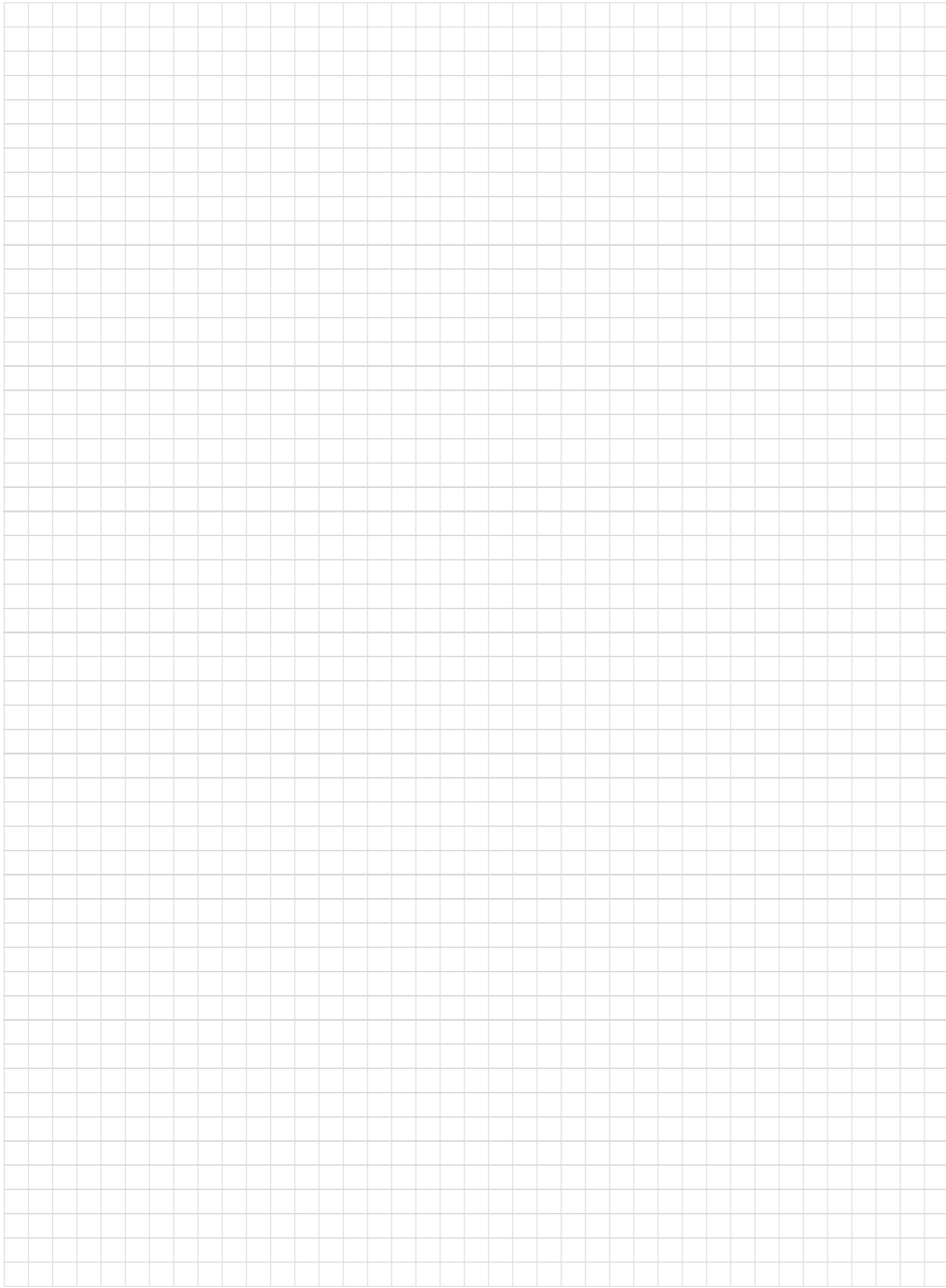



I nostri prodotti sono costruiti in conformità alle norme europee CEI-EN 60598 e, come tali, recano la marcatura CE.

Our fittings are manufactured in conformity with the european standard CEI-EN 60598 and, consequently, get the mark CE.

Nos appareils sont fabriqués en conformité aux règles européennes CEI-EN 60598 et, par conséquence, fournis avec marque CE.

Unsere Produkte werden gemäss europäischer Norm CEI-EN 60598 hergestellt und sind als solche mit dem CE-Zeichen gekennzeichnet.

Nuestros productos son fabricados de conformidad con las normas europeas UNE EN 60598 y, como tal, lleva la marca CE.

Наши изделия изготовлены в соответствии с европейскими нормами CEI-EN 60598 и поэтому отмечены знаком CE.

Egoluce s.r.l. si riserva la facoltà di modificare, in qualsiasi momento e senza preavviso, le caratteristiche tecniche dei modelli illustrati nel presente catalogo.

I colori si intendono indicativi.

Egoluce s.r.l. reserves the right to change, at any time and without prior warning, the technical specification of any product illustrated in this catalogue.

Colours are simply indicative of the real nuance.

Egoluce s.r.l. se réserve le droit de modifier, à n'importe quel moment et sans préavis, les caractéristiques techniques des éléments illustrés dans ce catalogue.

Les couleurs sont simplement a titre indicatif.

Egoluce s.r.l. behält sich vor, jederzeit und fristlos die in beiliegendem Katalog erläuterten technischen Daten zu ändern. Die Farben sind nicht genau wirklichkeitsgetreu.

Egoluce s.r.l. Nos reservamos el derecho de cambiar, en cualquier momento y sin previo aviso de las especificaciones de los productos mostrados en este catálogo.

Los colores son aproximados.

Фабрика Egoluce s.r.l. сохраняет за собой право в любое время и без предварительного уведомления менять технические спецификации любого изделия в этом каталоге.



MADE IN ITALY

EGOLUCE s.r.l. Via I. Newton, 12 - 20016 Pero - Milano - Italy
Tel. +39 02339586.1 - Italia fax +39 023535112 - Int. fax +39 0233911087
E-mail: info@egoluce.com - Int. E-mail: infoworld@egoluce.com

www.egoluce.com