





## A history of light, glass, metal

1950. Italy. Venice. The town of Marcon and the island of Murano are just a few kilometres apart. Angelo Tosetto goes through those few kilometres almost every day from his workshop of artistic chandeliers to the shops of Murano glass masters to steal the secrets of their glass, hand blown in their furnaces.

It's a journey of pure passion, artistic affinities, where light meets matter, glass joins metal – brass, aluminium, steel – and tradition welcomes the future. The beginning of a great story: Studio Italia Design's story.

## From Italy to the world over, a constant evolution.

This is the main path of "made in Italy", chosen and followed by three generations, experimenting each year with new processing techniques, technologies, designs, precious materials and a series of exclusive collaborations to create unique and ingenious luminaires: by form, content, aesthetics and functionality.

It's the path of success, that from Venice leads Studio Italia Design to shift attention to foreign markets, more than 90 countries the world over: to become one of Italian lighting's most internationally developed brands.

## Make room for creativity. In each and every form.

Every path has its limits and to overcome them you need eyes, sensibility, skills and different emotions to decipher an ever changing world. For this reason Studio Italia Design chooses to partner with famous designers, researchers and engineers from a variety of nationalities and backgrounds. A selected group of creative people that together with the firm reinterprets the objects as true interior pieces where the light source plays freely with volumes, reflections, transparencies, lines and all the shades of the materials. Infinite new collections joined together by a common thread of manufacturing excellence.

## Lighting every need in modern living.

The path of innovation also leads to extreme customisation: an answer to the needs that come with new lifestyles thanks to inventive new products custom-made for a variety of different interiors and tailored solutions developed with the leaders in contemporary architecture.

Another new frontier travelled by Studio Italia Design on the path of experience: merging different materials, classicism and avant-garde, craftsmanship and technology. A look at the path where it all began and the excitement in the next step.

THE  
LIGHTING  
MAKERS  
2017

## Una storia di luce, vetro, metallo.

1950. Italia. Venezia. Il paese di Marcon e l'isola di Murano distano pochi chilometri. E sono quelli che Angelo Tosetto percorre quasi ogni giorno dalla sua bottega artigiana di lampadari artistici ai laboratori dei maestri vetrai muranesi, per carpire tutti i segreti del vetro soffiato a bocca nelle fornaci.

È un viaggio di pura passione, affinità artistiche, dove la luce incontra la materia, il vetro si unisce al metallo - l'ottone, l'alluminio, l'acciaio - e la tradizione sorride al futuro. L'inizio di una grande storia: quella di Studio Italia Design.

## Dall'Italia al mondo, evoluzione continua.

Questa è la strada maestra del made in Italy, quella che tre generazioni scelgono di seguire sperimentando ogni anno nuove tecniche di lavorazione, tecnologie, linee, materiali pregiati, e una serie di collaborazioni esclusive nella creazione di lampade uniche e innovative: per forma e contenuto, estetica e funzionalità.

È la via del successo, che da Venezia porta Studio Italia Design ad accendere l'interruttore sull'estero, in oltre 90 paesi in tutto il mondo: per diventare oggi uno dei brand italiani nel settore dell'illuminazione più evoluti a livello internazionale.

## Spazio alla creatività. In tutte le sue forme.

Ogni strada ha i suoi confini e per superarli servono occhi, sensibilità, competenze ed emozioni diverse capaci di interpretare un mondo che cambia. Così Studio Italia Design ha deciso di farsi accompagnare da designer, ricercatori e progettisti famosi di varie nazionalità e background. Un pool di creativi che insieme al brand reinterpretano gli oggetti come veri e propri elementi di arredo, dove la sorgente luminosa è libera di giocare con i volumi, i riflessi, le trasparenze, le linee e tutte le sfumature della materia. Infinite nuove collezioni unite dall'eccellenza produttiva di sempre.

## Per illuminare ogni esigenza dell'abitare.

Il percorso dell'innovazione passa anche attraverso la massima personalizzazione: la possibilità di rispondere ai nuovi stili di vita grazie a prodotti pensati ad hoc per i vari contesti dell'abitare e a soluzioni su misura studiate insieme ai protagonisti dell'architettura contemporanea.

Ancora una nuova frontiera che Studio Italia Design percorre nel solco della sua esperienza: integrando materiali eterogenei, classicismo e avanguardia, artigianato e tecnologia. Uno sguardo a quella strada dove tutto è iniziato e l'entusiasmo di raggiungere la prossima destinazione.

STUDIO  
ITALIA DESIGN  
LIGHTING MAKERS

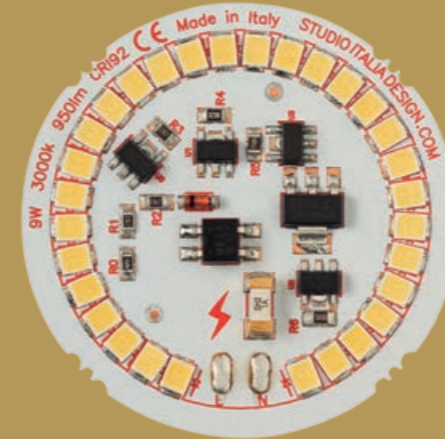

**9W**  
 2700K 900lm  
 3000K 950lm

**CRI92**  
 MacAdam 3-Step

Dimmerabile con varialuce a taglio di fase  
 Dimmable with phase cut dimming

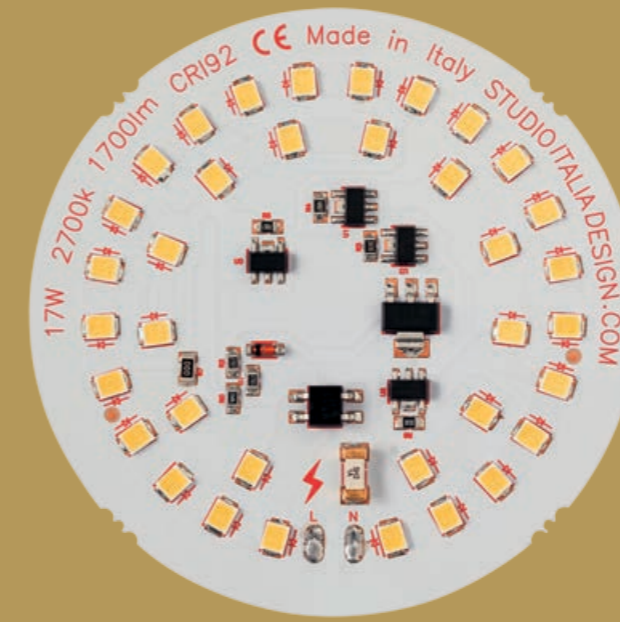

**17W**  
 2700K 1700lm  
 3000K 1800lm

**CRI92**  
 MacAdam 3-Step

Dimmerabile con varialuce a taglio di fase  
 Dimmable with phase cut dimming



Cos'è il MacAdam Step?  
 Scansiona il QR Code e scopri subito!  
 What is MacAdam Step?  
 Scan the QR Code and find out now!



Cos'è il CRI?  
 Scansiona il QR Code e scopri subito!  
 What is CRI?  
 Scan the QR Code and find out now!



Il kelvin (K) è l'unità di misura del colore della luce. Scopri di più!  
 The kelvin (K) is the light color unit measurement. Find out more!



Il lumen (lm) è l'unità di misura del flusso luminoso. Scopri di più!  
 The lumen (lm) is the unit of the luminous flux. Find out more!

ANNO | YEAR

1878

Edison inventa la lampadina ad incandescenza.  
 Edison invented the first incandescent light bulb.

1901

Vengono sviluppate le prime lampade a scarica a vapori di mercurio.  
 The first mercury vapour discharge lamps were developed.

1910

Viene brevettata la prima lampadina ad uso commerciale.  
 The first light bulb was patented for commercial use.

1926

Viene brevettata la lampada a fluorescenza.  
 The fluorescent lamp was patented.

1962

Viene brevettato il LED.  
 LED was patented.

1978

Appaiono le prime lampadine a basso consumo (CFL).  
 The first energy saving light bulbs (CFL) was appeared.

1993

Viene inventata la prima lampadina LED.  
 The first LED light source was developed.

2007

Appaiono le prime lampadine a LED retrofit.  
 The first retrofit LED bulbs appeared.

2015

Studio Italia Design propone le prime lampade con chip integrato LED a tensione di rete.  
 Studio Italia Design offered its first lighting fixtures with

Il 90% della collezione SID utilizza la tecnologia LED a tensione di rete.  
 90% of SID collection uses mains voltage LED technology.

2016

SID lancia i propri moduli LED a tensione di rete studiati e realizzati internamente (Made in Italy).  
 SID launches mains voltage LED modules designed and manufactured in house (Made in Italy).

SID lancia i moduli LED a tensione ad alta efficienza (Made in Italy). integrated mains voltage LED chip.  
 SID launches high efficiency mains voltage LED modules (Made in Italy).

2017

Indice Alfabetico/Alphabetic Index



A-Tube 132

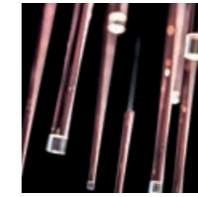

A-Tube Nano 120

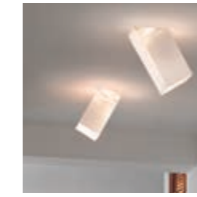

Beetle 322



Blow 312



Bugia 42



Frozen 110



Kelly 198

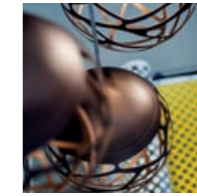

Kelly Cluster 224



Laser Cube 174



Maggio 246

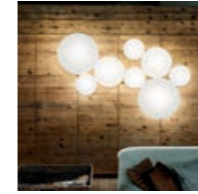

Make-Up 316



Millo 332



Nautilus 26

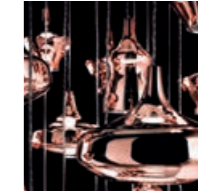

Nostalgia 260



Pin-Up 88

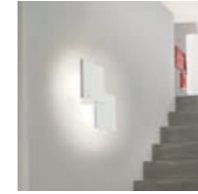

Puzzle 140



Puzzle Round 160

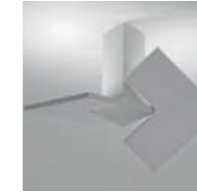

Puzzle Twist 152



Rain 72



Random 294



Shelf 104



Sky-Fall 10



Spider 54



Sugegasa 186



Thor 178



Vapor 338

# THE LIGHTING MAKERS 2017

## SUSPENSIONS



- A-Tube 132
- A-Tube Nano 120
- Frozen 110
- Kelly 198
- Kelly Cluster 224
- Maggio 246
- Nostalgia 260
- Rain 72
- Random 294
- Sky-Fall 10
- Spider 54
- Sugegasa 186



WALL

- Beetle 322
- Kelly 198
- Laser Cube 174
- Make-Up 316
- Millo 332
- Nautilus 26
- Pin-Up 88
- Puzzle 140
- Puzzle Round 160
- Puzzle Twist 152
- Thor 178

## CEILING



- A-Tube 132
- Beetle 322
- Bugia 42
- Frozen 110
- Make-Up 316
- Millo 332
- Pin-Up 88
- Puzzle 140
- Puzzle Round 160
- Puzzle Twist 152
- Thor 178



FLOOR

- Kelly 198
- Puzzle Twist 152
- Vapor 338



TABLE

- Blow 312
- Kelly 198

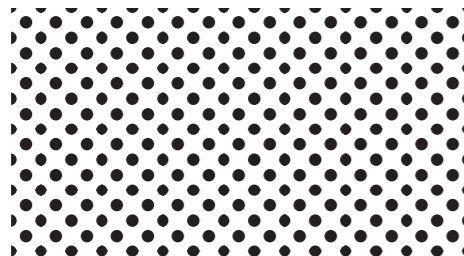
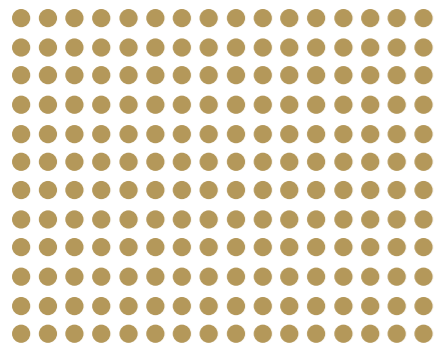

---

## SKYFALL

design: Studio Italia Design 2014

---

LA FORMA RICORDA I DECANTER DEI VINI PREGIATI IN PREZIOSO VETRO SOFFIATO CHE SI FONDONO CON IL PROGRESSO, UNENDO COSÌ LA MAESTRIA NELL'ARTE DEL VETRO CON LE NUOVISSIME TECNOLOGIE LED. SOSPENSIONE CHE NON SOLO INCANTA DI RICORDI MA CHE EMOZIONA, SINGOLARMENTE O IN COMPOSIZIONI MULTIPLE.

IT'S SHAPE REMINDS YOU OF A PRECIOUS BLOWN GLASS DECANTER USED FOR HIGH QUALITY WINES BUT AT THE SAME TIME SHOWS PROGRESS, PUTTING TOGETHER THE SKILL IN THE ART OF BLOWN GLASS AND THE MOST UP TO DATE LED AND FINISHING TECHNOLOGIES. SUSPENSION LAMP THAT NOT ONLY BRINGS BACK WARM MEMORIES BUT CREATES EVOCATIVE NEW IDEAS IN DESIGN, INDIVIDUALLY OR IN CLUSTERS.







SKYFALL  
STUDIO  
ITALIA  
DESIGN

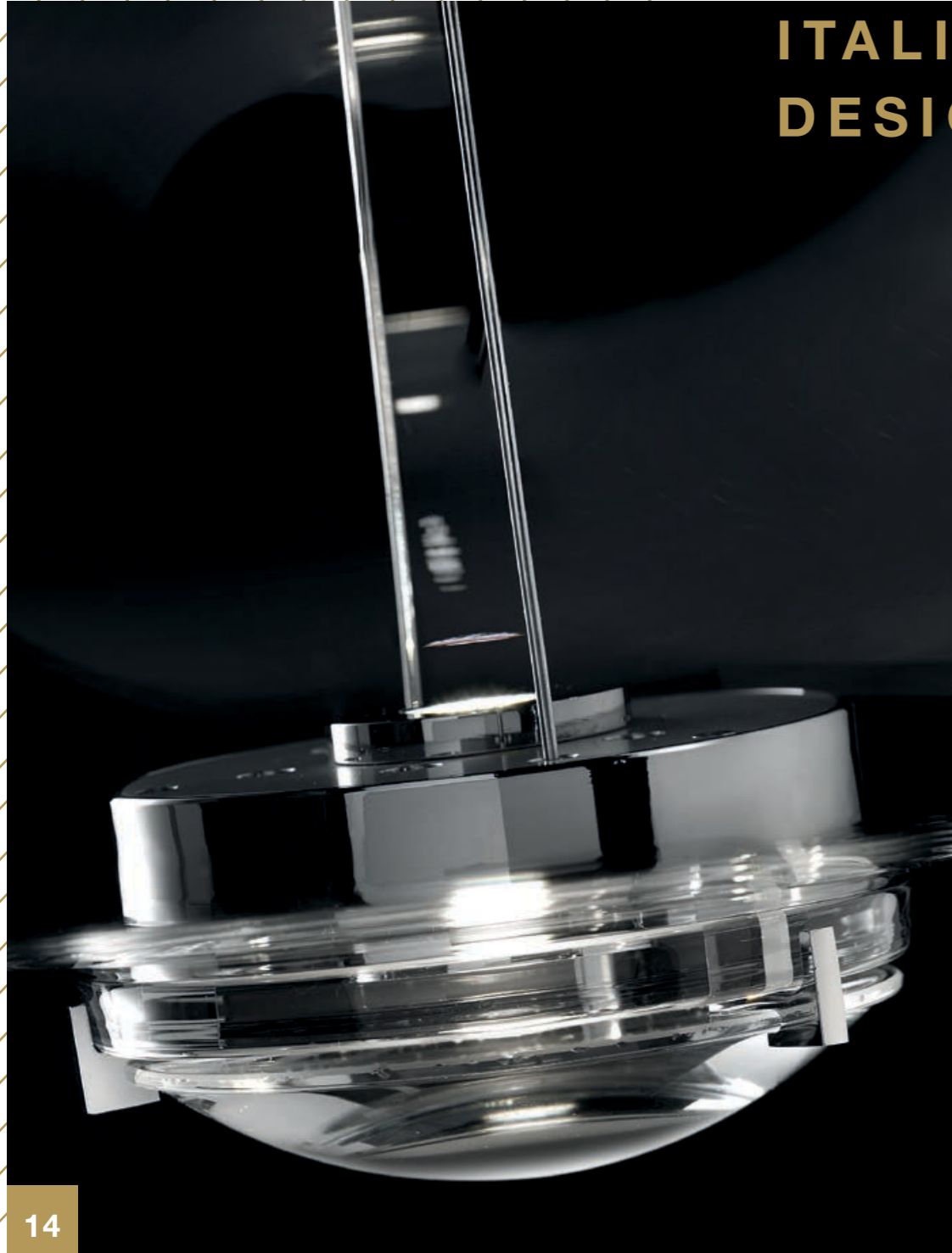



---

SKYFALL

---









# SKY-FALL

MODELLO | MODEL LAMPADINA | LAMP MONTATURA | FRAME DIFFUSORE | DIFFUSER CODICE | CODE

## Sky-Fall Medium Pendant | Sospensione

<p>[SO1]</p>	<p><b>2700K</b> 2x10W   1895 lm 350 mA CRI 95 MacAdam 3-Step</p> <p><b>LED and DRIVER</b> included</p>	<p>chromo chrome</p>	<p>cristallo crystal</p> <p>rame lucido metallizzato glossy copper metallized</p> <p>chromo chrome</p> <p>oro rosa rose gold</p> <p>Vetro Soffiato Blown Glass</p>	<p>148001</p> <p>148002</p> <p>148005</p> <p>148008</p>
<p>Peso netto: 1.65 Kg Weight net:</p>		<p><b>Confezione Packaging</b></p>	<p>Peso lordo: 3.14 Kg Weight gross:</p>	<p>n. Colli: 2 n. Pack:</p> <p>Volume m<sup>3</sup>: 0.059 Volume m<sup>3</sup>:</p>

## Sky-Fall Large Pendant | Sospensione

<p>[SO]</p>	<p><b>2700K</b> 2x10W   1895 lm 350 mA CRI 95 MacAdam 3-Step</p> <p><b>LED and DRIVER</b> included</p>	<p>chromo chrome</p>	<p>cristallo crystal</p> <p>rame lucido metallizzato glossy copper metallized</p> <p>chromo chrome</p> <p>oro rosa rose gold</p> <p>Vetro Soffiato Blown Glass</p>	<p>148003</p> <p>148004</p> <p>148006</p> <p>148007</p>
<p>Peso netto: 3.05 Kg Weight net:</p>		<p><b>Confezione Packaging</b></p>	<p>Peso lordo: 6 Kg Weight gross:</p>	<p>n. Colli: 2 n. Pack:</p> <p>Volume m<sup>3</sup>: 0.116 Volume m<sup>3</sup>:</p>

# SKY-FALL

## system

MODELLO | MODEL INFO | INFO COLORE | COLOR SISTEMA | SYSTEM CODICE | CODE

## Sky-Fall Track Short Linear Track | Binario Lineare

<p>[TR1S]</p>	<p>Binario lineare multiplo mod. Sky-Fall massimo 3 sospensioni</p> <p>Multiple linear track mod. Sky-Fall max 3 suspensions</p>	<p>bianco opaco 9010 matt white 9010</p>	<p><b>Sky-Fall system</b></p>	<p>154031</p>
<p>Peso netto: 4.6 Kg Weight net:</p>		<p><b>Confezione Packaging</b></p>	<p>Peso lordo: 5.41 Kg Weight gross:</p>	<p>n. Colli: 1 n. Pack:</p> <p>Volume m<sup>3</sup>: 0.019 Volume m<sup>3</sup>:</p>

## Sky-Fall Track Long Linear Track | Binario Lineare

<p>[TR2S]</p>	<p>Binario lineare multiplo mod. Sky-Fall massimo 5 sospensioni</p> <p>Multiple linear track mod. Sky-Fall max 5 suspensions</p>	<p>bianco opaco 9010 matt white 9010</p>	<p><b>Sky-Fall system</b></p>	<p>154032</p>
<p>Peso netto: 8.2 Kg Weight net:</p>		<p><b>Confezione Packaging</b></p>	<p>Peso lordo: 9.45 Kg Weight gross:</p>	<p>n. Colli: 1 n. Pack:</p> <p>Volume m<sup>3</sup>: 0.031 Volume m<sup>3</sup>:</p>

## Sky-Fall Wall Canopy Wall Canopy | Rosone Parete

<p>[RP2]</p>	<p>Rosone a parete mod. Sky-Fall</p> <p>Wall bracket mod Sky-Fall</p>	<p>chromo chrome</p>	<p><b>Sky-Fall system</b></p>	<p>154039</p>
<p>Peso netto: 0.83 Kg Weight net:</p>		<p><b>Confezione Packaging</b></p>	<p>Peso lordo: --- Kg Weight gross:</p>	<p>n. Colli: 1 n. Pack:</p> <p>Volume m<sup>3</sup>: 0.005 Volume m<sup>3</sup>:</p>

Note | Notes: **TR1S** and **TR2S** - I Binari sono utilizzabili solo con le sospensioni Sky-Fall che dovranno essere separate dai rosoni ed installate sui binari. Per ogni sospensione dovrà essere installato nel binario il rispettivo trasformatore rimosso dal rosone originale.

**RP02** - Entrambi gli accessori nelle due diverse lunghezze sono inclusi nella confezione con il supporto a parete.

**TR1S** and **TR2S** - Lights Traks are only for Sky-Fall pendants. Each pendent should be separated from the canopy and installed on the track. Each pendent should be installed on the track using the transformer removed from the original canopy.

**RP02** - Both accessories in the two available lengths are supplied in the box with the wall bracket.

Note | Notes: .....

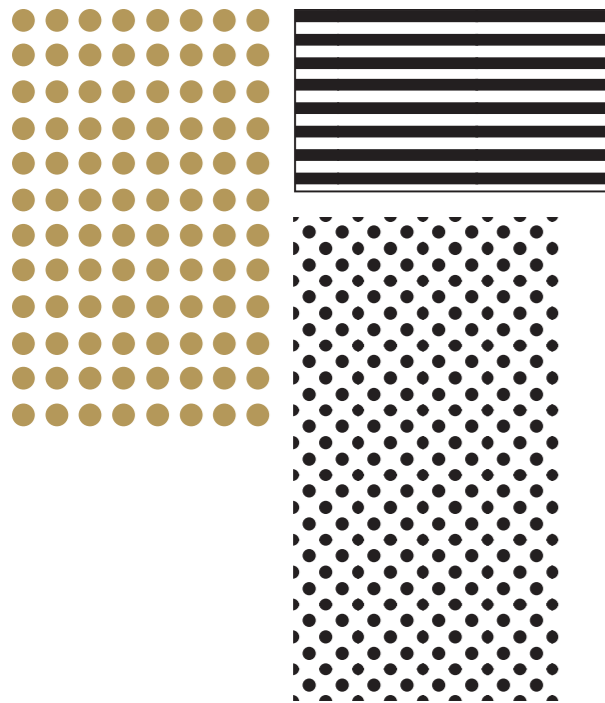

---

# NAUTILUS

design: Andrea Tosetto 2017

---

DESIGN DECISO E SOFISTICATO PER UNA APPLIQUE ALTAMENTE VERSATILE E FUNZIONALE. TRASPORTA LO STILE ITALIANO CONTEMPORANEO NEL MONDO DELL'ILLUMINAZIONE TECNOLOGICA DI QUALITÀ.

STRONG AND SOPHISTICATED DESIGN FOR A HIGHLY VERSATILE AND FUNCTIONAL WALL SCENCE. IT CARRIES CONTEMPORARY ITALIAN STYLE TO LUXURY TECHNICAL LIGHTING.



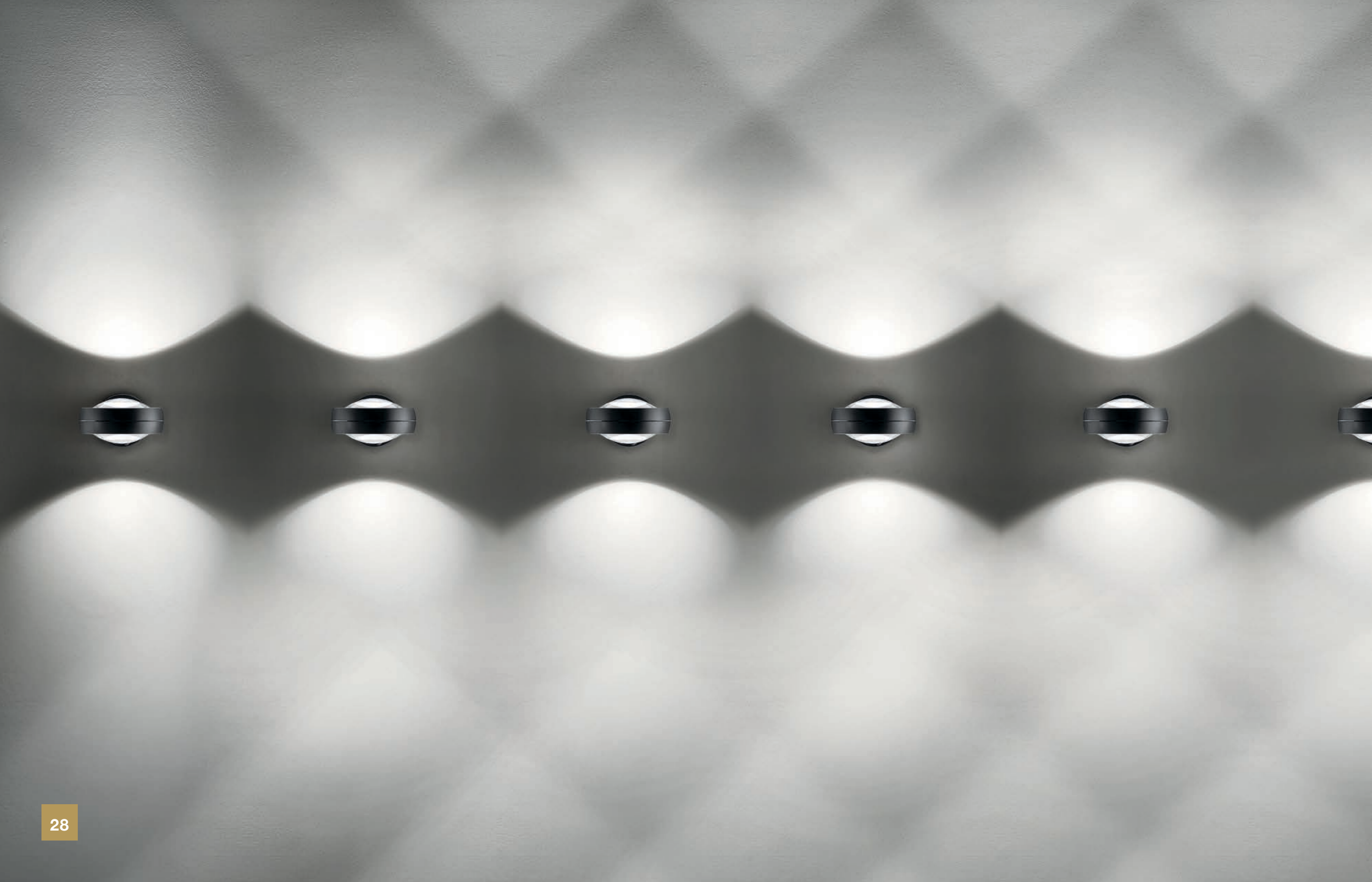







NAUTILUS  
STUDIO  
ITALIA  
DESIGN







# NAUTILUS



MODELLO | MODEL

LAMPADINA | LAMP

MONTATURA | FRAME

DIFFUSORE | DIFFUSER

CODICE | CODE

## Nautilus Wall | Parete

[AP-PL] [AP1-PL1]

<p>Ø cm 9 3.54"</p> <p>320°</p>	<p>AP-PL <b>2700K</b>                  2x15W   2400 lm  <b>LED COB</b>                  220-240V                  CRI 90                  MacAdam 3-Step</p>	<p>or</p> <p>Ø cm 13 5.11"</p> <p>90°</p> <p>max cm 28.5 11.22"</p> <p>min cm 16 6.3"</p> <p>max cm 19 7.48"</p>	<p>○ bianco opaco 9010 matt white 9010</p> <p>● nero opaco matt black</p> <p>○ cromo chrome</p> <p>● oro gold</p> <p>● oro rosa rose gold</p>	<p>165001</p> <p>165002</p> <p>165003</p> <p>165004</p> <p>165005</p>
<p>LED included</p>	<p>AP1-PL1 <b>3000K</b>                  2x15W   2600 lm  <b>LED COB</b>                  220-240V                  CRI 90                  MacAdam 3-Step</p>	<p>○ cromo chrome</p>	<p>○ bianco opaco 9010 matt white 9010</p> <p>● nero opaco matt black</p> <p>○ cromo chrome</p> <p>● oro gold</p> <p>● oro rosa rose gold</p>	<p>165006</p> <p>165007</p> <p>165008</p> <p>165009</p> <p>165010</p>
<p>0,5 m<sup>2</sup> CE Energy saving PG ip40 DIM TRIAC</p>		<p>Peso netto: 1.15 Kg Weight net:</p>	<p>Confezione Packaging</p>	<p>Peso lordo: -- Kg Weight gross:</p> <p>n. Colli: 1 n. Pack:</p> <p>Volume m<sup>3</sup>: 0.013 Volume m<sup>3</sup>:</p>



Note | Notes: LED con alimentazione diretta a tensione di rete (non necessita di driver LED). Dimmerabile con varialuce a taglio di fase.  
 LED with direct power supply to the AC line voltage (LED driver not required). Dimmable with phase cut dimming.

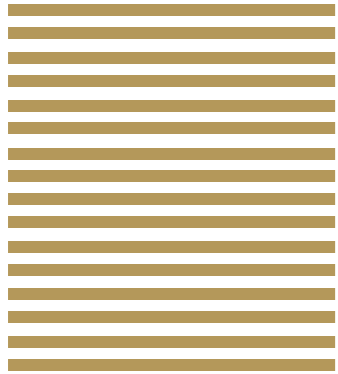
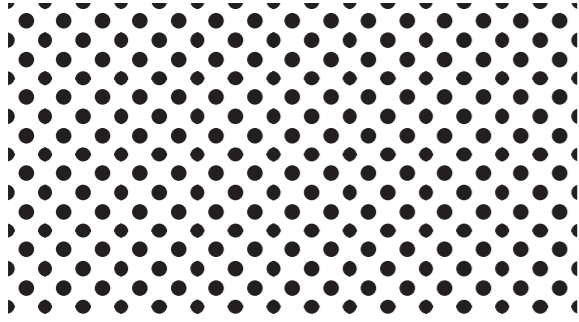

---

# BUGIA

design: Andrea Tosetto 2016

---

FINITURE ELEGANTI E BRILLANTI INCANTANO RIVELANDO UN EQUILIBRIO TRA LUCE INDIRECTA E DIRETTA, SENZA ABBAGLIARE. SOFISTICATA NELLE SUE FORME ROTONDE E PERFETTE CON UNO STILE SEMPLICE MA UNICO NEL SUO GENERE.

IT'S ELEGANT SHAPE AND BRIGHT FINISHING ENCHANT BY CREATING PERFECT HARMONY BETWEEN INDIRECT AND DIRECT LIGHTING WITHOUT GLARE. SOPHISTICATED WITH PERFECTLY WELL FORMED SHAPES IT HAS A SIMPLE BUT UNIQUE STYLE.







BUGIA  
STUDIO  
ITALIA  
DESIGN







# BUGIA

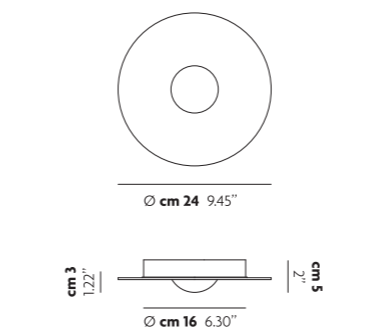
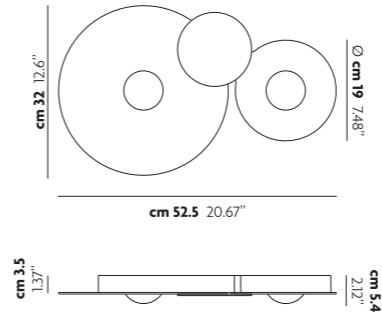
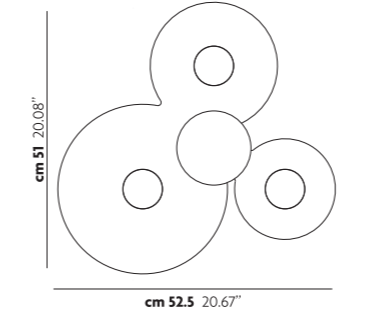

MODELLO   MODEL	LAMPADINA   LAMP	MONTATURA   FRAME	DIFFUSORE   DIFFUSER	CODICE   CODE	
<b>Bugia Single Ceiling   Plafoniera</b>					
[PL1-PL4] 	<b>PL1 2700K</b> 17W   1700 lm 210-250V CRI 92 MacAdam 3-Step LED		bianco opaco 9010 matt white 9010	bianco white oro gold cromo chrome rame lucido glossy copper	161019 161001 161002 161003
	or <b>PL4 3000K</b> 17W   1800 lm 210-250V CRI 92 MacAdam 3-Step LED			bianco white oro gold cromo chrome rame lucido glossy copper	161020 161004 161005 161006
0,5 m Energy saving PG ip20 DIM TRIAC Peso netto: 0.8 Kg <b>Confezione Packaging</b> Peso lordo: 1.46 Kg n. Colli: 2 Volume m <sup>3</sup> : 0.017 Weight net: Weight gross: n. Pack:					
<b>Bugia Double Ceiling   Plafoniera</b>					
[PL2-PL5] 	<b>PL2 2700K</b> 2x17W   3400 lm 210-250V CRI 92 MacAdam 3-Step LED		bianco opaco 9010 matt white 9010	bianco white oro gold cromo chrome rame lucido glossy copper	161021 161007 161008 161009
	or <b>PL5 3000K</b> 2x17W   3600 lm 210-250V CRI 92 MacAdam 3-Step LED			bianco white oro gold cromo chrome rame lucido glossy copper	161022 161010 161011 161012
0,5 m Energy saving PG ip20 DIM TRIAC Peso netto: 2.05 Kg <b>Confezione Packaging</b> Peso lordo: 4.91 Kg n. Colli: 2 Volume m <sup>3</sup> : 0.062 Weight net: Weight gross: n. Pack:					
<b>Bugia Triple Ceiling   Plafoniera</b>					
[PL3-PL6] 	<b>PL3 2700K</b> 3x17W   5100 lm 210-250V CRI 92 MacAdam 3-Step LED		bianco opaco 9010 matt white 9010	bianco white oro gold cromo chrome rame lucido glossy copper	161023 161013 161014 161015
	or <b>PL6 3000K</b> 3x17W   5400 lm 210-250V CRI 92 MacAdam 3-Step LED			bianco white oro gold cromo chrome rame lucido glossy copper	161024 161016 161017 161018
0,5 m Energy saving PG ip20 DIM TRIAC Peso netto: 2.8 Kg <b>Confezione Packaging</b> Peso lordo: 5.66 Kg n. Colli: 2 Volume m <sup>3</sup> : 0.062 Weight net: Weight gross: n. Pack:					

Note | Notes: LED con alimentazione diretta a tensione di rete (non necessita di driver LED). Dimmerabile con varialuce a taglio di fase.  
 LED with direct power supply to the AC line voltage (LED driver not required). Dimmable with phase cut dimming.

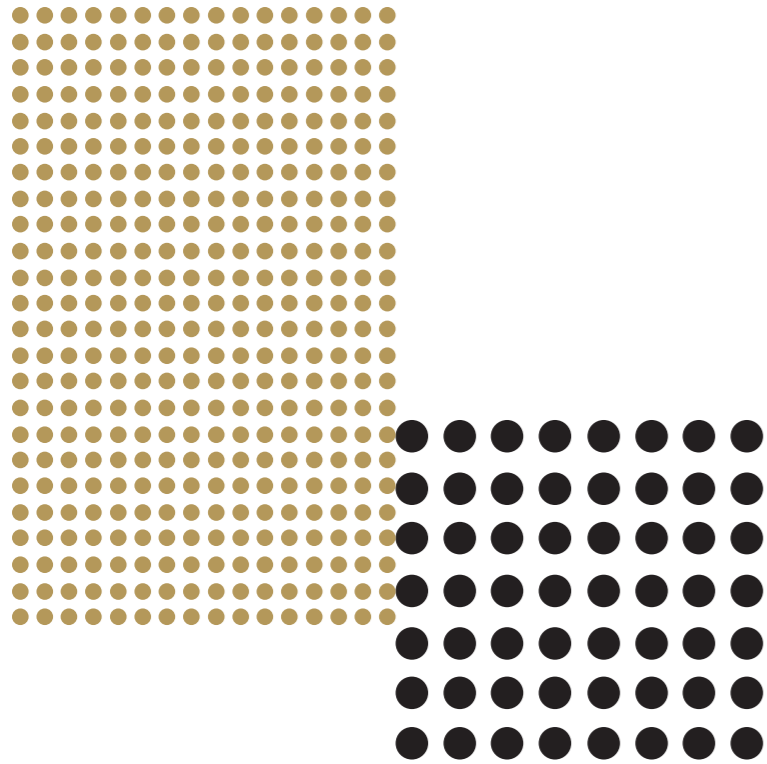

---

## SPIDER

design: Andrea Tosetto 2016

---

SINGOLARMENTE PERLE PREZIOSE, MAESTOSE NEI CLUSTER. SI DIRAMANO PER SCENDERE IN INNUMEREVOLI GIOCHI DI LUCE ORIENTABILI, LÌ DOVE SERVE E COME PIACE. DIFFERENTI FINITURE PREZIOSE PER RENDERLA UNICA ED INIMITABILE.

A PRECIOUS PEARL INDIVIDUALLY, MAJESTIC WHEN IN CLUSTERS. THE SPIDER CRAWLS UP ONLY TO THEN DROPS DOWN AND PERFORM A GREAT NUMBER OF LIGHTING EFFECTS, EACH LIGHTING BODY CAN BE ORIENTED TO SHINE LIGHT WHERE IT IS MOST REQUIRED. VARIOUS FINISHING DETAILS MAKE IT UNIQUE AND UNIMITABLE.



SPIDER  
STUDIO  
ITALIA  
DESIGN



SPIDER  
STUDIO  
ITALIA  
DESIGN









# SPIDER

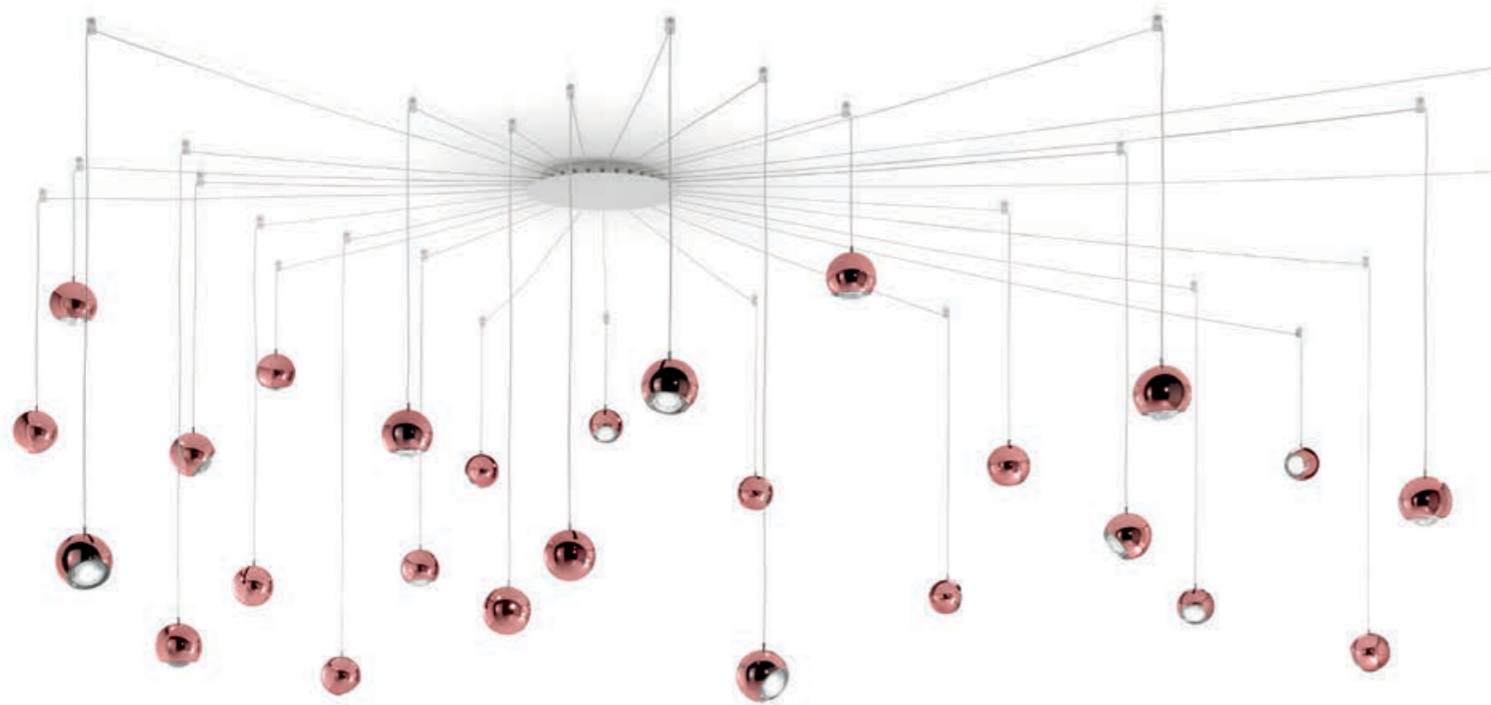

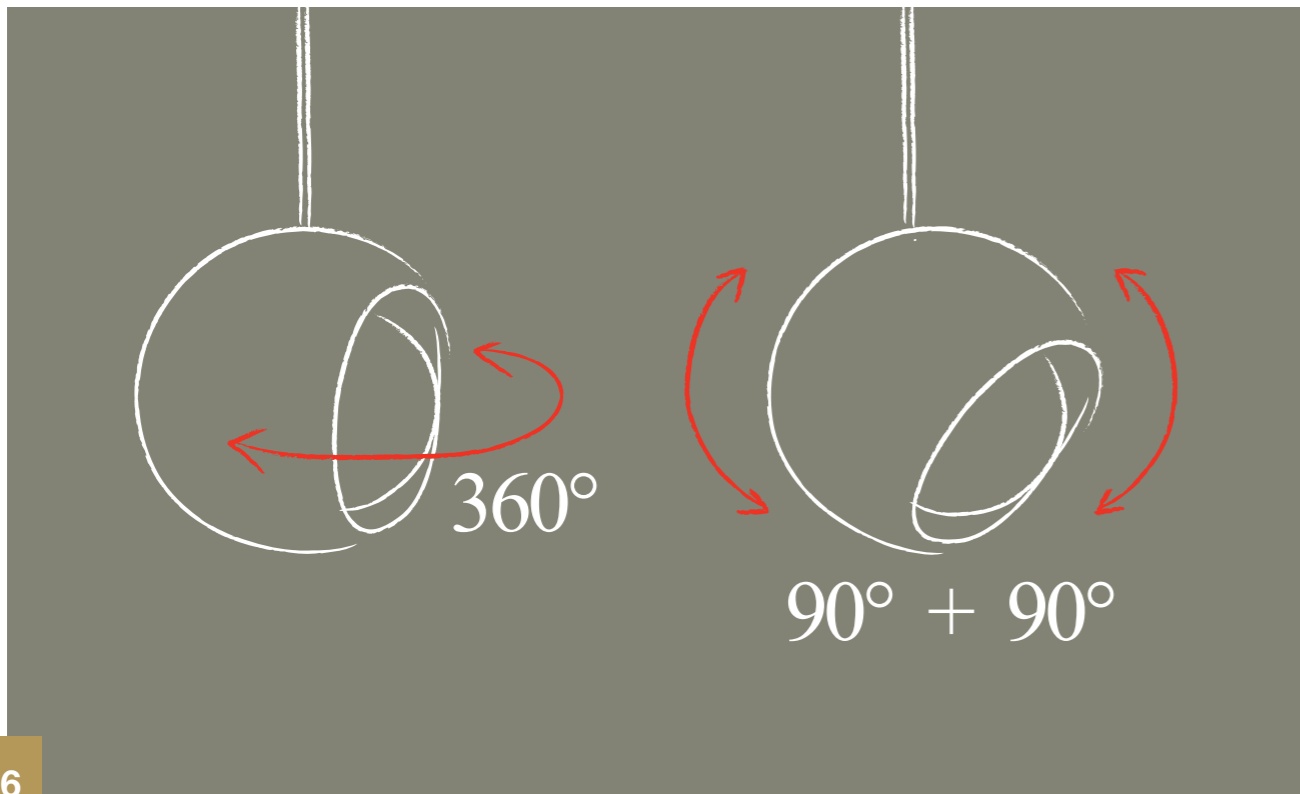



# SPIDER composition

## Spider example of composition

[Ex: 1] Single Radial Suspension | Sospensione Singola Decentrata

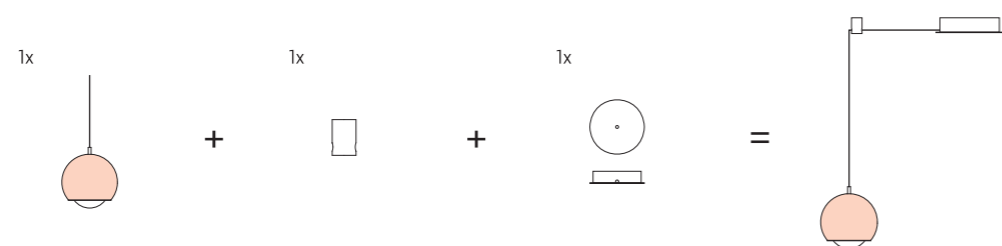

codice | code 160004 130009 154026

[Ex: 2] Cluster 3 Lights Composition | Composizione 3 Luci

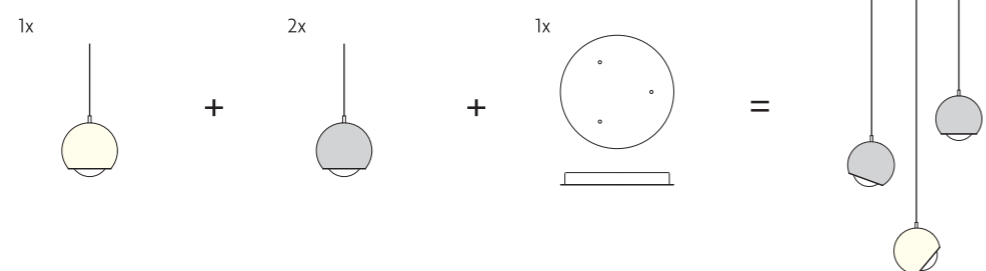

codice | code 160001 160002 154014

[Ex: 3] Radial 4 Lights Composition | Composizione 6 Luci Radiali



codice | code 160004 160001 130009 154027

[Ex: 4] Short Track with 4 Lights | Binario Lineare Multiplo Corto 4 Luci

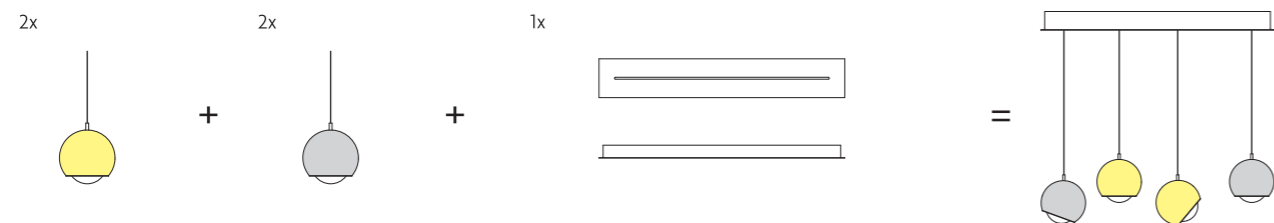

codice | code 160003 160002 154029

Note | Notes: .....

# SPIDER

MODELLO | MODEL

LAMPADINA | LAMP

MONTATURA | FRAME

DIFFUSORE | DIFFUSER

CODICE | CODE

## Spider Pendant | Sospensione

[S01]

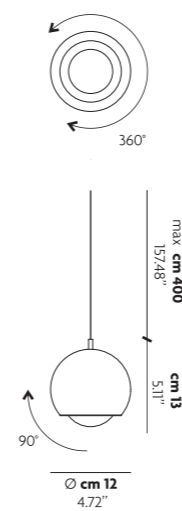

**LED**  
2700K  
9W | 900 lm  
210-250V  
CRI 92  
MacAdam 3-Step

● cromo  
chrome

● bianco opaco 9010  
matt white 9010

● nero opaco  
matt black

● cromo  
chrome

● oro  
gold

● oro rosa  
rose gold

160001

160005

160002

160003

160004



LED included

Peso netto: 0.8 Kg  
Weight net:

**Confezione Packaging**

Metallo Metal

Peso lordo: - Kg  
Weight gross:

Metallo Metal

n. Colli: 2  
n. Pack: 2  
Volume m³: 0.014

Le sospensioni devono essere installate sui **rosoni** presenti alle pagine 342-349  
The pendants must be installed with one of the **canopy** options listed on page 342-349  
Les suspensions doivent être installées sur les **patères** présentées dans les pages 342-349  
Die Hängeleuchten sollen auf die **Rosetten** auf Seiten 342-349 montiert werden  
Las lámparas de suspensión se deben instalar en los **rosetones** a pagina 342-349

Note | Notes: LED con alimentazione diretta a tensione di rete (non necessita di driver LED). Dimmerabile con varialuce a taglio di fase.  
LED with direct power supply to the AC line voltage (LED driver not required). Dimmable with phase cut dimming.

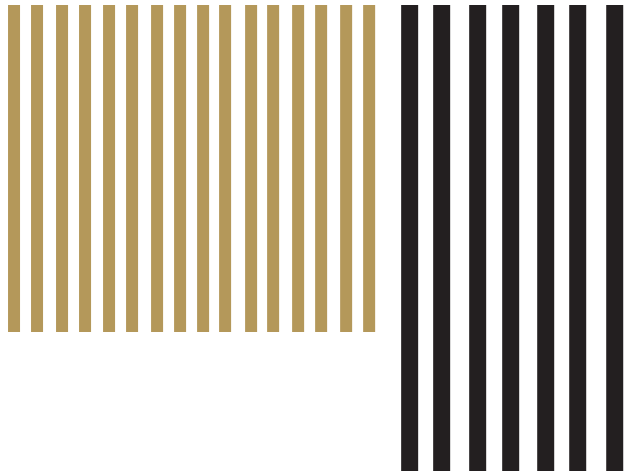

---

## RAIN

design: Andrea Tosetto 2015

---

ISPIRATA ALLA PIOGGIA DI PRIMAVERA CHE CADE SILENZIOSA E LEGGERA, NE CATTURA UN ATTIMO PORTANDO LA MAESTOSITÀ DELL'EVENTO ALL'INTERNO DEGLI AMBIENTI NELLA SUA SEMPLICITÀ. LINEE MINIMALISTE IMPREZIOSITE DAI DETTAGLI COLORATI LA RENDONO UNICA E SEMPRE DIVERSA.

RAIN IS INSPIRED BY THE SPRING RAIN THAT FALLS SILENT AND LIGHT AND CAPTURES A MOMENT IN TIME TO BRING YOU THE MAJESTY OF THIS NATURAL SPLENDOR INSIDE YOUR SPACES IN IT'S SIMPLICITY . MINIMAL LINES WITH PRECIOUS COLORED DETAILS MAKING RAIN UNIQUE AND ALWAYS DIFFERENT .



RAIN  
STUDIO  
ITALIA  
DESIGN



THE  
LIGHTING  
MAKERS  
2017









**RAIN  
STUDIO  
ITALIA  
DESIGN**







# RAIN composition

## Rain example of composition

[Ex: 1] Double Opposed Suspensions | Sospensioni Contrapposte

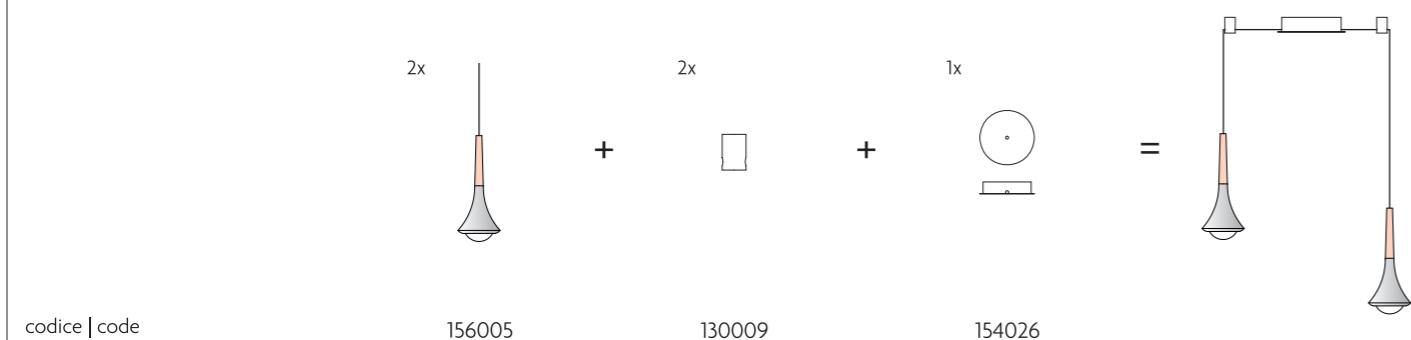

codice | code 156005 130009 154026

[Ex: 2] Wall Light Composition | Composizione a Parete

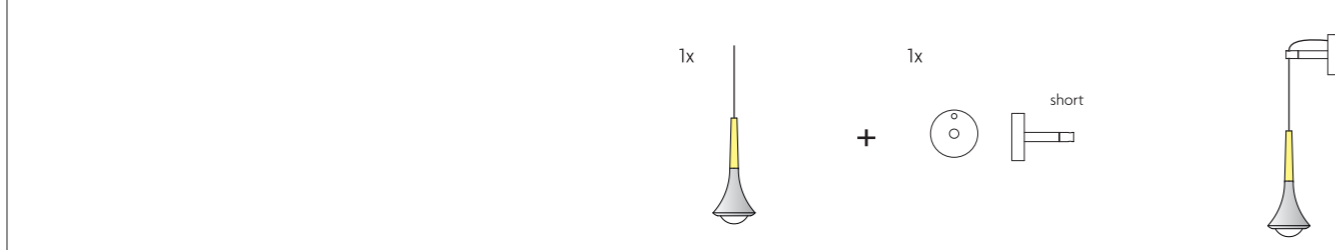

codice | code 156004 154038

[Ex: 3] Cluster Rectangular 7 Lights Composition | Composizione 7 Rettangolare Luci

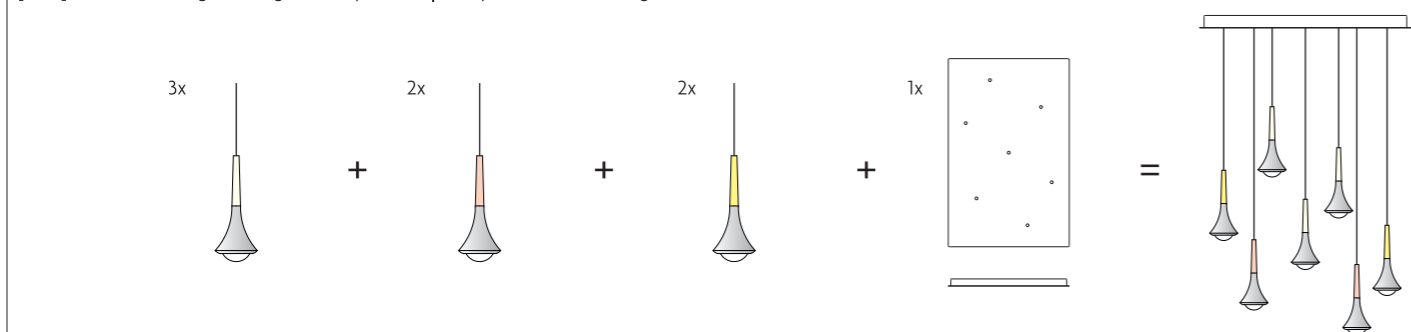

codice | code 156001 156005 156004 154019

[Ex: 4] Short Track with 7 Lights | Binario Lineare Multiplo Corto 7 Luci

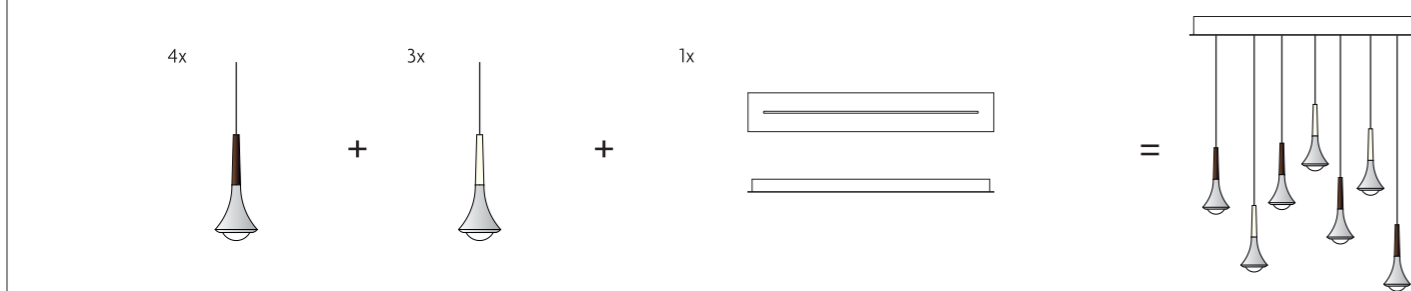

codice | code 156003 156001 154029

Note | Notes: .....

# RAIN

MODELLO | MODEL LAMPADINA | LAMP MONTATURA | FRAME DECORO | DECOR CODICE | CODE

## Rain Pendant | Sospensione

<p>[SO]</p> <p>Technical drawing showing dimensions: <math>\varnothing</math> cm 8.5 (3.34"), max cm 40 (15.748"), cm 10 (3.93"), cm 21 (8.266"), <math>\varnothing</math> cm 8.5 (3.34").</p>	<p><b>LED</b></p> <p>2700K 9W   900 lm 210-250V CRI 92 MacAdam 3-Step</p>	<p>LED included</p> <p>Metallo Metal</p>	<p>bianco opaco 9010 matt white 9010</p> <p>nero opaco matt black</p> <p>bronzo ramato coppery bronze</p> <p>romo chrome</p> <p>romo spazzolato brushed chrome</p> <p>oro gold</p> <p>oro rosa rose gold</p>	<p>156001</p> <p>156012</p> <p>156003</p> <p>156002</p> <p>156004</p> <p>156005</p>
<p>0,5 m<sup>2</sup> CE Energy saving P G ip 40 DIM TRIAC</p>		<p>Peso netto: 0.34 Kg Weight net:</p>	<p>Confezione Packaging</p> <p>Peso lordo: 0.61 Kg Weight gross:</p>	<p>n. Colli: 2 n. Pack: 2</p> <p>Volume m<sup>3</sup>: 0.006 Volume m<sup>3</sup>:</p>

Le sospensioni devono essere installate sui **rosoni** presenti alle pagine 342-349  
 The pendants must be installed with one of the **canopy** options listed on page 342-349  
 Les suspensions doivent être installées sur les **patères** présentées dans les pages 342-349  
 Die Hängeleuchten sollen auf die **Rosetten** auf Seiten 342-349 montiert werden  
 Las lámparas de suspensión se deben instalar en los **rosetones** a pagina 342-349

Note | Notes: LED con alimentazione diretta a tensione di rete (non necessita di driver LED). Dimmerabile con varialuce a taglio di fase.  
 LED with direct power supply to the AC line voltage (LED driver not required). Dimmable with phase cut dimming.

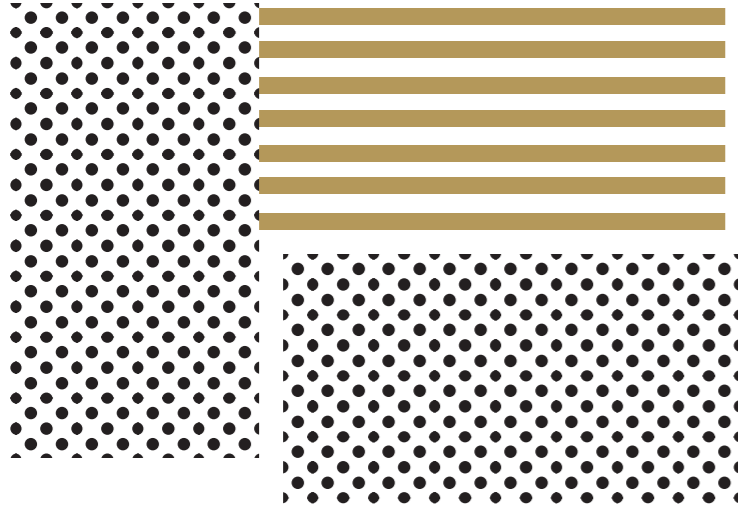

---

## PINUP

design: Andrea Tosetto 2015

---

ACCENTI DI LUCE RACCHIUSI IN UN DESIGN ORGANICO CHE UNA VOLTA DISCHIUSI E LASCIATI LIBERI DI ILLUMINARE CIÒ CHE CI INTERESSA STUPISCONO PER LA LORO SEMPLICITÀ E BELLEZZA GRAZIE AD UN CALDO LED.

LIGHT ACCENTS ENCLOSED IN AN ESSENTIAL DESIGN, ONCE RELEASED AND FREE TO SHINE AT OUR COMMAND, THEY AMAZE WITH THE SIMPLICITY AND BEAUTY OF THEIR WARM LED SOURCE.





PIN-UP  
STUDIO  
ITALIA  
DESIGN















# PINUP

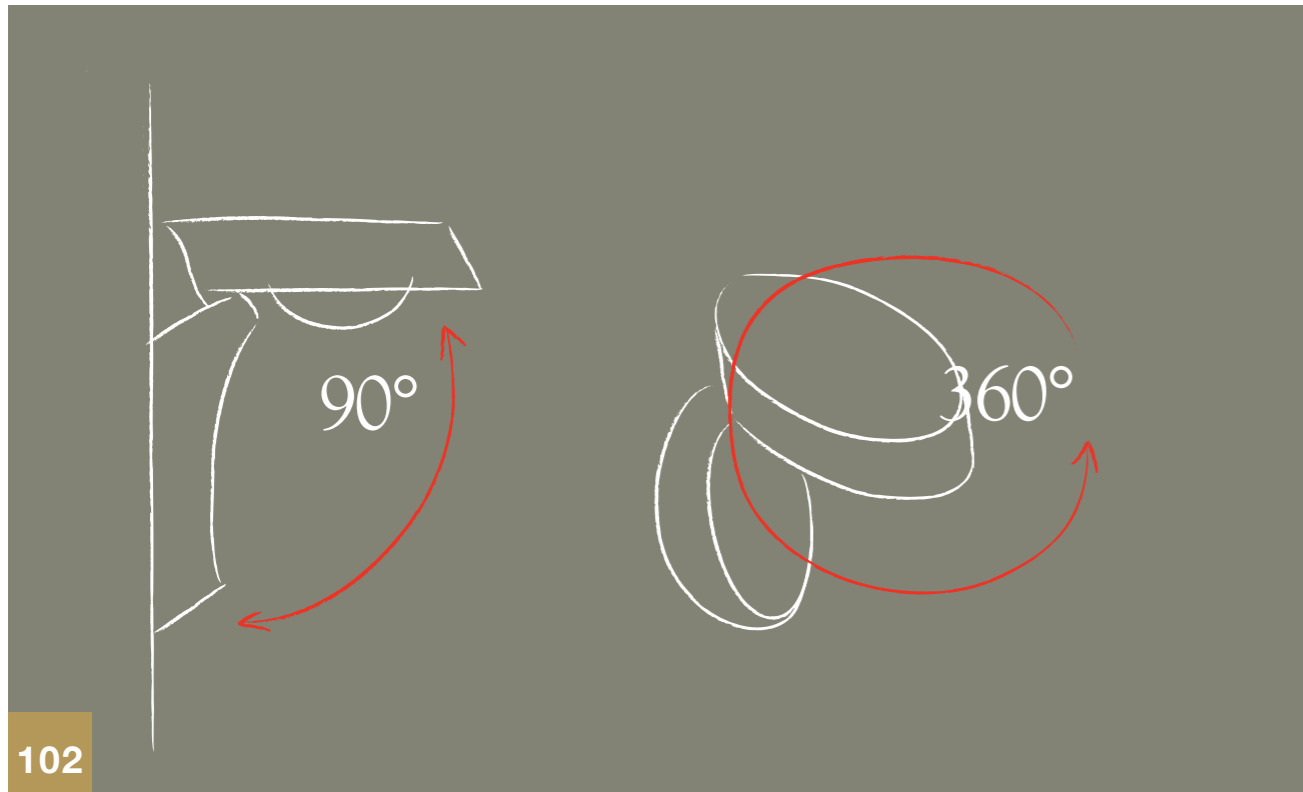

# PIN - UP

MODELLO   MODEL	LAMPADINA   LAMP	MONTATURA   FRAME	DIFFUSORE   DIFFUSER	CODICE   CODE
<b>Pin-Up</b> Wall & Ceiling   Parete & Plafoniera				
[AP-PL] [AP1-PL1]	<p>AP-PL <b>2700K</b> 9W   900 lm <b>LED</b> 210-250V CRI 92 MacAdam 3-Step</p> <p>or</p> <p>AP1-PL1 <b>3000K</b> 9W   950 lm <b>LED</b> 210-250V CRI 92 MacAdam 3-Step</p>	<p>bianco opaco 9016 matt white 9016</p> <p>bronz ramato coppery bronze</p> <p>romo chrome</p> <hr/> <p>bianco opaco 9016 matt white 9016</p> <p>bronz ramato coppery bronze</p> <p>romo chrome</p>	<p>no none</p>	<p>155001</p> <p>155002</p> <p>155003</p> <p>155004</p> <p>155005</p> <p>155006</p>
		<p>LED included</p>	<p>Metallo Metal</p>	<p>Peso netto: 1,15 Kg Weight net:</p> <p><b>Confezione Packaging</b></p> <p>Peso lordo: 1,4 Kg Weight gross:</p> <p>n. Colli: 1 n. Pack:</p> <p>Volume m<sup>3</sup>: 0,008 Volume m<sup>3</sup>:</p>
<p>0,5 m<sup>2</sup> CE Energy saving PG ip40 DIM TRIAC</p>				

Note | Notes: LED con alimentazione diretta a tensione di rete (non necessita di driver LED). Dimmerabile con varialuce a taglio di fase.  
LED with direct power supply to the AC line voltage (LED driver not required). Dimmable with phase cut dimming.

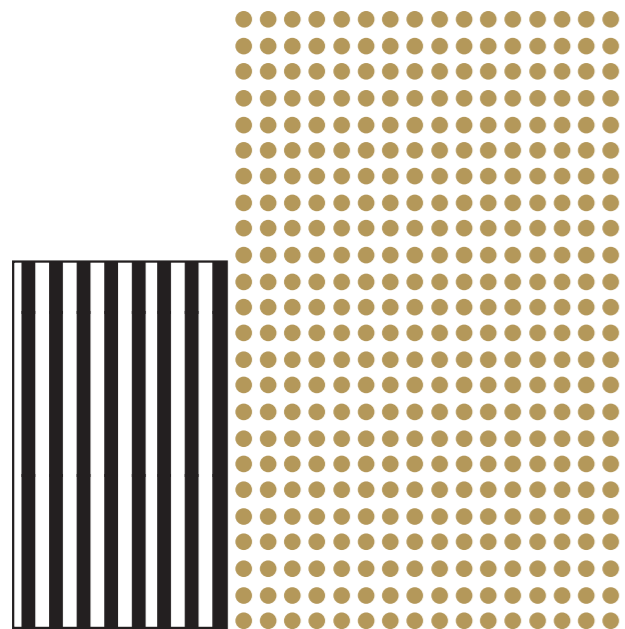

---

## SHELF

design: Studio Italia Design 2015

---

SOPRA LA MENSOLA NOI CI ABBIAMO MESSO LA LUCE , FACENDO INTRAVEDERE I SUOI OCCHI, LENTI IN PURO CRISTALLO CHE CREERANNO FANTASTICI GIOCHI DI LUCE SULLE VOSTRE PARETI.

WE HAVE PUT LIGHT ON A SHELF AND THROUGH ITS EYES, PURE CRYSTAL LENSES, WE CREATE FANTASTIC LIGHT EFFECTS ON YOUR WALLS.



SHELF  
STUDIO  
ITALIA  
DESIGN



# SHELF



MODELLO | MODEL

LAMPADINA | LAMP

MONTATURA | FRAME

DIFFUSORE | DIFFUSER

CODICE | CODE

## Shelf Single Wall | Parete

<p>[AP2-AP4]</p>	<p>AP4 <b>2700K</b> 17W   1700 lm <b>LED</b> 210-250V CRI 92 MacAdam 3-Step</p>	<p>bianco opaco 9016 matt white 9016</p>	<p>no none</p>	151005		
	<p>or</p> <p>AP2 <b>3000K</b> 17W   1800 lm <b>LED</b> 210-250V CRI 92 MacAdam 3-Step <b>LED</b> included</p>			151003		
<p>0,5 m<sup>3</sup> CE Energy saving PG ip 40 DIM TRIAC</p>		<p>Peso netto: 0,9 Kg Weight net:</p>	<p><b>Confezione Packaging</b></p>	<p>Peso lordo: 1,06 Kg Weight gross:</p>	<p>n. Colli: 1 n. Pack:</p>	<p>Volume m<sup>3</sup>: 0,004 Volume m<sup>3</sup>:</p>

## Shelf Double Wall | Parete

<p>[AP1-AP3]</p>	<p>AP3 <b>2700K</b> 2x17W   3400 lm <b>LED</b> 210-250V CRI 92 MacAdam 3-Step</p>	<p>bianco opaco 9016 matt white 9016</p>	<p>no none</p>	151004		
	<p>or</p> <p>AP1 <b>3000K</b> 2x17W   3600 lm <b>LED</b> 210-250V CRI 92 MacAdam 3-Step <b>LED</b> included</p>			151002		
<p>0,5 m<sup>3</sup> CE Energy saving PG ip 40 DIM TRIAC</p>		<p>Peso netto: 1,9 Kg Weight net:</p>	<p><b>Confezione Packaging</b></p>	<p>Peso lordo: 2,29 Kg Weight gross:</p>	<p>n. Colli: 1 n. Pack:</p>	<p>Volume m<sup>3</sup>: 0,012 Volume m<sup>3</sup>:</p>



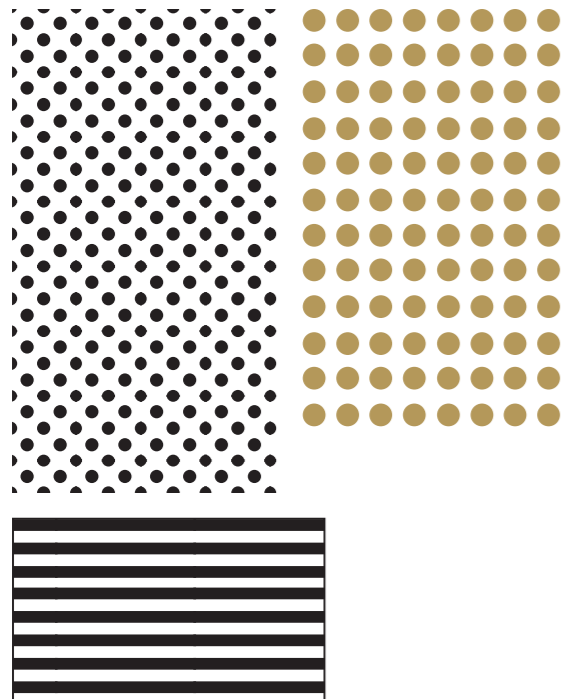

---

# FROZEN

design: Studio Italia Design 2015

---

PIATTA COME UN FOGLIO, DAL DESIGN MINIMALISTA LASCIA INTRAVEDERE I SUOI OCCHI, LENTI IN PURO CRISTALLO SIMILI A GHIACCIOLI CHE SAPRANNO DARE VITA, ATTRAVERSO EFFETTI LUMINOSI, A TUTTI GLI AMBIENTI.

FLAT LIKE A SHEET OF PAPER WITH A MINIMALIST DESIGN THAT ALLOWS YOU TO SEE IT'S EYES, LENSES MADE OF PURE CRYSTAL SIMILAR TO ICICLES WHICH WILL BRING ANY ENVIRONMENT TO LIFE THANKS TO THE EFFECTS THE LENSES CREATE.





FROZEN  
STUDIO  
ITALIA  
DESIGN





FROZEN



# FROZEN

MODELLO   MODEL	LAMPADINA   LAMP	MONTATURA   FRAME	DIFFUSORE   DIFFUSER	CODICE   CODE
<b>Frozen Small Ceiling   Plafoniera</b>				
[PL2-PL5] 	<b>PL5 2700K</b> 17W   1700 lm <b>LED</b> 210-250V CRI 92 MacAdam 3-Step or <b>PL2 3000K</b> 17W   1800 lm <b>LED</b> 210-250V CRI 92 MacAdam 3-Step <b>LED included</b>	bianco opaco 9016 matt white 9016 bronzo ramato coppery bronze	no none	149019 149020 149003 149007
Peso netto: 1.77 Kg <b>Confezione Packaging</b> Peso lordo: 2.23 Kg n. Colli: 1 Volume m <sup>3</sup> : 0.015 Weight net:				
<b>Frozen Medium Ceiling   Plafoniera</b>				
[PL1-PL4] 	<b>PL4 2700K</b> 2x17W   3400 lm <b>LED</b> 210-250V CRI 92 MacAdam 3-Step or <b>PL1 3000K</b> 2x17W   3600 lm <b>LED</b> 210-250V CRI 92 MacAdam 3-Step <b>LED included</b>	bianco opaco 9016 matt white 9016 bronzo ramato coppery bronze	no none	149017 149018 149002 149006
Peso netto: 3.27 Kg <b>Confezione Packaging</b> Peso lordo: 4.01 Kg n. Colli: 1 Volume m <sup>3</sup> : 0.028 Weight net:				
<b>Frozen Large Ceiling   Plafoniera</b>				
[PL-PL3] 	<b>PL3 2700K</b> 4x17W   6800 lm <b>LED</b> 210-250V CRI 92 MacAdam 3-Step or <b>PL 3000K</b> 4x17W   7200 lm <b>LED</b> 210-250V CRI 92 MacAdam 3-Step <b>LED included</b>	bianco opaco 9016 matt white 9016 bronzo ramato coppery bronze	no none	149015 149016 149001 149005
Peso netto: 7.78 Kg <b>Confezione Packaging</b> Peso lordo: 10.04 Kg n. Colli: 1 Volume m <sup>3</sup> : 0.115 Weight net:				
<b>Frozen Long Pendant   Sospensione</b>				
[SO-SO2] 	<b>SO2 2700K</b> ▲ 2x17W   3400 lm ▼ 3x17W   5100 lm <b>LED</b> 210-250V CRI 92 MacAdam 3-Step or <b>SO 3000K</b> ▲ 2x17W   3600 lm ▼ 3x17W   5400 lm <b>LED</b> 210-250V CRI 92 MacAdam 3-Step <b>LED included</b>	bianco opaco 9016 matt white 9016 bronzo ramato coppery bronze	no none	149011 149012 149004 149008
Peso netto: 14.73 Kg <b>Confezione Packaging</b> Peso lordo: 17.27 Kg n. Colli: 1 Volume m <sup>3</sup> : 0.058 Weight net:				

Note | Notes: LED con alimentazione diretta a tensione di rete (non necessita di driver LED). Dimmerabile con varialuce a taglio di fase.  
 LED with direct power supply to the AC line voltage (LED driver not required). Dimmable with phase cut dimming.



---

## A-TUBE NANO

---

design: Studio Italia Design 2016

---

LINEE SOTTILI CHE VENGONO IMPREZIOSITE DAL DETTAGLIO CRISTALLO TRASPARENTE CHE QUANDO ILLUMINATO RISALTA COME LA RUGIADA IN PRIMAVERA. GRAZIE ALLA SUA MODULARITÀ CREA BELLISSIME COMPOSIZIONI CLUSTER.

THIN LINES HAVE A PRECIOUS TOUCH WITH A TRANSPARENT GLASS DETAIL THAT SHINES LIKE MORNING DEW IN THE SUNSHINE ON A SPRING MORNING. IT ALLOWS YOU TO CREATE BEAUTIFUL CLUSTERS THANKS TO IT'S MODULARITY.

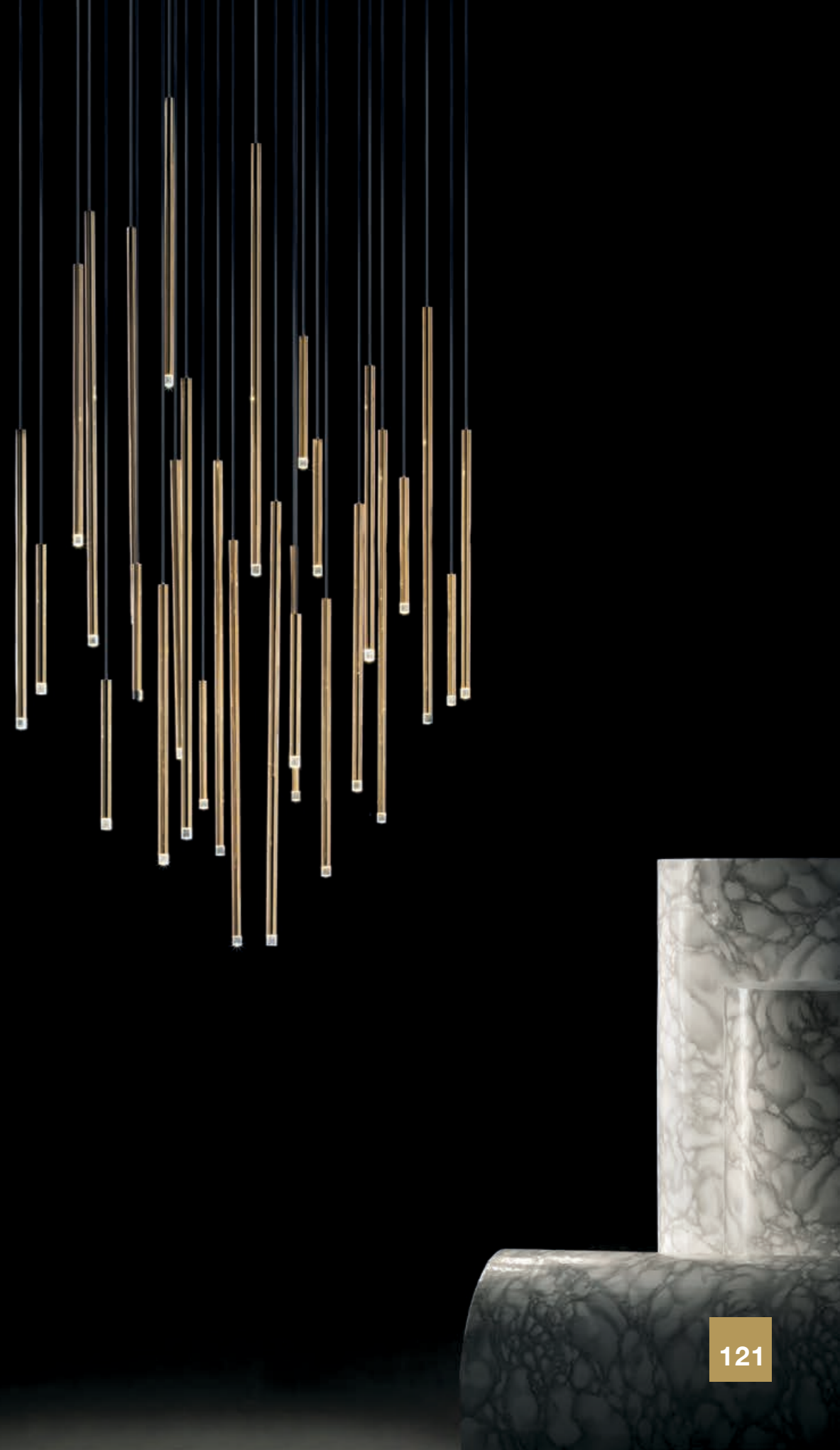



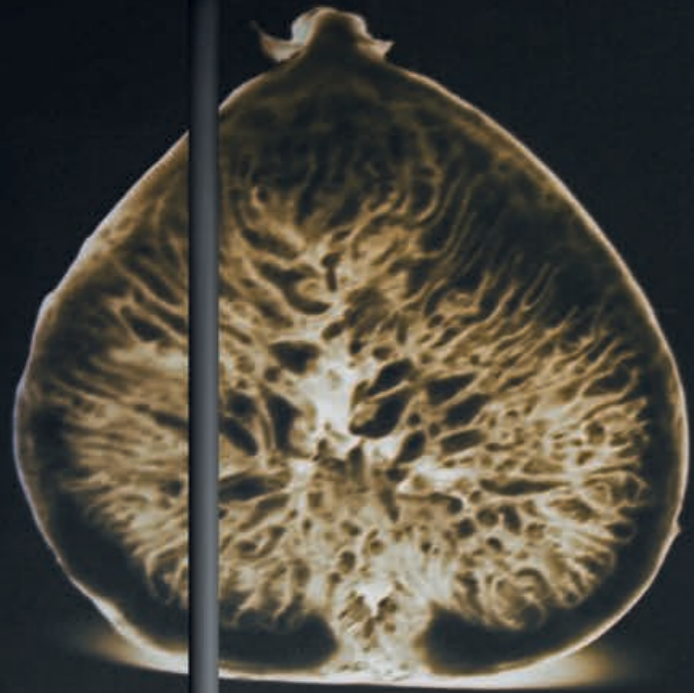



A-TUBE  
NANO  
STUDIO  
ITALIA  
DESIGN





# A-TUBE NANO composition

## A-Tube Nano example of composition

[Ex: 1] Single Radial Suspension | Sospensione Singola Decentrata

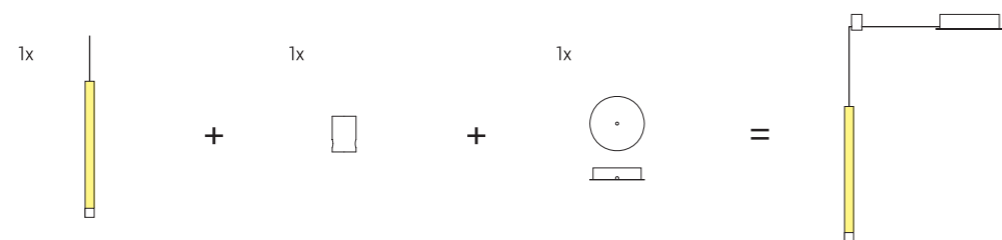

codice | code 158003 130009 154026

[Ex: 2] Cluster 3 Lights Composition | Composizione 3 Luci

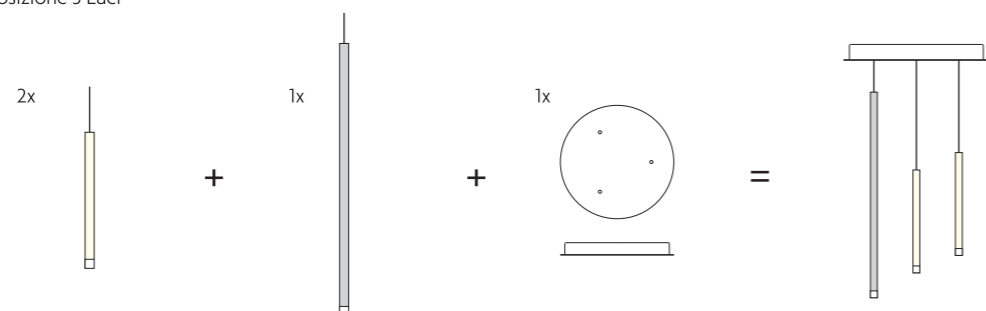

codice | code 158005 158006 154014

[Ex: 3] Radial 6 Lights Composition | Composizione 6 Luci Radiali

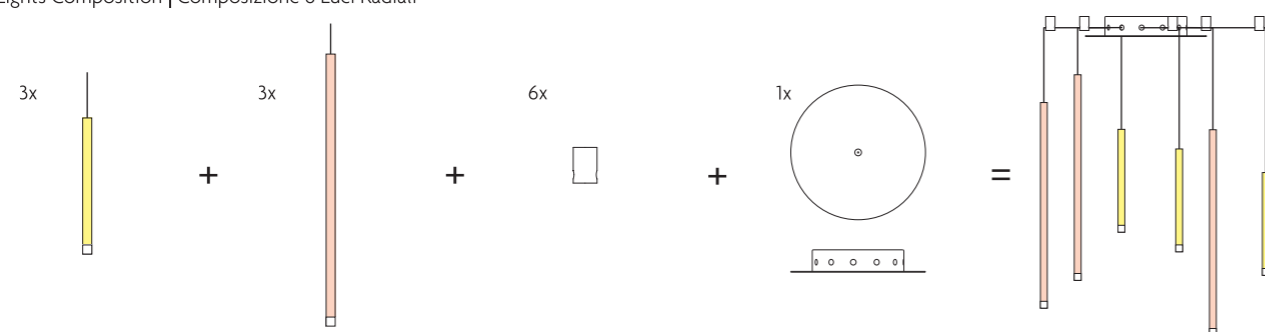

codice | code 158003 158008 130009 154027

[Ex: 4] Short Track with 7 Lights | Binario Lineare Multiplo Corto 7 Luci

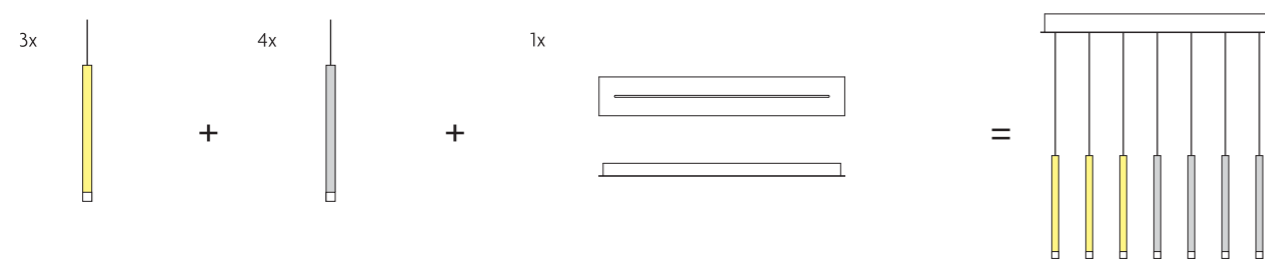

codice | code 158003 158002 154029

Note | Notes: .....

# A-TUBE NANO

MODELLO | MODEL LAMPADINA | LAMP MONTATURA | FRAME DIFFUSORE | DIFFUSER CODICE | CODE

## A-Tube Nano Small Pendant | Sospensione

[SO1]		<b>2700K</b> 2.5W   140 lm <b>LED COB</b> 210-250V CRI 80 MacAdam 3-Step LED included	bianco opaco 9010 matt white 9010 nero opaco matt black cromo chrome oro gold oro rosa rose gold Metallo Metal	trasparente clear Policarbonato Polycarbonate	158001 158013 158002 158003 158004	
0,5 m <sup>2</sup> CE Energy saving PG ip40 DIM TRIAC		Peso netto: Weight net: 0.4 Kg	<b>Confezione Packaging</b>	Peso lordo: Weight gross: 0.58 Kg	n. Colli: n. Pack: 2	Volume m <sup>3</sup> : Volume m <sup>3</sup> : 0.004

## A-Tube Nano Medium Pendant | Sospensione

[SO2]		<b>2700K</b> 2.5W   140 lm <b>LED COB</b> 210-250V CRI 80 MacAdam 3-Step LED included	bianco opaco 9010 matt white 9010 nero opaco matt black cromo chrome oro gold oro rosa rose gold Metallo Metal	trasparente clear Policarbonato Polycarbonate	158005 158014 158006 158007 158008	
0,5 m <sup>2</sup> CE Energy saving PG ip40 DIM TRIAC		Peso netto: Weight net: 0.5 Kg	<b>Confezione Packaging</b>	Peso lordo: Weight gross: 0.68 Kg	n. Colli: n. Pack: 2	Volume m <sup>3</sup> : Volume m <sup>3</sup> : 0.004

## A-Tube Nano Large Pendant | Sospensione

[SO3]		<b>2700K</b> 2.5W   140 lm <b>LED COB</b> 210-250V CRI 80 MacAdam 3-Step LED included	bianco opaco 9010 matt white 9010 nero opaco matt black cromo chrome oro gold oro rosa rose gold Metallo Metal	trasparente clear Policarbonato Polycarbonate	158009 158015 158010 158011 158012	
0,5 m <sup>2</sup> CE Energy saving PG ip40 DIM TRIAC		Peso netto: Weight net: 0.6 Kg	<b>Confezione Packaging</b>	Peso lordo: Weight gross: 0.95 Kg	n. Colli: n. Pack: 2	Volume m <sup>3</sup> : Volume m <sup>3</sup> : 0.007

Le sospensioni devono essere installate sui **rosoni** presenti alle pagine 342-349  
 The pendants must be installed with one of the **canopy** options listed on page 342-349  
 Les suspensions doivent être installées sur les **patères** présentées dans les pages 342-349  
 Die Hängeleuchten sollen auf die **Rosetten** auf Seiten 342-349 montiert werden  
 Las lámparas de suspensión se deben instalar en los **rósetones** a pagina 342-349

Note | Notes: LED con alimentazione diretta a tensione di rete (non necessita di driver LED). Dimmerabile con varialuce a taglio di fase.  
 LED with direct power supply to the AC line voltage (LED driver not required). Dimmable with phase cut dimming.



---

## A-TUBE

design: Studio Italia Design 2013

---

UNA LUCE CHE PUNTA DIRETTA ALL'OBIETTIVO. UNA LINEA SEMPLICE CHE NON SMETTE DI RINNOVARSI. SEMPRE PIÙ MODERNA E ALLA MODA.

A SOURCE OF LIGHT THAT GETS STRAIGHT TO THE POINT, A SIMPLE LINE THAT KEEPS RENEWING ITSELF, ALWAYS UP TO DATE AND KEEPING PACE WITH FASHION.







A-TUBE  
STUDIO  
ITALIA  
DESIGN

# A-TUBE

MODELLO | MODEL      LAMPADINA | LAMP      MONTATURA | FRAME      DIFFUSORE | DIFFUSER      CODICE | CODE

## A-Tube Small Pendant | Sospensione

[SO2] 	GU10 Par 16 1x max 40W eco  or  GU10 Par 16 LED 1x max available [L max cm 8.5]  Lampadine non include Bulbs not included	bianco opaco 9010 matt white 9010  nero opaco matt black  bronzo ramato coppery bronze  Metallo Metal	no none	096017
				096032
				096027
0,5 m/s    CE    F    energy saving    PG    IP20    DIM    Peso netto: 1.25 Kg <b>Confezione Packaging</b> Peso lordo: 1.67 Kg    n. Colli: 1    Volume m³: 0.012 Weight net:    Weight gross:    n. Pack:				

## A-Tube Medium Pendant | Sospensione

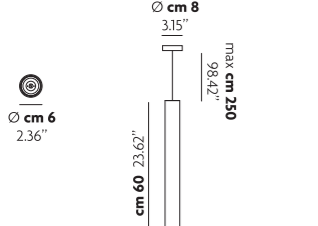
[SO3] 	GU10 Par 16 1x max 40W eco  or  GU10 Par 16 LED 1x max available [L max cm 8.5]  Lampadine non include Bulbs not included	bianco opaco 9010 matt white 9010  nero opaco matt black  bronzo ramato coppery bronze  Metallo Metal	no none	096019
				096034
				096028
0,5 m/s    CE    F    energy saving    PG    IP20    DIM    Peso netto: 1.55 Kg <b>Confezione Packaging</b> Peso lordo: 2.14 Kg    n. Colli: 1    Volume m³: 0.017 Weight net:    Weight gross:    n. Pack:				

## A-Tube Large Pendant | Sospensione

[SO4] 	GU10 Par 16 1x max 40W eco  or  GU10 Par 16 LED 1x max available [L max cm 8.5]  Lampadine non include Bulbs not included	bianco opaco 9010 matt white 9010  nero opaco matt black  bronzo ramato coppery bronze  Metallo Metal	no none	096021
				096036
				096029
0,5 m/s    CE    F    energy saving    PG    IP20    DIM    Peso netto: 2 Kg <b>Confezione Packaging</b> Peso lordo: 2.8 Kg    n. Colli: 1    Volume m³: 0.028 Weight net:    Weight gross:    n. Pack:				

Note | Notes: Le sospensioni **A-Tube** possono essere installate sui rosoni presenti alla pagina 342  
**A-Tube** suspension can be installed on the canopies shown on page 342

# A-TUBE

MODELLO | MODEL      LAMPADINA | LAMP      MONTATURA | FRAME      DIFFUSORE | DIFFUSER      CODICE | CODE

## A-Tube Mini Ceiling | Plafoniera

[PL6] 	GU10 Par 16 1x max 40W eco  or  GU10 Par 16 LED 1x max available [L max cm 9]  Lampadine non include Bulbs not included	bianco opaco 9010 matt white 9010  nero opaco matt black  bronzo ramato coppery bronze  Metallo Metal	no none	096015
				096030
				096023
0,5 m/s    CE    F    energy saving    PG    IP20    DIM    Peso netto: 0.2 Kg <b>Confezione Packaging</b> Peso lordo: 0.28 Kg    n. Colli: 1    Volume m³: 0.002 Weight net:    Weight gross:    n. Pack:				

## A-Tube Small Ceiling | Plafoniera

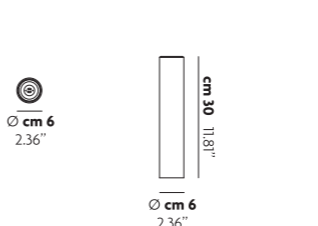
[PL3] 	GU10 Par 16 1x max 40W eco  or  GU10 Par 16 LED 1x max available [L max cm 9]  Lampadine non include Bulbs not included	bianco opaco 9010 matt white 9010  nero opaco matt black  bronzo ramato coppery bronze  Metallo Metal	no none	096007
				096031
				096024
0,5 m/s    CE    F    energy saving    PG    IP20    DIM    Peso netto: 0.8 Kg <b>Confezione Packaging</b> Peso lordo: 1.03 Kg    n. Colli: 1    Volume m³: 0.004 Weight net:    Weight gross:    n. Pack:				

## A-Tube Medium Ceiling | Plafoniera

[PL4] 	GU10 Par 16 1x max 40W eco  or  GU10 Par 16 LED 1x max available [L max cm 9]  Lampadine non include Bulbs not included	bianco opaco 9010 matt white 9010  nero opaco matt black  bronzo ramato coppery bronze  Metallo Metal	no none	096011
				096033
				096025
0,5 m/s    CE    F    energy saving    PG    IP20    DIM    Peso netto: 0.9 Kg <b>Confezione Packaging</b> Peso lordo: 1.5 Kg    n. Colli: 1    Volume m³: 0.017 Weight net:    Weight gross:    n. Pack:				

## A-Tube Large Ceiling | Plafoniera

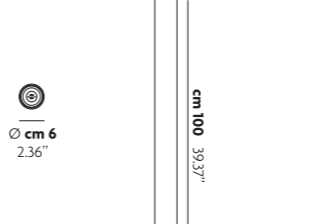
[PL5] 	GU10 Par 16 1x max 40W eco  or  GU10 Par 16 LED 1x max available [L max cm 9]  Lampadine non include Bulbs not included	bianco opaco 9010 matt white 9010  nero opaco matt black  bronzo ramato coppery bronze  Metallo Metal	no none	096013
				096035
				096026
0,5 m/s    CE    F    energy saving    PG    IP20    DIM    Peso netto: 1.5 Kg <b>Confezione Packaging</b> Peso lordo: 2.3 Kg    n. Colli: 1    Volume m³: 0.028 Weight net:    Weight gross:    n. Pack:				

Note | Notes: .....

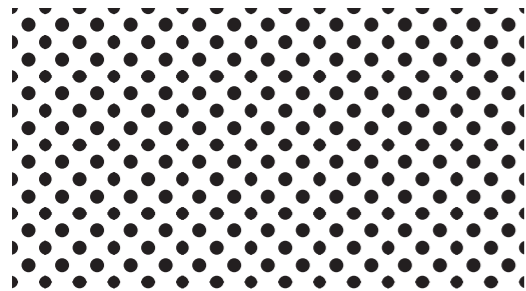
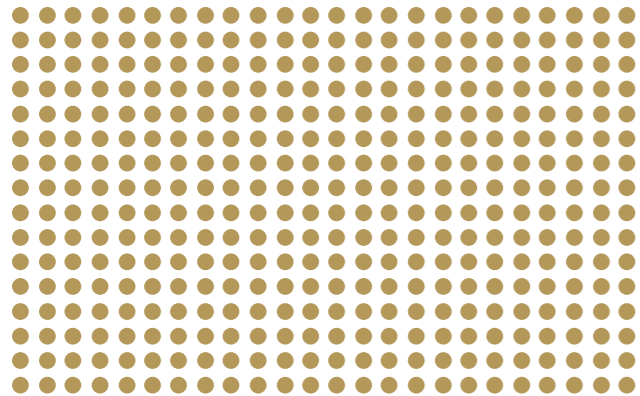

---

## PUZZLE

---

design: Studio Italia Design 2014

---

LAMPADE CHE SCOMPAIONO NEI NOSTRI SOFFITTI E NELLE NOSTRE PARETI LASCIANDO SPAZIO ALLA LUCE CON I SUOI GIOCHI E I SUOI CAPRICCI DANDO FORMA A SUGGESTIVI GIOCHI DI LUCE.

LIGHTS FITTINGS THAT DISAPPEAR IN OUR CEILINGS AND WALLS AND GIVE SPACE TO A LIGHT THAT, WITH ITS PLAYS AND WHIMS, GIVES SHAPE TO ENCHANTING LIGHTING EFFECTS.





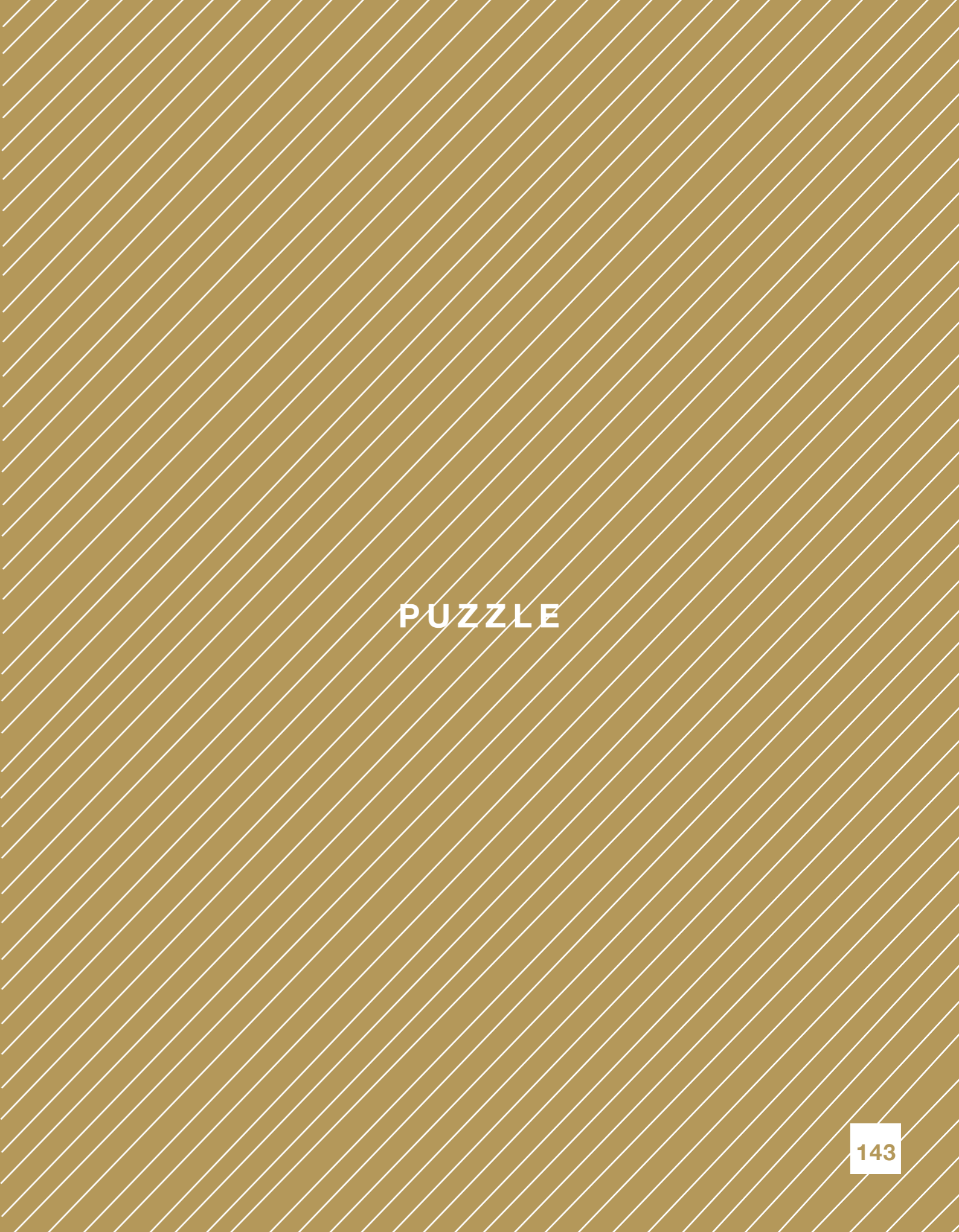

PUZZLE

PUZZLE  
STUDIO  
ITALIA  
DESIGN



---

## PUZZLE

---





# PUZZLE

MODELLO | MODEL LAMPADINA | LAMP MONTATURA | FRAME DIFFUSORE | DIFFUSER CODICE | CODE

## Puzzle Single Square Wall & Ceiling | Parete & Plafoniera

[AP3-PL3] [AP7-PL7]		<b>AP7-PL7 2700K</b> 17W   1700 lm <b>LED</b> 210-250V CRI 92 MacAdam 3-Step or <b>AP3-PL3 3000K</b> 17W   1800 lm <b>LED</b> 210-250V CRI 92 MacAdam 3-Step LED included	bianco opaco 9016 matt white 9016	no none	146008 146004
0,5 m <sup>3</sup> CE Energy saving PG ip 20 DIM TRIAC		Peso netto: 1.16 Kg Weight net:	<b>Confezione Packaging</b>	Peso lordo: 1.67 Kg Weight gross:	n. Colli: 1 n. Pack: Volume m <sup>3</sup> : 0.03 Volume m <sup>3</sup> :

## Puzzle Double Square Wall & Ceiling | Parete & Plafoniera

[AP2-PL2] [AP6-PL6]		<b>AP6-PL6 2700K</b> 2x17W   3400 lm <b>LED</b> 210-250V CRI 92 MacAdam 3-Step or <b>AP2-PL2 3000K</b> 2x17W   3600 lm <b>LED</b> 210-250V CRI 92 MacAdam 3-Step LED included	bianco opaco 9016 matt white 9016	no none	146007 146003
0,5 m <sup>3</sup> CE Energy saving PG ip 20 DIM TRIAC		Peso netto: 2 Kg Weight net:	<b>Confezione Packaging</b>	Peso lordo: 2.68 Kg Weight gross:	n. Colli: 1 n. Pack: Volume m <sup>3</sup> : 0.015 Volume m <sup>3</sup> :

## Puzzle Square & Rectangle Wall & Ceiling | Parete & Plafoniera

[AP1-PL1] [AP5-PL5]		<b>AP5-PL5 2700K</b> 2x17W   3400 lm <b>LED</b> 210-250V CRI 92 MacAdam 3-Step or <b>AP1-PL1 3000K</b> 2x17W   3600 lm <b>LED</b> 210-250V CRI 92 MacAdam 3-Step LED included	bianco opaco 9016 matt white 9016	no none	146006 146002
0,5 m <sup>3</sup> CE Energy saving PG ip 20 DIM TRIAC		Peso netto: 2.85 Kg Weight net:	<b>Confezione Packaging</b>	Peso lordo: 3.64 Kg Weight gross:	n. Colli: 1 n. Pack: Volume m <sup>3</sup> : 0.021 Volume m <sup>3</sup> :

## Puzzle Double Rectangle Wall & Ceiling | Parete & Plafoniera

[AP-PL] [AP4-PL4]		<b>AP4-PL4 2700K</b> 2x17W   3400 lm <b>LED</b> 210-250V CRI 92 MacAdam 3-Step or <b>AP-PL 3000K</b> 2x17W   3600 lm <b>LED</b> 210-250V CRI 92 MacAdam 3-Step LED included	bianco opaco 9016 matt white 9016	no none	146005 146001
0,5 m <sup>3</sup> CE Energy saving PG ip 20 DIM TRIAC		Peso netto: 3.69 Kg Weight net:	<b>Confezione Packaging</b>	Peso lordo: 4.61 Kg Weight gross:	n. Colli: 1 n. Pack: Volume m <sup>3</sup> : 0.028 Volume m <sup>3</sup> :

Note | Notes: LED con alimentazione diretta a tensione di rete (non necessita di driver LED). Dimmerabile con varialuce a taglio di fase.  
 LED with direct power supply to the AC line voltage (LED driver not required). Dimmable with phase cut dimming.

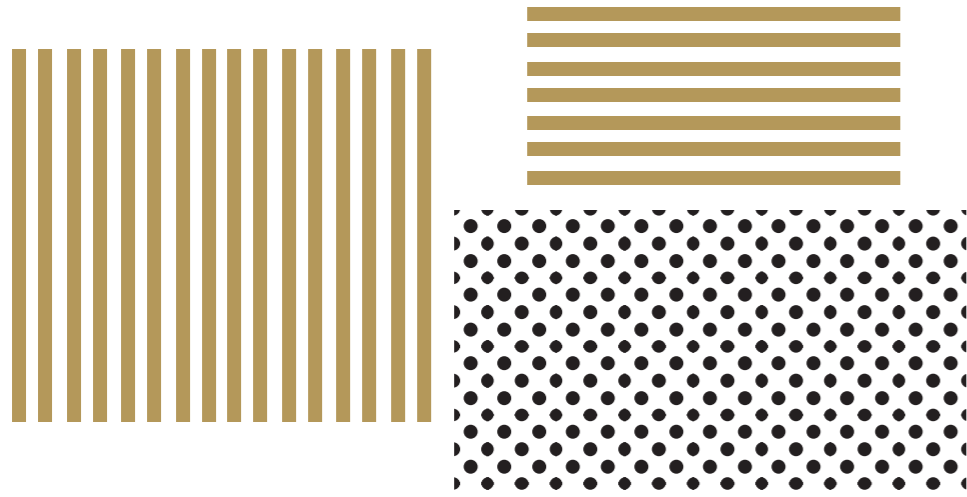

---

## PUZZLE TWIST

---

design: Studio Italia Design 2014

---

DESIGN TECNICO, ESSENZIALE E RICERCATO DONA ALL'ILLUMINAZIONE LA PARTE DA PROTAGONISTA FORMANDO SUGGESTIVI E MAGICI GIOCHI DI LUCE.

TECHNICAL, ESSENTIAL AND REFINED DESIGN GIVES THE LIGHT THE ROLE OF MAIN CHARACTER CREATING MAGICAL AND SUGGESTIVE LIGHTING EFFECTS.



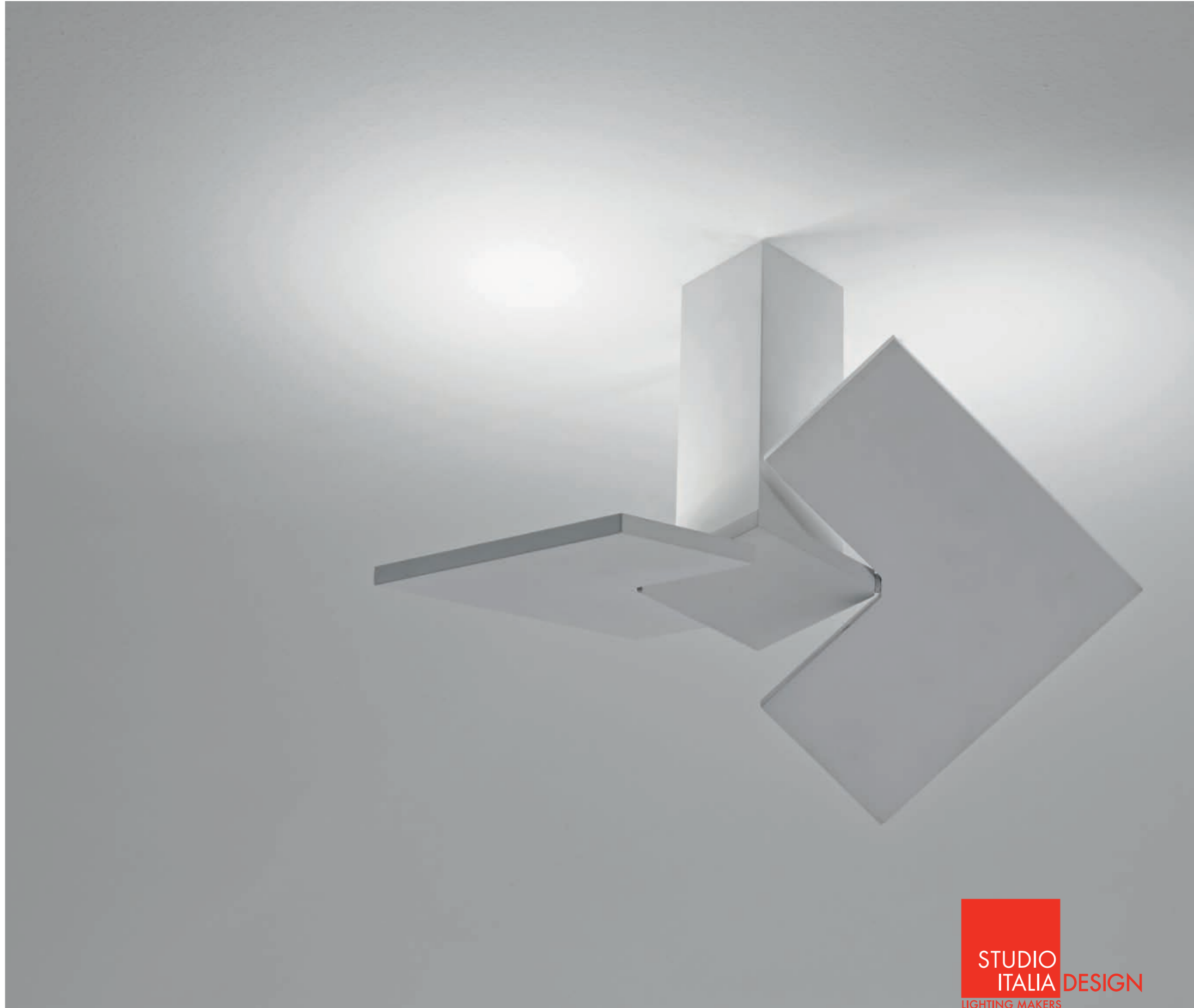

PUZZLE  
TWIST  
STUDIO  
ITALIA  
DESIGN





# PUZZLE TWIST

MODELLO | MODEL      LAMPADINA | LAMP      MONTATURA | FRAME      DIFFUSORE | DIFFUSER      CODICE | CODE

## Puzzle Twist Wall | Parete

<p>[AP-AP1]</p>	<p>AP <b>2700K</b> 17W   1700 lm <b>LED</b> 210-250V CRI 92 MacAdam 3-Step</p>	<p>○ bianco opaco 9016 matt white 9016</p>	<p><math>\frac{\text{no}}{\text{none}}</math></p>	146009	
	<p>or</p> <p>API <b>3000K</b> 17W   1800 lm <b>LED</b> 210-250V CRI 92 MacAdam 3-Step</p>			146010	
<p><b>LED</b> included</p>		<p>Metallo Metal</p>			
<p>0,5 m<sup>2</sup> CE Energy saving PG IP20 DIM TRIAC</p>		<p>Peso netto: 0.88 Kg <b>Confezione Packaging</b></p>	<p>Peso lordo: 1.39 Kg</p>	<p>n. Colli: 1 n. Pack: 1</p>	<p>Volume m<sup>3</sup>: 0.013 Volume m<sup>3</sup>: 0.013</p>

## Puzzle Twist Ceiling | Plafoniera

<p>[PL-PL1]</p>	<p>PL <b>2700K</b> 2x17W   3400 lm <b>LED</b> 210-250V CRI 92 MacAdam 3-Step</p>	<p>○ bianco opaco 9016 matt white 9016</p>	<p><math>\frac{\text{no}}{\text{none}}</math></p>	146011	
	<p>or</p> <p>PL1 <b>3000K</b> 2x17W   3600 lm <b>LED</b> 210-250V CRI 92 MacAdam 3-Step</p>			146012	
<p><b>LED</b> included</p>		<p>Metallo Metal</p>			
<p>0,5 m<sup>2</sup> CE Energy saving PG IP20 DIM TRIAC</p>		<p>Peso netto: 2.47 Kg <b>Confezione Packaging</b></p>	<p>Peso lordo: 3.28 Kg</p>	<p>n. Colli: 1 n. Pack: 1</p>	<p>Volume m<sup>3</sup>: 0.031 Volume m<sup>3</sup>: 0.031</p>

## Puzzle Twist Floor | Terra

<p>[LT-LT1]</p>	<p>LT <b>2700K</b> 2x17W   3400 lm <b>LED</b> 210-250V CRI 92 MacAdam 3-Step</p>	<p>○ bianco opaco 9016 matt white 9016</p>	<p><math>\frac{\text{no}}{\text{none}}</math></p>	146014	
	<p>or</p> <p>LT1 <b>3000K</b> 2x17W   3600 lm <b>LED</b> 210-250V CRI 92 MacAdam 3-Step</p>			146015	
<p><b>LED</b> included</p>		<p>Metallo Metal</p>			
<p>0,5 m<sup>2</sup> CE Energy saving PG IP20 DIM TRIAC included</p>		<p>Peso netto: 7.5 Kg <b>Confezione Packaging</b></p>	<p>Peso lordo: 12.8 Kg</p>	<p>n. Colli: 1 n. Pack: 1</p>	<p>Volume m<sup>3</sup>: 0.328 Volume m<sup>3</sup>: 0.328</p>

THE  
LIGHTING  
MAKERS  
2017

Note | Notes: LED con alimentazione diretta a tensione di rete (non necessita di driver LED). Dimmerabile con varialuce a taglio di fase.  
LED with direct power supply to the AC line voltage (LED driver not required). Dimmable with phase cut dimming.



---

## PUZZLE ROUND

---

design: Studio Italia Design 2016

---

PER CHI PREDILIGE LE FORME MORBIDE ABBIAMO RICREATO LA NOSTRA PUZZLE SENZA SPIGOLI, ESALTANDOLA CON LA POSSIBILITÀ DI GIOCARE CON GLI EFFETTI LUMINOSI.

FOR THOSE WHO PREFER ROUND SHAPES, WE HAVE RECREATED OUR BEST SELLING PUZZLE RANGE WITHOUT SHARP EDGES, IMPROVING THE NUMERABLE LIGHTING EFFECTS THAT CAN BE CREATED.













# PUZZLE ROUND



MODELLO | MODEL      LAMPADINA | LAMP      MONTATURA | FRAME      DIFFUSORE | DIFFUSER      CODICE | CODE

## Puzzle Single Round Wall | Parete

[AP-AP1] 	AP <b>2700K</b> 17W   1700 lm <b>LED</b> 210-250V CRI 92 MacAdam 3-Step	○ bianco opaco 9016 matt white 9016 ● bronzo ramato coppery bronze	no none	159001	
	or AP1 <b>3000K</b> 17W   1800 lm <b>LED</b> 210-250V CRI 92 MacAdam 3-Step LED included	○ bianco opaco 9016 matt white 9016 ● bronzo ramato coppery bronze Metallo Metal		159007	
0,5 m <sup>2</sup> CE Energy saving PG ip20 DIM TRIAC		Peso netto: 0,6 Kg Weight net:	Confezione Packaging Peso lordo: 0,92 Kg Weight gross:	n. Colli: 1 n. Pack:	Volume m <sup>3</sup> : 0,013 Volume m <sup>3</sup> :

## Puzzle Double Round Wall & Ceiling | Parete & Plafoniera

[AP2-PL2] [AP3-PL3] 	AP2-PL2 <b>2700K</b> 2x17W   3400 lm <b>LED</b> 210-250V CRI 92 MacAdam 3-Step	○ bianco opaco 9016 matt white 9016 ● bronzo ramato coppery bronze	no none	159003	
	or AP3-PL3 <b>3000K</b> 2x17W   3600 lm <b>LED</b> 210-250V CRI 92 MacAdam 3-Step LED included	○ bianco opaco 9016 matt white 9016 ● bronzo ramato coppery bronze Metallo Metal		159008	
0,5 m <sup>2</sup> CE Energy saving PG ip20 DIM TRIAC		Peso netto: 1,1 Kg Weight net:	Confezione Packaging Peso lordo: 1,54 Kg Weight gross:	n. Colli: 1 n. Pack:	Volume m <sup>3</sup> : 0,023 Volume m <sup>3</sup> :



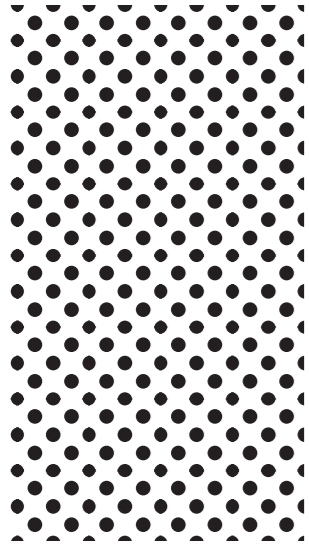

---

## LASER CUBE

design: Studio Italia Design 2004/2015

---

STRUTTURA IN METALLO ELEGANTE E RAFFINATA CHE RIPRODUCE ESATTAMENTE LE FATTEZZE DI UN CUBO AL CUI INTERNO LA SUA ANIMA LED PERMETTE DI SPRIGIONARE FASCI DI LUCE INDIRECTA ORIENTATA SIA VERSO L'ALTO CHE VERSO IL BASSO CREANDO MAGNIFICI EFFETTI LUMINOSI CHE AFFASCINANO E VALORIZZANO L'AMBIENTE.

AN ELEGANT AND POLISHED STRUCTURE IN METAL REPRODUCES A PERFECT CUBE, IT'S LED INNER SOUL ALLOWS LIGHT EFFECTS TO SPREADS INDIRECTLY, UP AND DOWN, FASCINATING AND ENHANCING IT'S SURROUNDING SPACES .



# LASER



MODELLO | MODEL      LAMPADINA | LAMP      MONTATURA | FRAME      DIFFUSORE | DIFFUSER      CODICE | CODE

## Laser 10x6 Led Wall | Parete

[AP8-AP10]  	AP10 <b>2700K</b> 9W   900 lm <b>LED</b> 210-250V CRI 92 MacAdam 3-Step	○ bianco opaco 9010 matt white 9010  ● nero opaco matt black  ● bronzo ramato coppery bronze	no none	036027  036032  036028
	or  AP8 <b>3000K</b> 9W   950 lm <b>LED</b> 210-250V CRI 92 MacAdam 3-Step	○ bianco opaco 9010 matt white 9010  ● nero opaco matt black  ● bronzo ramato coppery bronze		036023  036031  036024
LED included      Metallo Metal		Peso netto: 0.5 Kg <b>Confezione Packaging</b> Peso lordo: 0.62 Kg      n. Colli: 1      Volume m³: 0.002 Weight net:      Weight gross:      n. Pack:		

## Laser 10x10 Led Wall | Parete

[AP9-AP11]  	AP11 <b>2700K</b> 17W   1700 lm <b>LED</b> 210-250V CRI 92 MacAdam 3-Step	○ bianco opaco 9010 matt white 9010  ● nero opaco matt black  ● bronzo ramato coppery bronze	no none	036029  036034  036030
	or  AP9 <b>3000K</b> 17W   1800 lm <b>LED</b> 210-250V CRI 92 MacAdam 3-Step	○ bianco opaco 9010 matt white 9010  ● nero opaco matt black  ● bronzo ramato coppery bronze		036025  036033  036026
LED included      Metallo Metal		Peso netto: 0.6 Kg <b>Confezione Packaging</b> Peso lordo: 0.85 Kg      n. Colli: 1      Volume m³: 0.007 Weight net:      Weight gross:      n. Pack:		

Note | Notes: LED con alimentazione diretta a tensione di rete (non necessita di driver LED). Dimmerabile con varialuce a taglio di fase.  
 LED with direct power supply to the AC line voltage (LED driver not required). Dimmable with phase cut dimming.

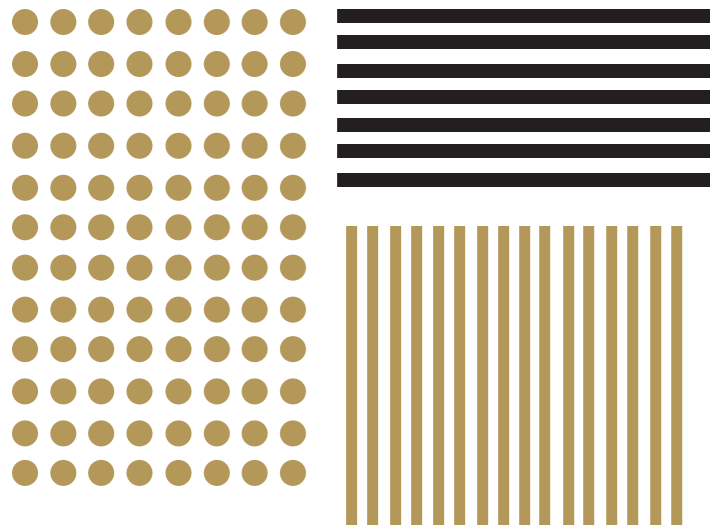

---

# THOR

design: Andrea Tosetto 2015

---

IL PIACERE DI GOVERNARE LA LUCE PROPRIO COME UN DIO MITOLOGICO, PASSANDO DA UN'ECLISSI AD UNA LUNA PIENA. AGENDO SULLA STRUTTURA STESSA SI POSSONO RICREARE CENTINAIA DI SITUAZIONI LUMINOSE DIFFERENTI.

THE PLEASURE OF RULING LIGHT JUST LIKE A MYTHOLOGICAL GOD, GOING FROM AN ECLIPSE TO A FULL MOON EFFECT. BY ACTING ON THE STRUCTURE ITSELF IT IS POSSIBLE TO CREATE HUNDREDS OF DIFFERENT LIGHT EFFECTS.





THE  
LIGHTING  
MAKERS  
2017

THOR  
STUDIO  
ITALIA  
DESIGN





MODELLO | MODEL

LAMPADINA | LAMP

MONTATURA | FRAME

DIFFUSORE | DIFFUSER

CODICE | CODE

**Thor Small** Wall & Ceiling | Parete & Plafoniera

<p>[AP1-PL1]</p>	<p><b>3000K</b> 17W   1800 lm <b>LED</b> 210-250V CRI 92 MacAdam 3-Step</p> <p><b>LED</b> included</p>	<p>bianco opaco 9010 matt white 9010</p> <p>Metallo Metal</p>	<p>bianco latte lucido glossy milk white</p> <p>Polycarbonato Polycarbonate</p>	<p>152002</p>
<p>0,5 m<sup>2</sup> CE Energy saving PG ip40 DIM TRIAC</p>		<p>Peso netto: 1.45 Kg Weight net:</p>	<p><b>Confezione Packaging</b> Peso lordo: 1.99 Kg Weight gross:</p>	<p>n. Colli: 1 n. Pack: 1 Volume m<sup>3</sup>: 0.026</p>

**Thor Medium** Wall & Ceiling | Parete & Plafoniera

<p>[AP-PL]</p>	<p><b>3000K</b> 2x17W   3600 lm <b>LED</b> 210-250V CRI 92 MacAdam 3-Step</p> <p><b>LED</b> included</p>	<p>bianco opaco 9010 matt white 9010</p> <p>Metallo Metal</p>	<p>bianco latte lucido glossy milk white</p> <p>Polycarbonato Polycarbonate</p>	<p>152001</p>
<p>0,5 m<sup>2</sup> CE Energy saving PG ip40 DIM TRIAC</p>		<p>Peso netto: 3.7 Kg Weight net:</p>	<p><b>Confezione Packaging</b> Peso lordo: 5.55 Kg Weight gross:</p>	<p>n. Colli: 1 n. Pack: 1 Volume m<sup>3</sup>: 0.115</p>

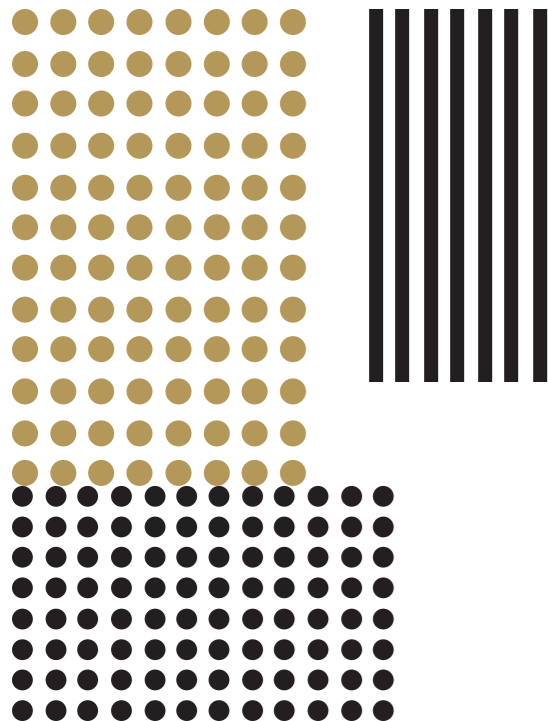

---

## SUGEGASA

design: Andrea Tosetto 2017

---

LA PERFEZIONE NELLA SEMPLICITÀ DELLE COSE. L'ARMONIA E L'EQUILIBRIO DELLE LINEE SEMPLICI E LEGGEREZZA DEL POLICARBONATO VENGONO COMBinate DA UNA SUPERFICIE PREZIOSA RENDENDOLA AFFASCINANTE SIA QUANDO È ILLUMINATA SIA QUANDO È SPENTA.

PERFECTION IS IN THE SIMPLICITY OF THINGS. THE HARMONY AND THE BALANCE OF SIMPLE LINES AND THE ETHEREAL LIGHTNESS OF POLYCARBONATE ARE COMBINED ON A PRECIOUS SURFACE THAT MAKE THE RANGE ENCHANTING BOTH WITH THE LIGHT ON AND OFF.







SUGE-  
GASA



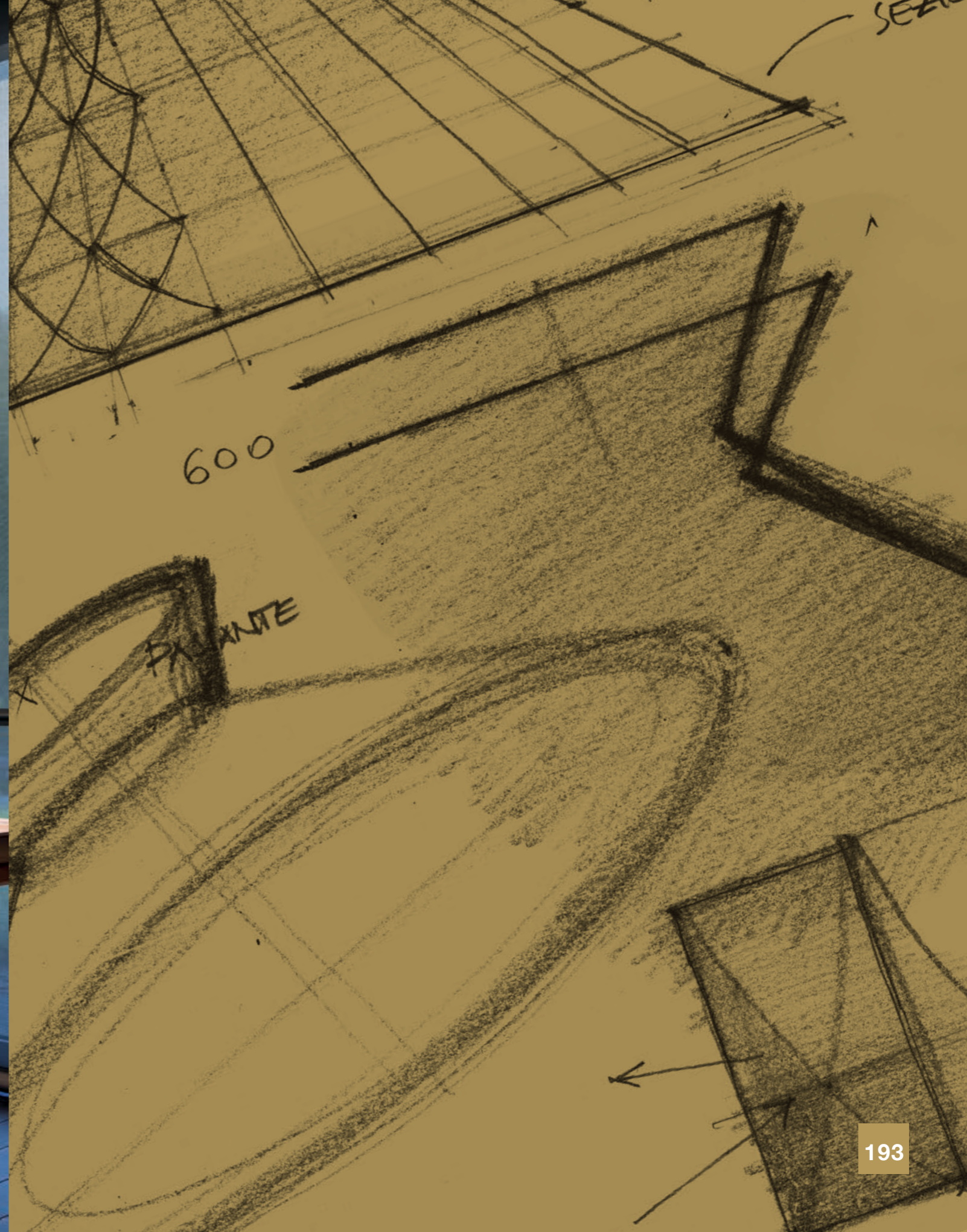

SUGEGASA  
STUDIO  
ITALIA  
DESIGN

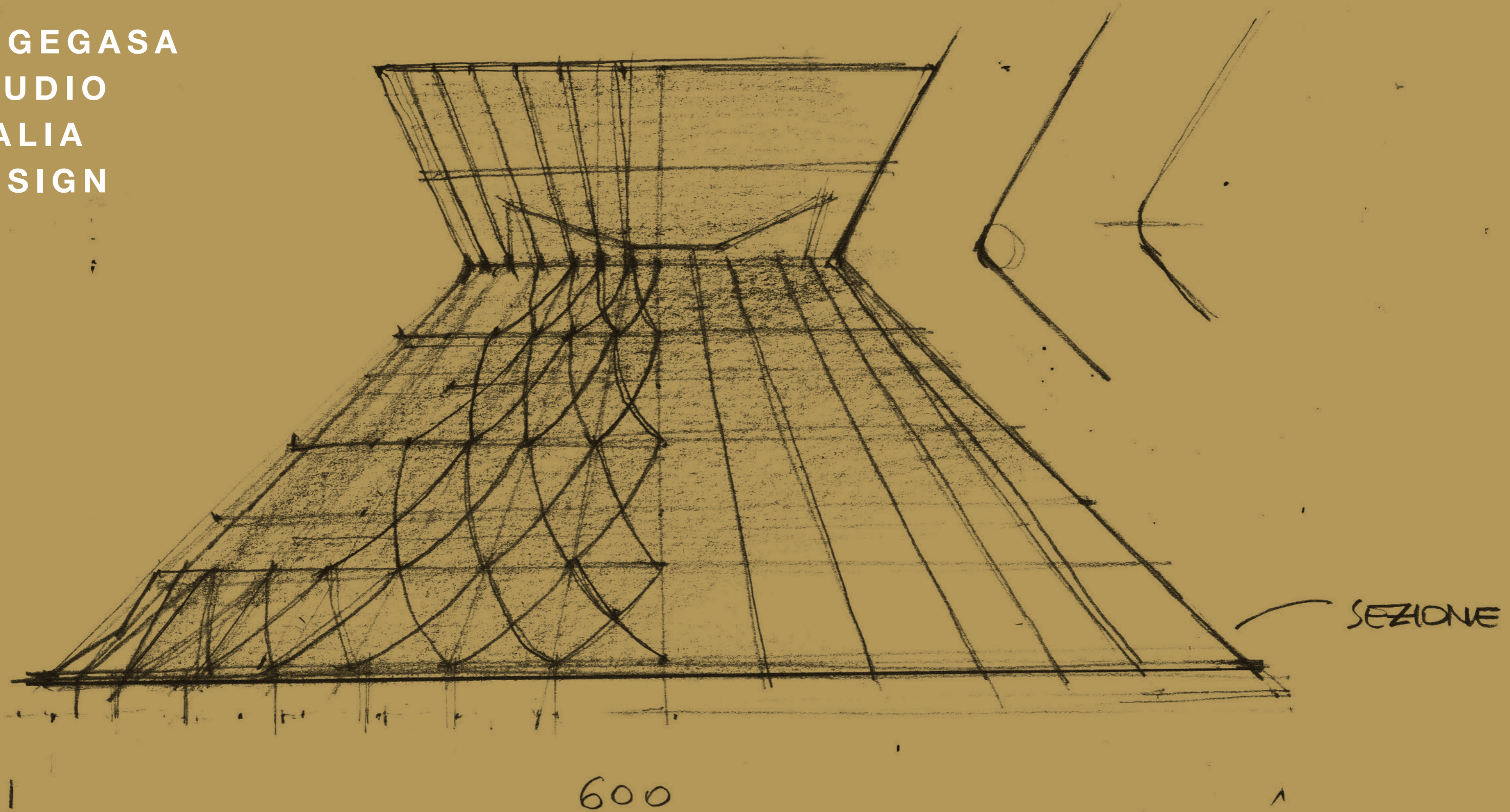

X DETAGLIO D  
SELA 1:2 X

FASCIANTE



# SUGEGASA

MODELLO | MODEL

LAMPADINA | LAMP

MONTATURA | FRAME

DIFFUSORE | DIFFUSER

CODICE | CODE

## Sugegasa Pendant | Sospensione

<p>[SO]</p> <p>Ø cm 60 23.62"</p> <p>Ø cm 8 3.15"</p> <p>max cm 400 157.48"</p> <p>cm 29 11.41"</p>	<p>E27 G95 LED 1x max available</p> <p>or</p> <p>E27 G95 CFL 1x max available</p>	<p>○ cromo chrome</p>	<p>○ cristallo crystal</p> <p>○ fumé trasparente clear fumé</p> <p>○ rosé trasparente clear rosé</p> <p>○ azzurro trasparente clear azure</p>	<p>163001</p> <p>163002</p> <p>163003</p> <p>163004</p>
<p>Lampadine non incluse Bulbs not included</p>	<p>Metallo Metal</p>	<p>Polimetilmetacrilato PMMA</p>	<p>Peso netto: 2.5 Kg Weight net: 2.5 Kg</p>	<p><b>Confezione Packaging</b></p> <p>Peso lordo: ---- Kg Weight gross: ---- Kg</p> <p>n. Colli: 1 n. Pack: 1</p> <p>Volume m³: ---- Volume m³: ----</p>

0,5 m³ CE Energy saving PG ip20 DIM

Note | Notes: .....

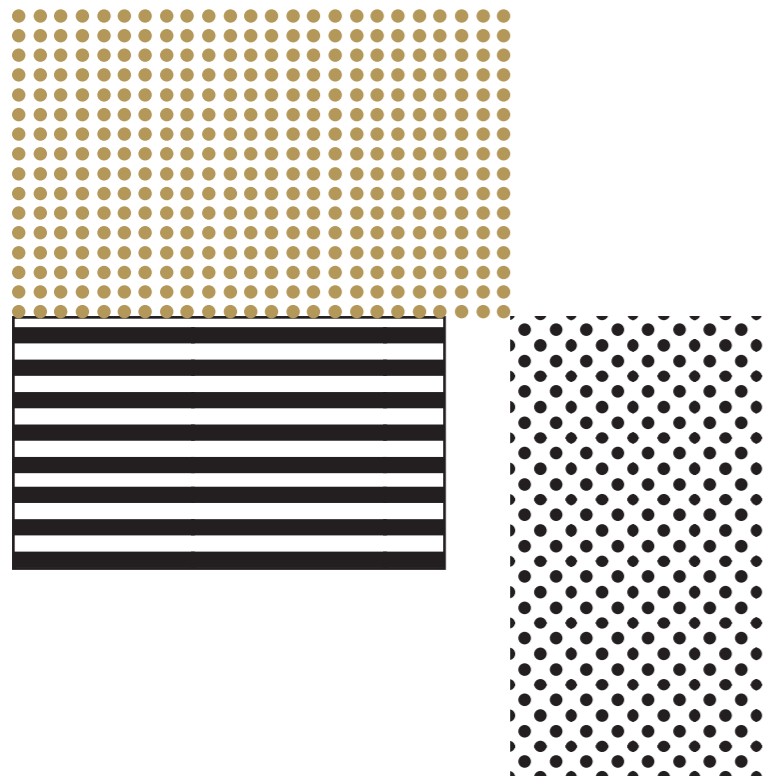

---

## KELLY

design: Andrea Tosetto 2015

---

SEDUCENTE BELLEZZA INTRISA DI CARATTERE GRAZIE AI TAGLI A LASER DECISI E PRECISI, I QUALI CREANO GIOCHI DI LUCE ED OMBRE INTRIGANTI E PREZIOSI. CON IL SUO DESIGN SEMPLICE E SENZA TEMPO È GIÀ DIVENTATA UN MUST DI STUDIO ITALIA DESIGN.

SEDUCTIVE BEAUTY WITH CHARACTER THANKS TO A PERFECT LASER CUT, CREATING INTRIGUING AND PRECIOUS LIGHT EFFECTS AND SHADOWS. WITH IT'S SIMPLE AND TIMELESS DESIGN IT HAS ALREADY BECOME A DESIGN CLASSIC FOR STUDIO ITALIA DESIGN.



# KELLY BLACK















---

# KELLY

---







KELLY  
STUDIO  
ITALIA  
DESIGN



---

**KELLY**

---



# KELLY

MODELLO | MODEL LAMPADINA | LAMP MONTATURA | FRAME DIFFUSORE | DIFFUSER CODICE | CODE

## Kelly Wall | Parete

[AP]		<b>2700K</b> 17W   1700 lm 210-250V CRI 92 MacAdam 3-Step <b>LED</b> included	bianco opaco 9010 matt white 9010  bronzo ramato coppery bronze	no none	141011  141012	
		Peso netto: 0.8 Kg Weight net:	<b>Confezione Packaging</b>	Peso lordo: 1.13 Kg Weight gross:	n. Colli: 1 n. Pack:	Volume m <sup>3</sup> : 0.016 Volume m <sup>3</sup> :

## Kelly Small Dome 50 Pendant | Sospensione

[SO1]		E27 Classic A60 3x max 46W eco or E27 CFL [compact] 3x max 23W [L max cm 12] or E27 LED 3x max available [L max cm 12] Lampadine non include Bulbs not included	bianco opaco 9010 matt white 9010  nero opaco matt black  bronzo ramato coppery bronze	bianco latte lucido glossy milk white	141002  141016  141009	
		Peso netto: 6 Kg Weight net:	<b>Confezione Packaging</b>	Peso lordo: 10.04 Kg Weight gross:	n. Colli: 1 n. Pack:	Volume m <sup>3</sup> : 0.16 Volume m <sup>3</sup> :

## Kelly Medium Dome 60 Pendant | Sospensione

[SO5]		E27 Classic A60 3x max 46W eco or E27 CFL [compact] 3x max 23W [L max cm 12] or E27 LED 3x max available [L max cm 12] Lampadine non include Bulbs not included	bianco opaco 9010 matt white 9010  nero opaco matt black  bronzo ramato coppery bronze	bianco latte lucido glossy milk white	141013  141018  141014	
		Peso netto: 7.15 Kg Weight net:	<b>Confezione Packaging</b>	Peso lordo: 13.08 Kg Weight gross:	n. Colli: 1 n. Pack:	Volume m <sup>3</sup> : 0.245 Volume m <sup>3</sup> :

## Kelly Large Dome 80 Pendant | Sospensione

[SO]		E27 Classic A60 4x max 46W eco or E27 CFL [compact] 4x max 23W [L max cm 12] or E27 LED 4x max available [L max cm 12] Lampadine non include Bulbs not included	bianco opaco 9010 matt white 9010  nero opaco matt black  bronzo ramato coppery bronze	bianco latte lucido glossy milk white	141001  141017  141010	
		Peso netto: 11 Kg Weight net:	<b>Confezione Packaging</b>	Peso lordo: 22 Kg Weight gross:	n. Colli: 1 n. Pack:	Volume m <sup>3</sup> : 0.53 Volume m <sup>3</sup> :

Note | Notes: **Kelly Wall** - LED con alimentazione diretta a tensione di rete (non necessita di driver LED). Dimmerabile con variatore a taglio di fase.  
**Kelly Wall** - LED with direct power supply to the AC line voltage (LED driver not required). Dimmable with phase cut dimming.

# KELLY

MODELLO | MODEL LAMPADINA | LAMP MONTATURA | FRAME DIFFUSORE | DIFFUSER CODICE | CODE

## Kelly Small Sphere 40 Pendant | Sospensione

[SO2]		E27 Classic A60 3x max 46W eco or E27 CFL [compact] 3x max 23W [L max cm 12] or E27 LED 3x max available [L max cm 12] Lampadine non include Bulbs not included	bianco opaco 9010 matt white 9010  bronzo ramato coppery bronze	bianco latte lucido glossy milk white	141003  141250	
		Peso netto: 5.5 Kg Weight net:	<b>Confezione Packaging</b>	Peso lordo: 8.36 Kg Weight gross:	n. Colli: 2 n. Pack:	Volume m <sup>3</sup> : 0.16 Volume m <sup>3</sup> :

## Kelly Medium Sphere 50 Pendant | Sospensione

[SO3]		E27 Classic A60 3x max 46W eco or E27 CFL [compact] 3x max 23W [L max cm 12] or E27 LED 3x max available [L max cm 12] Lampadine non include Bulbs not included	bianco opaco 9010 matt white 9010  bronzo ramato coppery bronze	bianco latte lucido glossy milk white	141004  141269	
		Peso netto: 9 Kg Weight net:	<b>Confezione Packaging</b>	Peso lordo: 14.45 Kg Weight gross:	n. Colli: 2 n. Pack:	Volume m <sup>3</sup> : 0.289 Volume m <sup>3</sup> :

## Kelly Large Sphere 80 Pendant | Sospensione

[SO4]		E27 Classic A60 4x max 46W eco or E27 CFL [compact] 4x max 23W [L max cm 12] or E27 LED 4x max available [L max cm 12] Lampadine non include Bulbs not included	bianco opaco 9010 matt white 9010  bronzo ramato coppery bronze	bianco latte lucido glossy milk white	141005  141270	
		Peso netto: 15 Kg Weight net:	<b>Confezione Packaging</b>	Peso lordo: 22.12 Kg Weight gross:	n. Colli: 2 n. Pack:	Volume m <sup>3</sup> : 0.672 Volume m <sup>3</sup> :

Note | Notes: .....



# KELLY

MODELLO | MODEL      LAMPADINA | LAMP      MONTATURA | FRAME      DIFFUSORE | DIFFUSER      CODICE | CODE

## Kelly Mini Sphere Standing | Appoggio

<p>[TA]</p>	<p><b>2700K</b> 9W   900 lm 210-250V CRI 92 MacAdam 3-Step</p> <p><b>LED</b> included</p>	<p>○ bianco opaco 9010 matt white 9010</p> <p>● bronzo ramato coppery bronze</p> <p>Metallo Metal</p>	<p>141006</p> <p>141015</p>
<p>0,5 m<sup>3</sup> CE energy saving PG ip 40 DIM TRIAC DIMMER not included</p> <p>Peso netto: 3 Kg    <b>Confezione Packaging</b>    Peso lordo: 3,66 Kg    n. Colli: 1    Volume m<sup>3</sup>: 0.023 Weight net:    Weight gross:    n. Pack:</p>			

## Kelly Small Sphere Standing | Appoggio

<p>[TA1]</p>	<p>E27 Classic A60 3x max 46W eco</p> <p>or</p> <p>E27 CFL [compact] 3x max 23W [L max cm 12]</p> <p>or</p> <p>E27 LED 3x max available [L max cm 12]</p> <p>Lampadine non incluse Bulbs not included</p>	<p>○ bianco opaco 9010 matt white 9010</p>	<p>○ bianco latte lucido glossy milk white</p> <p>Vetro Glass</p>	<p>141007</p>
<p>0,5 m<sup>3</sup> CE energy saving PG ip 40 DIM included</p> <p>Peso netto: 6 Kg    <b>Confezione Packaging</b>    Peso lordo: 8,86 Kg    n. Colli: 2    Volume m<sup>3</sup>: 0.16 Weight net:    Weight gross:    n. Pack:</p>				

## Kelly Large Sphere Standing | Appoggio

<p>[TA2]</p>	<p>E27 Classic A60 4x max 46W eco</p> <p>or</p> <p>E27 CFL [compact] 4x max 23W [L max cm 12]</p> <p>or</p> <p>E27 LED 4x max available [L max cm 12]</p> <p>Lampadine non incluse Bulbs not included</p>	<p>○ bianco opaco 9010 matt white 9010</p>	<p>○ bianco latte lucido glossy milk white</p> <p>Vetro Glass</p>	<p>141008</p>
<p>0,5 m<sup>3</sup> CE energy saving PG ip 40 DIM included</p> <p>Peso netto: 18 Kg    <b>Confezione Packaging</b>    Peso lordo: 25,11 Kg    n. Colli: 2    Volume m<sup>3</sup>: 0.672 Weight net:    Weight gross:    n. Pack:</p>				

THE  
LIGHTING  
MAKERS  
2017

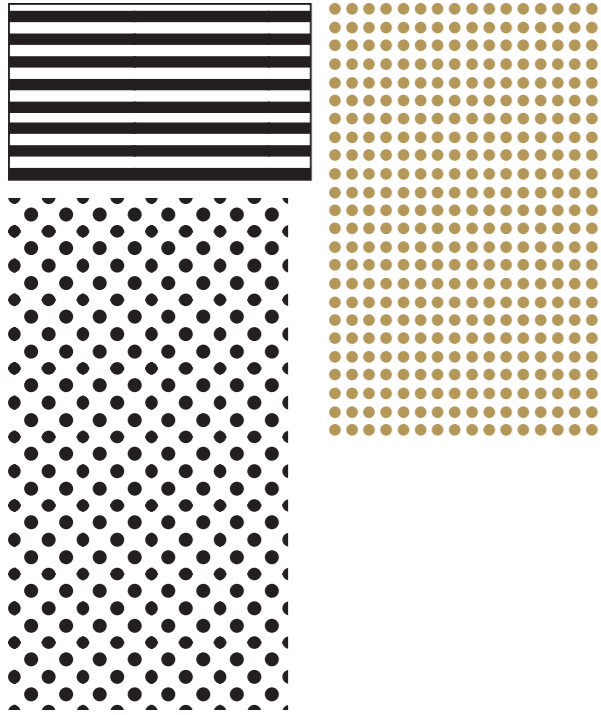

---

## KELLY CLUSTER

design: Andrea Tosetto 2015

---

NATA DA KELLY, QUESTA PICCOLA PALLINA INTAGLIATA PERMETTE DI CREARE DEI CLUSTER CAPACI DI SODDISFARE QUALSIASI TIPO DI ESIGENZA CREANDO DELLE COMPOSIZIONI AFFASCINANTI E DI GRANDE PERSONALITÀ.

AS AN OFFSHOOT OF THE KELLY, THIS SMALL SCULPTED PIECE ALLOWS YOU TO CREATE CLUSTERS ABLE TO SATISFY THE MOST DEMANDING DESIGNS BY CREATING FASCINATING COMPOSITIONS FULL OF PERSONALITY.



KELLY CLUSTER

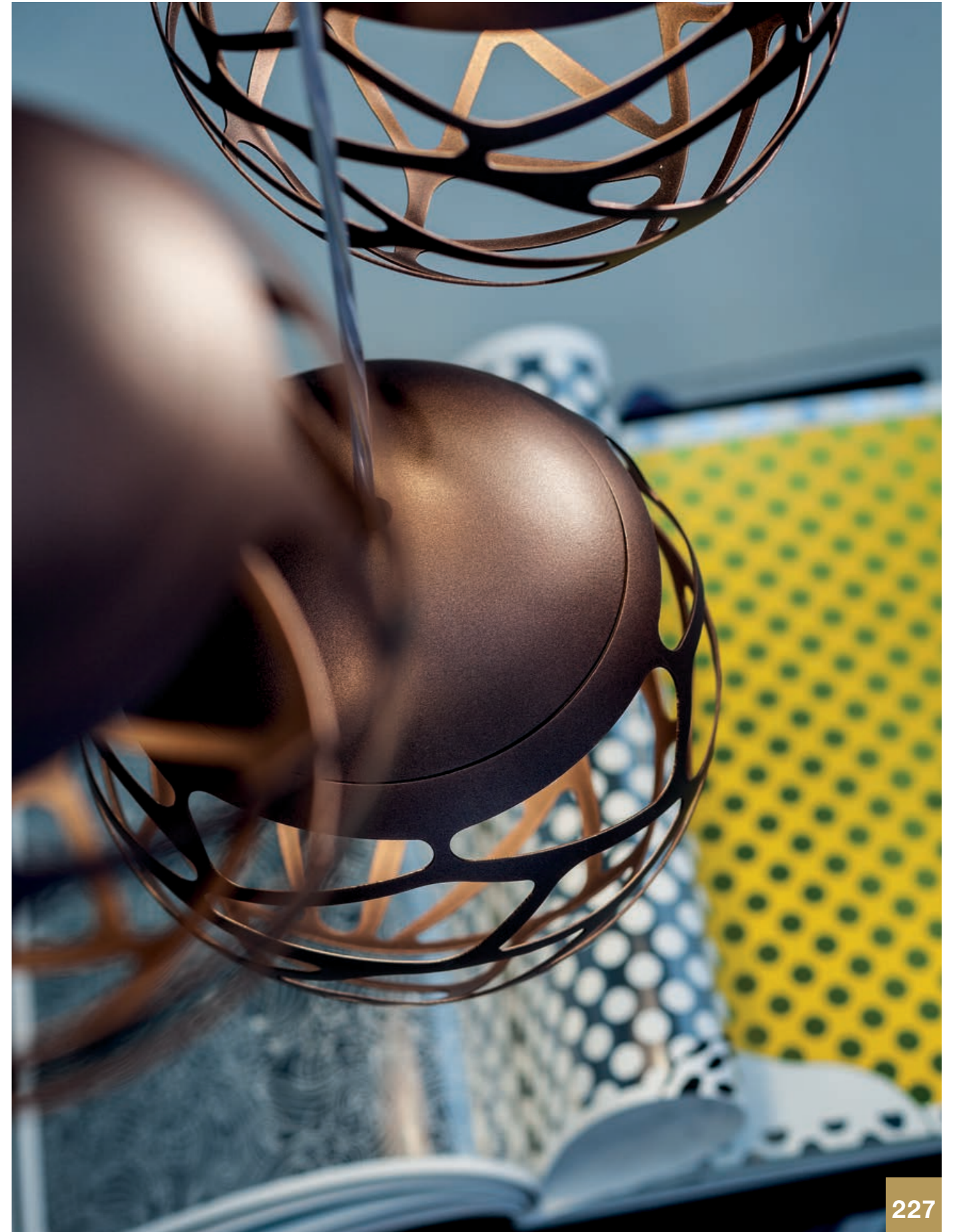



KELLY  
CLUSTER



THE  
LIGHTING  
MAKERS  
2017



KELLY  
CLU-  
STER  
BLACK



**KELLY  
CLUSTER  
STUDIO  
ITALIA  
DESIGN**

THE LIGHTING  
MAKERS  
2017





STUDIO  
ITALIA DESIGN  
LIGHTING MAKERS





# KELLY CLU- STER



# KELLY CLUSTER

## composition

### Kelly Cluster example of composition

[Ex: 1] Single Radial Suspension | Sospensione Singola Decentrata

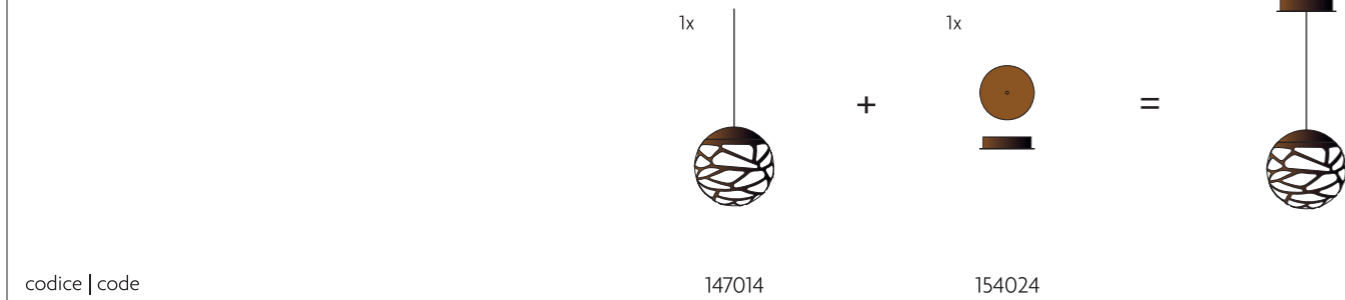

codice | code

[Ex: 2] Double Opposed Suspensions | Sospensioni Contrapposte



codice | code

[Ex: 3] Cluster 3 Lights Composition | Composizione 3 Luci

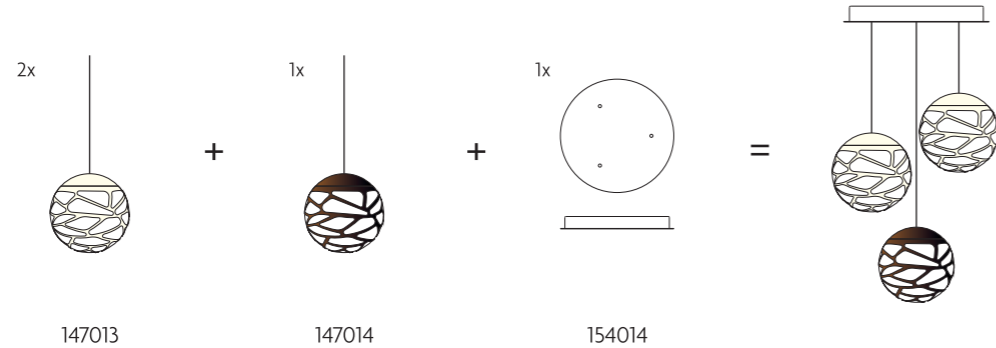

codice | code

[Ex: 4] Short Track with 4 Lights | Binario Lineare Multiplo Corto 4 Luci

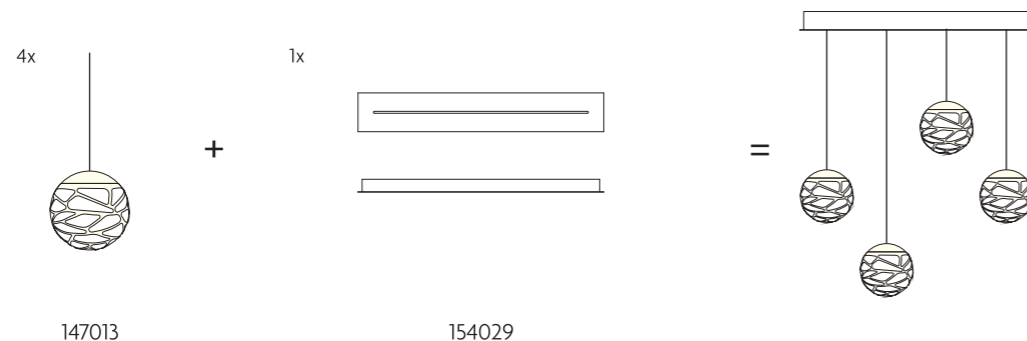

codice | code

Note | Notes: .....

# KELLY CLUSTER

MODELLO | MODEL

LAMPADINA | LAMP

MONTATURA | FRAME

DIFFUSORE | DIFFUSER

CODICE | CODE

### Kelly Cluster Sphere Pendant | Sospensione

<p>[SO]</p> <p>Ø cm 18 7.08"</p> <p>max cm 400 157.48"</p>	<p><b>LED</b></p> <p>2700K 9W   900 lm 210-250V CRI 92 MacAdam 3-Step</p>	<p>○ bianco opaco 9010 matt white 9010</p> <p>● nero opaco matt black</p> <p>● bronzo ramato coppery bronze</p>	<p>○ bianco latte lucido glossy milk white</p>	<p>147013</p> <p>147015</p> <p>147014</p>
<p>LED included</p> <p>Peso netto: 0.8 Kg Weight net:</p>		<p>Confezione Packaging</p>	<p>Metallo Metal</p> <p>Peso lordo: 1.46 Kg Weight gross:</p>	<p>Vetro Glass</p> <p>n. Colli: 1 n. Pack:</p> <p>Volume m³: 0.023 Volume m³:</p>

Le sospensioni devono essere installate sui **rosoni** presenti alle pagine 342-349  
 The pendants must be installed with one of the **canopy** options listed on page 342-349  
 Les suspensions doivent être installées sur les **patères** présentées dans les pages 342-349  
 Die Hängeleuchten sollen auf die **Rosetten** auf Seiten 342-349 montiert werden  
 Las lámparas de suspensión se deben instalar en los **rósetones** a pagina 342-349

Note | Notes: LED con alimentazione diretta a tensione di rete (non necessita di driver LED). Dimmerabile con varialuce a taglio di fase.  
 LED with direct power supply to the AC line voltage (LED driver not required). Dimmable with phase cut dimming.

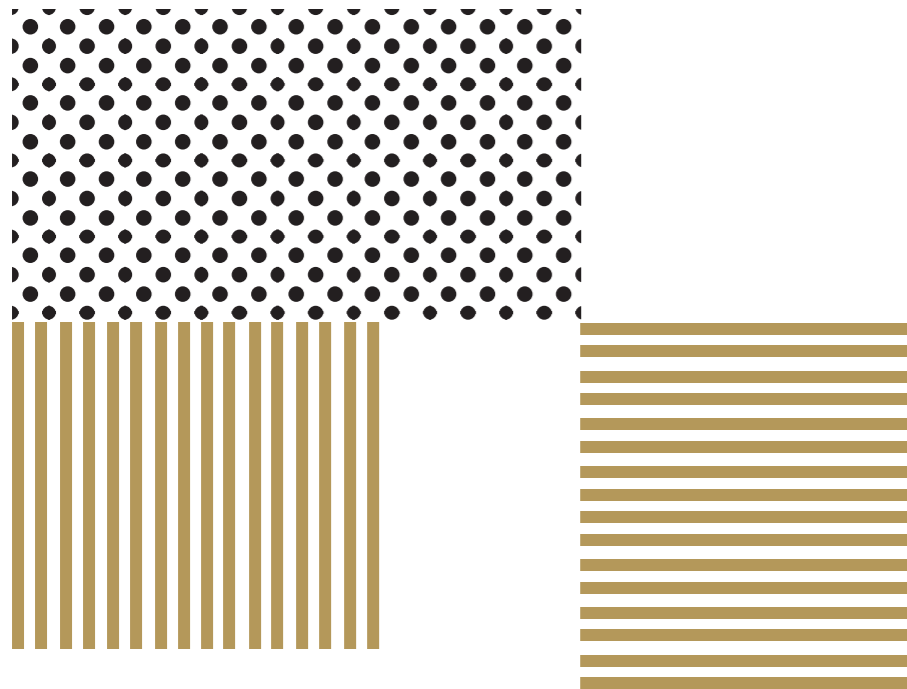

## MAGGIO

design: Marta Sansoni 2016

LE DECORAZIONI CHE SI INTERSECANO TRA LORO RICORDANO RAMI, EVOCANDO LA PRIMAVERA CON GIOCHI DI LUCE MAGICI E SUGGESTIVI. DONA AGLI INTERNI UN DESIGN ORGANICO DI CARATTERE, MA MAI INVADENTE.

THE DECORATIONS SEEM LIKE BRANCHES CROSSING EACH OTHER. IT IS EVOKES SPRING WITH MAGICAL AND SUGGESTIVE LIGHTING EFFECTS GIVING INTERIORS AN ORGANIC DESIGN WITH CHARACTER, BUT WITHOUT BEING INTRUSIVE.



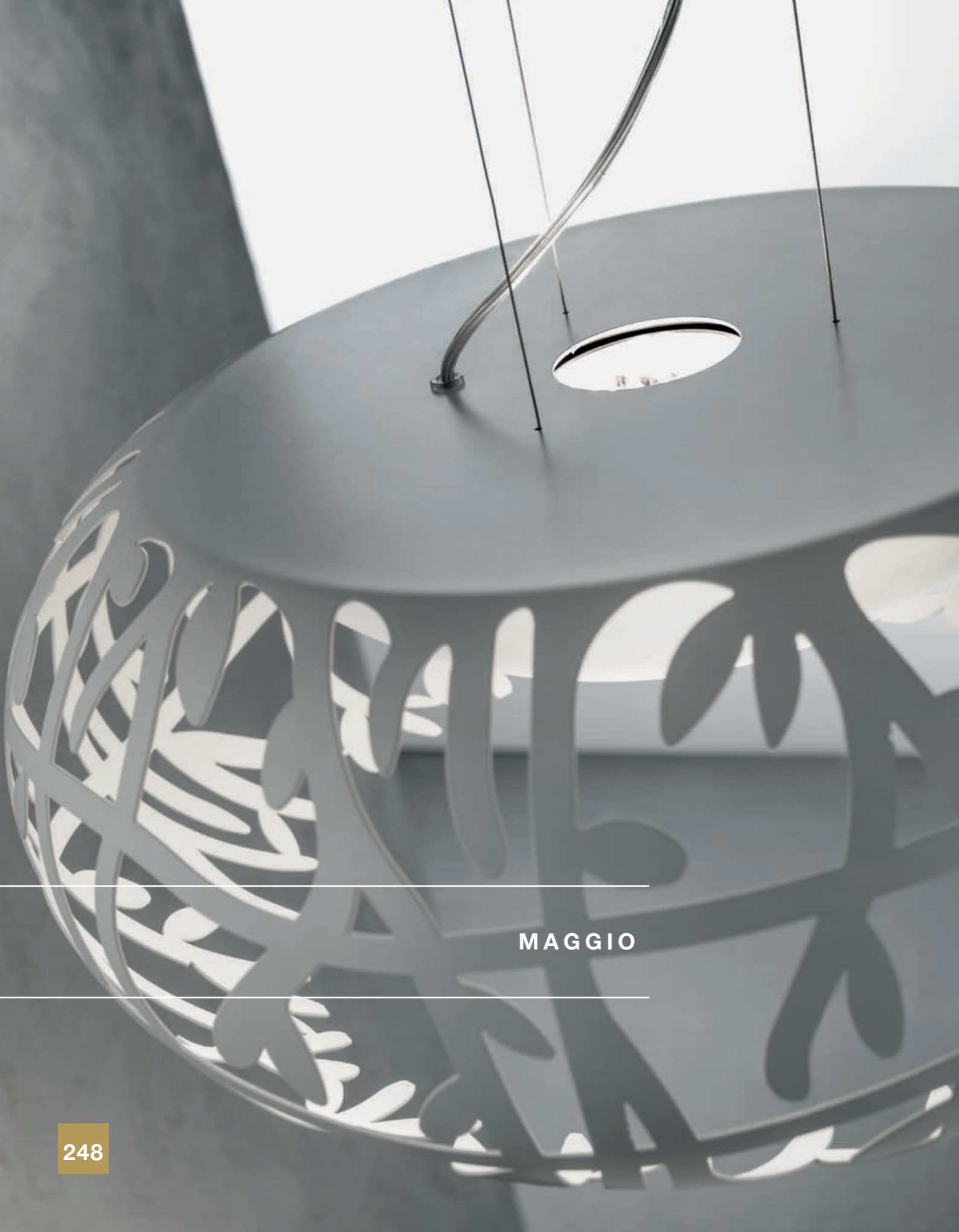

MAGGIO















MODELLO | MODEL

LAMPADINA | LAMP

MONTATURA | FRAME

DIFFUSORE | DIFFUSER

CODICE | CODE

**Maggio Pendant | Sospensione**

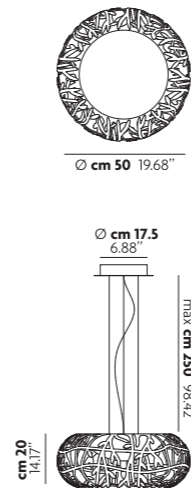
<p>[SO]</p>  <p>Ø cm 50 19.68"</p> <p>Ø cm 17.5 6.88"</p> <p>max cm 250 98.42"</p> <p>cm 20 7.87"</p>	<p><b>LED</b></p> <p>2700K          ▲ 17W   1700 lm          ▼ 17W   1700 lm          210-250V          CRI 92          MacAdam 3-Step</p>	<p>○ bianco opaco 9010 matt white 9010</p> <p>○ bianco satinato matt white</p> <p>● bronzo ramato coppery bronze</p>	<p>162001</p> <p>162002</p>
<p>LED included</p> <p>Peso netto: 6 Kg Weight net:</p>		<p>Confezione Packaging</p>	<p>Metallo Metal</p> <p>Polycarbonato Polycarbonate</p> <p>Peso lordo: 8.27 Kg Weight gross:</p> <p>n. Colli: 2 n. Pack:</p> <p>Volume m³: 0.09</p>

Note | Notes: LED con alimentazione diretta a tensione di rete (non necessita di driver LED). Dimmerabile con varialuce a taglio di fase. LED with direct power supply to the AC line voltage (LED driver not required). Dimmable with phase cut dimming.

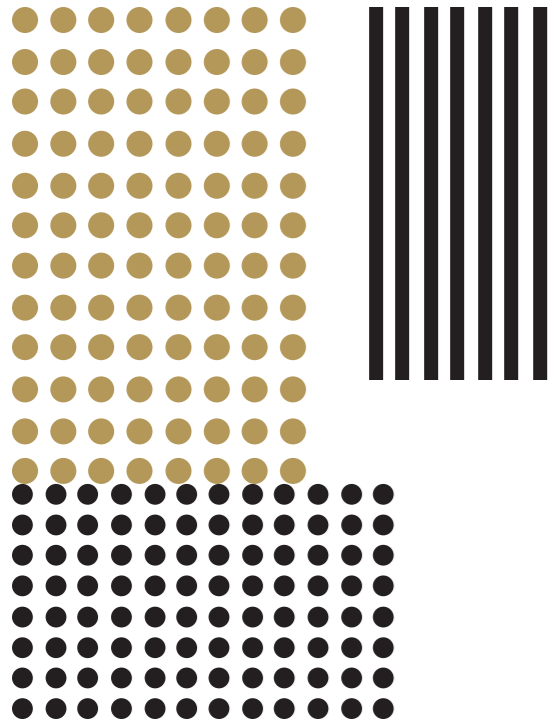

---

## NOSTALGIA

design: Dima Loginoff 2015

---

FORMA RETRÒ CHE SI FONDE CON L'ATTUALITÀ. SI UNISCONO COSÌ LA MAESTRIA NELL'ARTE DEL VETRO CON LA PIÙ AVANZATA TECNOLOGIA LED PERMETTENDO COMPOSIZIONI AMPIE ED ARMONIOSE PER ILLUMINARE DAL TAVOLO DA PRANZO ALLA LUSSUOSA HALL DI UN GRANDE ALBERGO. AFFASCINA CON LE SUE DIVERSE E PREZIOSE FINITURE.

A RETRO SHAPE WHICH BLENDS ALSO MODERN LINES, IN THIS WAY THE EXPERTISE OF BLOWN GLASS PRODUCTION AND THE MOST ADVANCED LED TECHNOLOGY JOIN FORCES ALLOWING NUMEROUS AND BALANCED COMPOSITIONS TO LIGHT UP ANYTHING FROM A DINNER TABLE TO THE LUXURY OF A HOTEL ATRIUM WITH BREATHTAKINGLY PRECIOUS FINISHES.





---

**NOSTALGIA**

---









NO-  
STAL-  
GIA



NO-  
STAL-  
GIA  
ROSE  
GOLD









NO-  
STAL-  
GIA  
GOLD



# NOSTALGIA



















NO-  
STAL-  
GIA  
CRYS-  
TAL



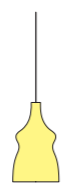

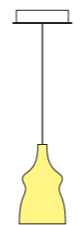
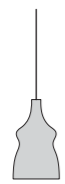
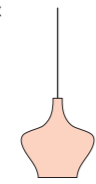
# NOSTALGIA composition

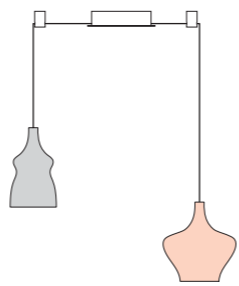
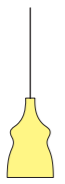
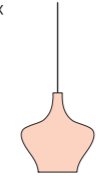

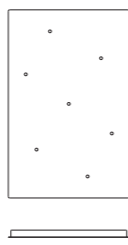
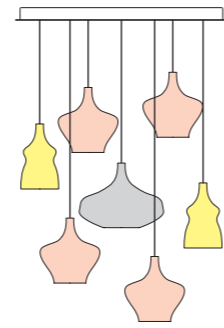
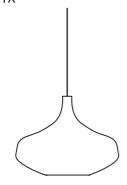
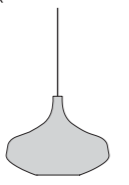
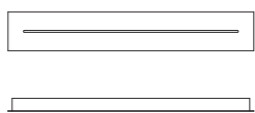
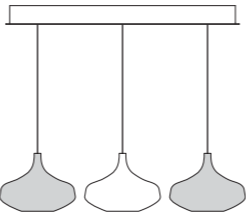







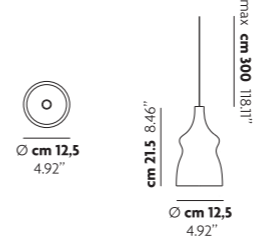





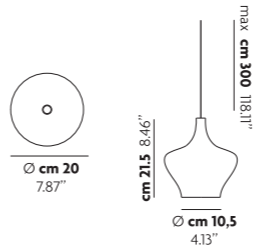

## Nostalgia example of composition

[Ex: 1] Single Radial Suspension   Sospensione Singola Decentrata								
	1x	+	1x	=				
								
codice   code	154003		154013					
[Ex: 2] Double Opposed Suspensions   Sospensioni Contrapposte								
	1x	+	1x	+	2x	+	1x	=
								
codice   code	154002		154008		130009		154026	
[Ex: 3] Cluster Rectangular 7 Lights Composition   Composizione 7 Rettangolare Luci								
	2x	+	4x	+	1x	+	1x	=
								
codice   code	154003		154008		154010		154019	
[Ex: 4] Short Track with 4 Lights   Binario Lineare Multiplo Corto 4 Luci								
	1x	+	2x	+	1x	=		
								
codice   code	154009		154010		154029			

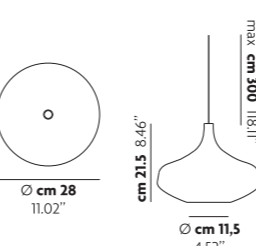
Note | Notes: .....

# NOSTALGIA

MODELLO | MODEL      LAMPADINA | LAMP      MONTATURA | FRAME      DIFFUSORE | DIFFUSER      CODICE | CODE

Nostalgia Glass Small Pendant   Sospensione				
[S01]		<b>LED</b> 2700K 9W   900 lm 210-250V CRI 92 MacAdam 3-Step	 cromo chrome	 cristallo crystal  cromo chrome  oro gold  oro rosa rose gold
		LED included	Metallo Metal	Vetro Glass
		Peso netto: 0.66 Kg Weight net:	<b>Confezione Packaging</b>	Peso lordo: 1.56 Kg Weight gross:
			n. Colli: 2 n. Pack:	Volume m <sup>3</sup> : 0.02 Volume m <sup>3</sup> :
				
Nostalgia Glass Medium Pendant   Sospensione				
[S02]		<b>LED</b> 2700K 9W   900 lm 210-250V CRI 92 MacAdam 3-Step	 cromo chrome	 cristallo crystal  cromo chrome  oro gold  oro rosa rose gold
		LED included	Metallo Metal	Vetro Glass
		Peso netto: 0.75 Kg Weight net:	<b>Confezione Packaging</b>	Peso lordo: 1.81 Kg Weight gross:
			n. Colli: 2 n. Pack:	Volume m <sup>3</sup> : 0.027 Volume m <sup>3</sup> :
				
Nostalgia Glass Large Pendant   Sospensione				
[S03]		<b>LED</b> 2700K 9W   900 lm 210-250V CRI 92 MacAdam 3-Step	 cromo chrome	 cristallo crystal  cromo chrome  oro gold  oro rosa rose gold
		LED included	Metallo Metal	Vetro Glass
		Peso netto: 1.02 Kg Weight net:	<b>Confezione Packaging</b>	Peso lordo: 2.9 Kg Weight gross:
			n. Colli: 2 n. Pack:	Volume m <sup>3</sup> : 0.035 Volume m <sup>3</sup> :
				

Le sospensioni devono essere installate sui **rosoni** presenti alle pagine 342-349  
 The pendants must be installed with one of the **canopy** options listed on page 342-349  
 Les suspensions doivent être installées sur les **patères** présentées dans les pages 342-349  
 Die Hängeleuchten sollen auf die **Rosetten** auf Seiten 342-349 montiert werden  
 Las lámparas de suspensión se deben instalar en los **rósetones** a pagina 342-349

Note | Notes: LED con alimentazione diretta a tensione di rete (non necessita di driver LED). Dimmerabile con varialuce a taglio di fase.  
 LED with direct power supply to the AC line voltage (LED driver not required). Dimmable with phase cut dimming.

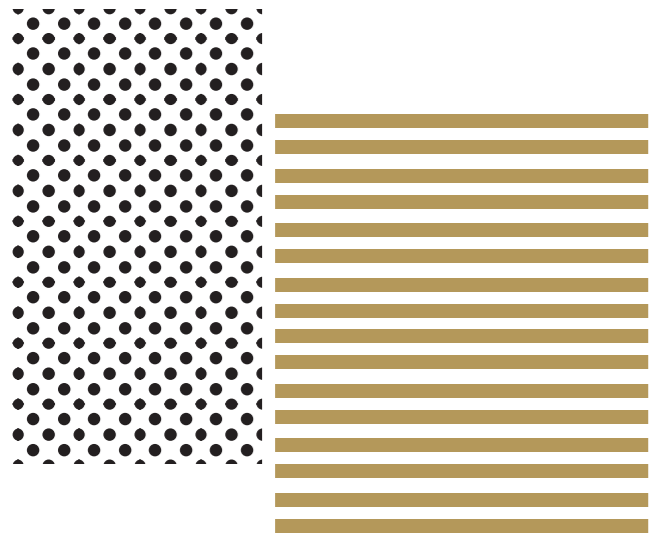

---

## RANDOM

design: Chia-Ying Lee 2017

---

VETRO SOFFIATO FUSO IN UN DESIGN NON CONVENZIONALE, CREANDO LUMINOSITÀ UNICHE ED EMOZIONALI GRAZIE ALLA PREZIOSITÀ DEI DETTAGLI E DEI MATERIALI. LA SUA MODULARITÀ PERMETTE DI RICREARE COMPOSIZIONI SEMPRE NUOVE.

MELTED BLOWN GLASS IN AN UNCONVENTIONAL DESIGN, CREATING UNIQUE AND EMOTIONAL EFFECTS THANKS TO THE USE OF PRECIOUS MATERIALS AND DETAILS. THE MODULARITY OF THE RANGE ALLOWS YOU TO CREATE AN INFINITE VARIETY OF CLUSTERS.







RANDOM  
STUDIO  
ITALIA  
DESIGN





THE  
LIGHTING  
MAKERS  
2017





RANDOM  
STUDIO  
ITALIA  
DESIGN





# RANDOM composition

## Random example of composition

[Ex: 1] Single Mini Suspensions | Sospensione Singola Mini

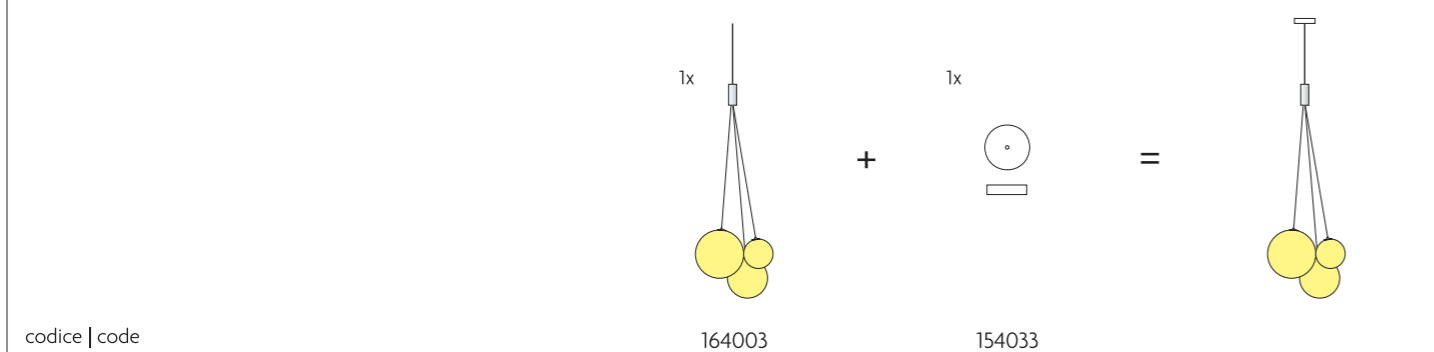

[Ex: 2] Cluster 3 Lights Composition | Composizione 3 Luci

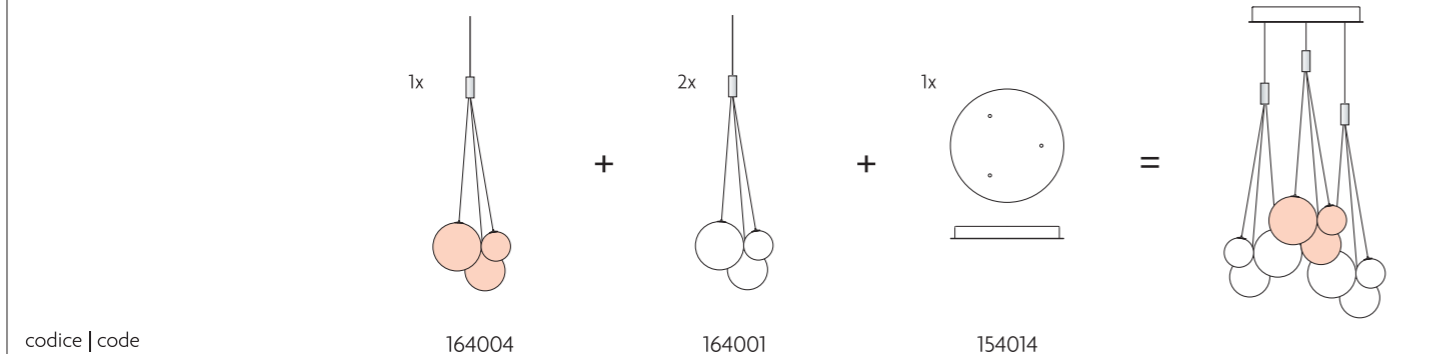

[Ex: 3] Recessed Lights Composition | Composizione Lampade Incassate

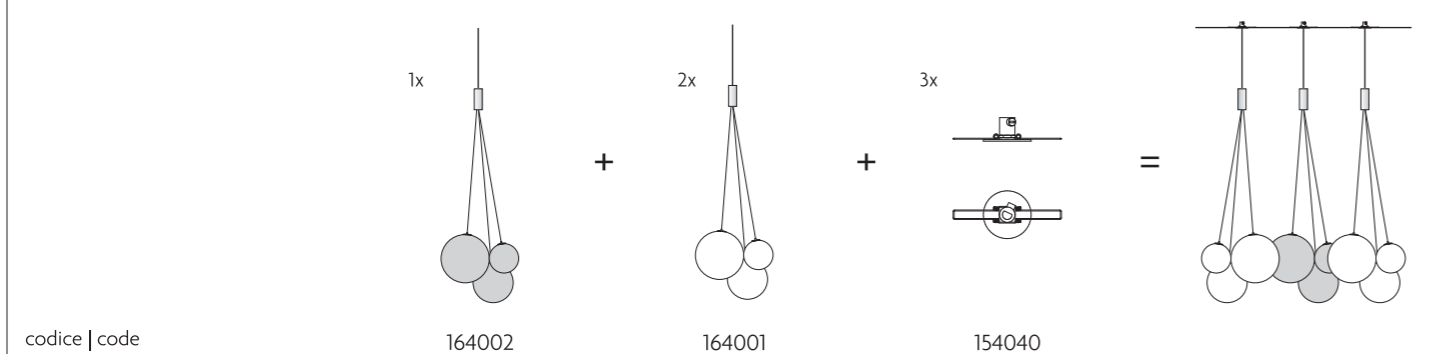

[Ex: 4] Cluster Rectangular 7 Lights Composition | Composizione 7 Rettangolare Luci

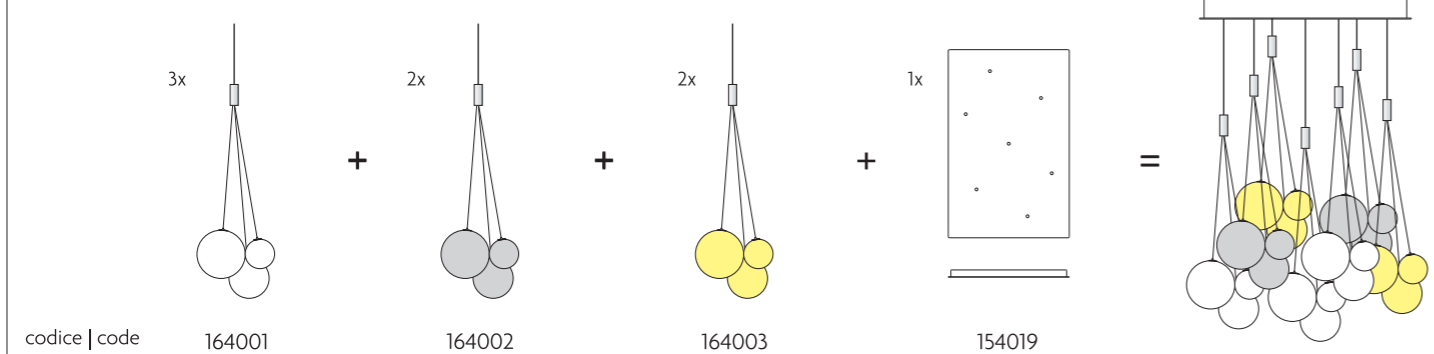

Note | Notes: .....

# RANDOM

MODELLO | MODEL

LAMPADINA | LAMP

MONTATURA | FRAME

DIFFUSORE | DIFFUSER

CODICE | CODE

## Random Pendant | Sospensione

[SO]

cm 29 11.41"

cm 26 10.23"

max cm 400 157.48"

cm 79.5 31.3"

cm 46 18.11"

cm 57 22.44"

cm 50 19.68"

cm 18 7.08"

cm 11 4.33"

cm 14 5.51"

**LED**

2700K  
3x1W | 450 lm  
350mA  
CRI 90  
MacAdam 3-Step

LED and DRIVER included

Metallo Metal

Vetro Soffiato Blown Glass

0,5 m<sup>2</sup> CE Energy saving PG ip 20 DIM TRIAC

Peso netto: 1,1 Kg Weight net:

Confezione Packaging

Peso lordo: --- Kg Weight gross:

n. Colli: - n. Pack:

Volume m<sup>3</sup>: ---- Volume m<sup>3</sup>:

cristallo crystal	164001
cromo chrome	164002
oro gold	164003
oro rosa rose gold	164004

Le sospensioni devono essere installate sui **rosoni** presenti alle pagine 342-349  
 The pendants must be installed with one of the **canopy** options listed on page 342-349  
 Les suspensions doivent être installées sur les **patères** présentées dans les pages 342-349  
 Die Hängeleuchten sollen auf die **Rosetten** auf Seiten 342-349 montiert werden  
 Las lámparas de suspensión se deben instalar en los **rosetones** a pagina 342-349

Note | Notes: .....

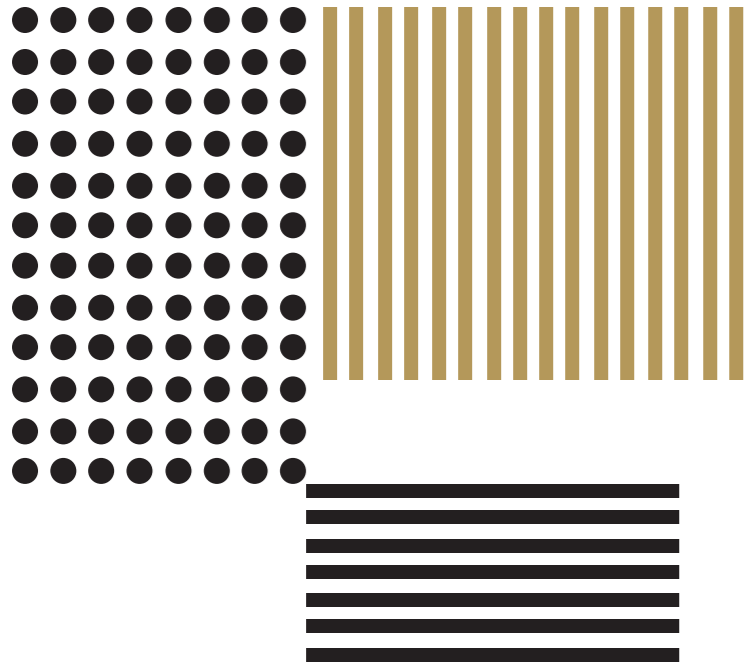

---

## BLOW

design: Pio e Tito Toso 2005

---

UNA BOLLA DI SAPONE MAGICA E LEGGERA GRAZIE ALLA TRASPARENZA DEL VETRO SOFFIATO PERMETTENDO ALLA LUCE AL SUO INTERNO DI RESPIRARE E ILLUMINARE L'AMBIENTE CREANDO MERAVIGLIOSI FASCI DI LUCE.

THIS MAGICAL AND ETHEREAL SOAP BUBBLE ALLOWS THE LIGHT TO "BREATH" THROUGH A BLOWN GLASS DIFFUSER, LIGHTING SPACES AND CREATING WONDERFUL EFFECTS.



# BLOW

MODELLO | MODEL

LAMPADINA | LAMP

MONTATURA | FRAME

DIFFUSORE | DIFFUSER

CODICE | CODE

## Blow Led Table | Tavolo

<p>[TA2]</p> <p>Ø cm 26 10.23"</p> <p>cm 41 16.14"</p> <p>Ø cm 10 3.93"</p>	<p><b>LED</b></p> <p><b>2700K</b> 4.5W   500 lm 500 mA CRI 90 MacAdam 3-Step</p> <p><b>LED</b> included</p>	<p>○ cromo chrome</p> <p>Metallo Metal</p>	<p>○ cristallo crystal</p> <p>Vetro Soffiato Blown Glass</p>	<p>008004</p>
<p>0,5 m<sup>2</sup> CE Energy saving PG ip40</p>	<p>Peso netto: 4 Kg Weight net:</p>	<p><b>Confezione Packaging</b></p>	<p>Peso lordo: 5.81 Kg Weight gross:</p>	<p>n. Colli: 1 n. Pack: 1 Volume m<sup>3</sup>: 0.113</p>



Note | Notes: .....



---

## MAKE-UP

design: Studio Italia Design 2015

---

INSPIRATE AL MONDO DEL MAKE-UP DELL'ALTA MODA QUESTE LAMPADE COMPONENTI E MODULARI IN VETRO SOFFIATO CHE RACCHIUDONO UN CUORE A LED TRASPORTANO LA LUCE CREANDO INFINITE COMPOSIZIONI.

INSPIRED BY THE MAKE-UP WORLD OF FASHION, THESE MODULAR FIXTURES MADE OF BLOWN GLASS WHICH ENCLOSE AN LED HEART CREATE AN INFINITE NUMBER OF COMPOSITIONS BRINGING LIGHT WHERE THERE ISN'T ANY.





MAKE-UP  
STUDIO  
ITALIA  
DESIGN



# MAKEUP



MODELLO | MODEL      LAMPADINA | LAMP      MONTATURA | FRAME      DIFFUSORE | DIFFUSER      CODICE | CODE

## Makeup Small Wall & Ceiling | Parete & Plafoniera

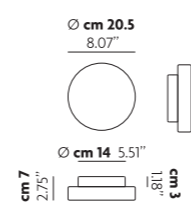
<p>[AP2-PL2]</p> 	<p><b>LED</b></p> <p>3000K 9W   950 lm 210-250V CRI 92 MacAdam 3-Step</p> <p>LED included</p>	<p>bianco opaco 9016 matt white 9016</p> <p>Metallo Metal</p>	<p>bianco latte satinato matt milk white</p> <p>Vetro Glass</p>	<p>150003</p>	
<p>0,5 m<sup>2</sup> CE Energy saving PG IP30 DIM TRIAC</p>		<p>Peso netto: 1.3 Kg Weight net:</p>	<p><b>Confezione Packaging</b>      Peso lordo: 1.89 Kg Weight gross:</p>	<p>n. Colli: 1 n. Pack:</p>	<p>Volume m<sup>3</sup>: 0.026 Volume m<sup>3</sup>:</p>

## Makeup Medium Wall & Ceiling | Parete & Plafoniera

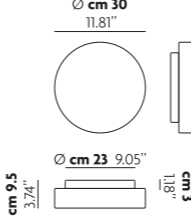
<p>[AP1-PL1]</p> 	<p><b>LED</b></p> <p>3000K 17W   1800 lm 210-250V CRI 92 MacAdam 3-Step</p> <p>LED included</p>	<p>bianco opaco 9016 matt white 9016</p> <p>Metallo Metal</p>	<p>bianco latte satinato matt milk white</p> <p>Vetro Glass</p>	<p>150002</p>	
<p>0,5 m<sup>2</sup> CE Energy saving PG IP30 DIM TRIAC</p>		<p>Peso netto: 2.32 Kg Weight net:</p>	<p><b>Confezione Packaging</b>      Peso lordo: 2.89 Kg Weight gross:</p>	<p>n. Colli: 1 n. Pack:</p>	<p>Volume m<sup>3</sup>: 0.026 Volume m<sup>3</sup>:</p>

## Makeup Large Wall & Ceiling | Parete & Plafoniera

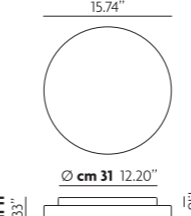
<p>[AP-PL]</p> 	<p><b>LED</b></p> <p>3000K 17W   1800 lm 210-250V CRI 92 MacAdam 3-Step</p> <p>LED included</p>	<p>bianco opaco 9016 matt white 9016</p> <p>Metallo Metal</p>	<p>bianco latte satinato matt milk white</p> <p>Vetro Glass</p>	<p>150001</p>	
<p>0,5 m<sup>2</sup> CE Energy saving PG IP30 DIM TRIAC</p>		<p>Peso netto: 3.88 Kg Weight net:</p>	<p><b>Confezione Packaging</b>      Peso lordo: 5.04 Kg Weight gross:</p>	<p>n. Colli: 1 n. Pack:</p>	<p>Volume m<sup>3</sup>: 0.057 Volume m<sup>3</sup>:</p>

Note | Notes: LED con alimentazione diretta a tensione di rete (non necessita di driver LED). Dimmerabile con varialuce a taglio di fase.  
LED with direct power supply to the AC line voltage (LED driver not required). Dimmable with phase cut dimming.

Le lampade sono collegabili tra di loro fino ad un massimo di 50 apparecchi per ogni singolo punto di alimentazione elettrica.  
Lamps can be daisy chained up to a maximum of 50 devices for each point of power supply.

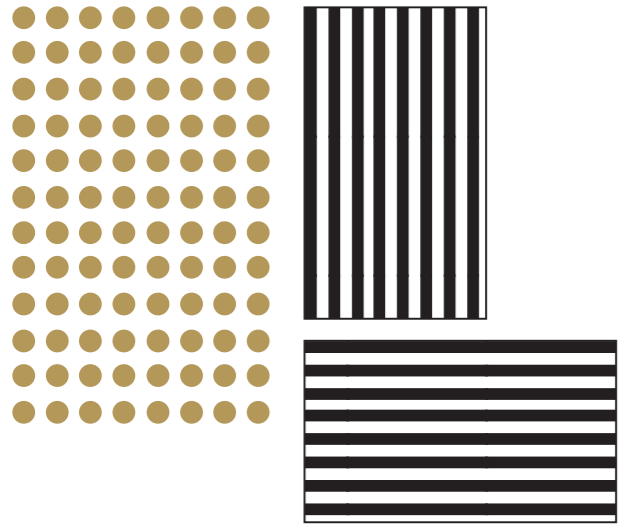

---

## BEETLE

design: Studio Italia Design 2014

---

UNA SINTESI GEOMETRICA TRA MATERIALI DUREVOLI E SORGENTI LUMINOSE MODERNE. RACCHIUDE IN SÉ LA LUCE ALLO STATO PURO E LA DIFFONDE

A GEOMETRIC FUSION BETWEEN LONG LASTING MATERIALS AND MODERN SOURCES OF LIGHT WHICH HOLDS WITHIN LIGHT IN IT'S PUREST FORM AND SHEDS IT IN TO ANY ENVIRONMENT.





---

## BEETLE

---



---

# BEETLE

---



# BEETLE

MODELLO | MODEL LAMPADINA | LAMP MONTATURA | FRAME DIFFUSORE | DIFFUSER CODICE | CODE

## Beetle Mini Cube Wall & Ceiling | Parete & Plafoniera

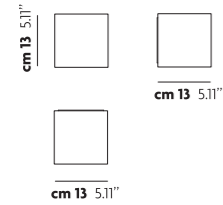
<p>[AP-PL]</p> 	<p><b>LED</b></p> <p><b>3000K</b> 17W   1800 lm 210-250V CRI 92 MacAdam 3-Step</p>	<p>bianco opaco 9010 matt white 9010</p>	<p>bianco + trasparente rigato white + clear ribbed</p> <p>bianco white</p>	<p>145001</p> <p>145009</p>
<p>LED included</p> <p>Metallo Metal</p>		<p>Policarbonato Polycarbonate</p>		<p>Peso netto: 0.64 Kg Weight net:</p> <p><b>Confezione Packaging</b></p> <p>Peso lordo: 1.1 Kg Weight gross:</p> <p>n. Colli: 2 n. Pack:</p> <p>Volume m<sup>3</sup>: 0.009 Volume m<sup>3</sup>:</p>

## Beetle Medium Cube Wall & Ceiling | Parete & Plafoniera

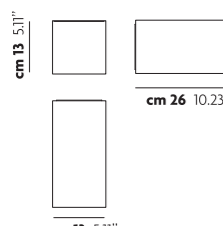
<p>[AP1-PL1]</p> 	<p><b>LED</b></p> <p><b>3000K</b> 17W   1800 lm 210-250V CRI 92 MacAdam 3-Step</p>	<p>bianco opaco 9010 matt white 9010</p>	<p>bianco + trasparente rigato white + clear ribbed</p>	<p>145002</p>
<p>LED included</p> <p>Metallo Metal</p>		<p>Policarbonato Polycarbonate</p>		<p>Peso netto: 0.67 Kg Weight net:</p> <p><b>Confezione Packaging</b></p> <p>Peso lordo: 1.6 Kg Weight gross:</p> <p>n. Colli: 2 n. Pack:</p> <p>Volume m<sup>3</sup>: 0.017 Volume m<sup>3</sup>:</p>

## Beetle Mini 60° Cube Wall & Ceiling | Parete & Plafoniera

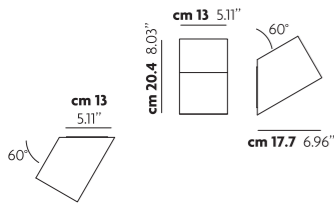
<p>[AP2-PL2]</p> 	<p><b>LED</b></p> <p><b>3000K</b> 17W   1800 lm 210-250V CRI 92 MacAdam 3-Step</p>	<p>bianco opaco 9010 matt white 9010</p>	<p>bianco + trasparente rigato white + clear ribbed</p>	<p>145003</p>
<p>LED included</p> <p>Metallo Metal</p>		<p>Policarbonato Polycarbonate</p>		<p>Peso netto: 0.88 Kg Weight net:</p> <p><b>Confezione Packaging</b></p> <p>Peso lordo: 1 Kg Weight gross:</p> <p>n. Colli: 2 n. Pack:</p> <p>Volume m<sup>3</sup>: 0.009 Volume m<sup>3</sup>:</p>

## Beetle Medium 60° Cube Wall & Ceiling | Parete & Plafoniera

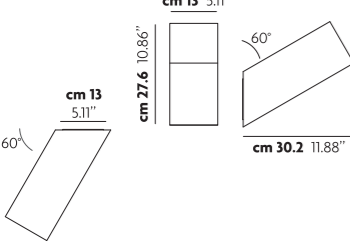
<p>[AP3-PL3]</p> 	<p><b>LED</b></p> <p><b>3000K</b> 17W   1800 lm 210-250V CRI 92 MacAdam 3-Step</p>	<p>bianco opaco 9010 matt white 9010</p>	<p>bianco + trasparente rigato white + clear ribbed</p>	<p>145004</p>
<p>LED included</p> <p>Metallo Metal</p>		<p>Policarbonato Polycarbonate</p>		<p>Peso netto: 0.97 Kg Weight net:</p> <p><b>Confezione Packaging</b></p> <p>Peso lordo: 1.48 Kg Weight gross:</p> <p>n. Colli: 2 n. Pack:</p> <p>Volume m<sup>3</sup>: 0.020 Volume m<sup>3</sup>:</p>

Note | Notes: LED con alimentazione diretta a tensione di rete (non necessita di driver LED). Dimmerabile con varialuce a taglio di fase.  
LED with direct power supply to the AC line voltage (LED driver not required). Dimmable with phase cut dimming.

# BEETLE

MODELLO | MODEL LAMPADINA | LAMP MONTATURA | FRAME DIFFUSORE | DIFFUSER CODICE | CODE

## Beetle Small Pyramid Wall & Ceiling | Parete & Plafoniera

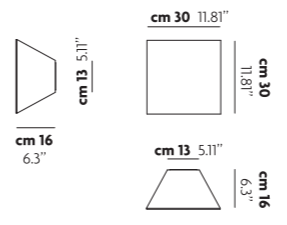
<p>[AP4-PL4]</p> 	<p><b>LED</b></p> <p><b>3000K</b> 17W   1800 lm 210-250V CRI 92 MacAdam 3-Step</p>	<p>bianco opaco 9010 matt white 9010</p>	<p>bianco + trasparente rigato white + clear ribbed</p>	<p>145005</p>
<p>LED included</p> <p>Metallo Metal</p>		<p>Policarbonato Polycarbonate</p>		<p>Peso netto: 1.17 Kg Weight net:</p> <p><b>Confezione Packaging</b></p> <p>Peso lordo: 2.5 Kg Weight gross:</p> <p>n. Colli: 2 n. Pack:</p> <p>Volume m<sup>3</sup>: 0.027 Volume m<sup>3</sup>:</p>

## Beetle Large Pyramid Wall & Ceiling | Parete & Plafoniera

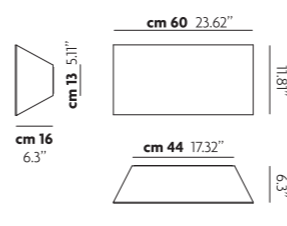
<p>[AP6-PL6]</p> 	<p><b>LED</b></p> <p><b>3000K</b> 2x17W   3600 lm 210-250V CRI 92 MacAdam 3-Step</p>	<p>bianco opaco 9010 matt white 9010</p>	<p>bianco + trasparente rigato white + clear ribbed</p>	<p>145007</p>
<p>LED included</p> <p>Metallo Metal</p>		<p>Policarbonato Polycarbonate</p>		<p>Peso netto: 2.5 Kg Weight net:</p> <p><b>Confezione Packaging</b></p> <p>Peso lordo: 4.9 Kg Weight gross:</p> <p>n. Colli: 2 n. Pack:</p> <p>Volume m<sup>3</sup>: 0.13 Volume m<sup>3</sup>:</p>

Note | Notes: LED con alimentazione diretta a tensione di rete (non necessita di driver LED). Dimmerabile con varialuce a taglio di fase.  
LED with direct power supply to the AC line voltage (LED driver not required). Dimmable with phase cut dimming.

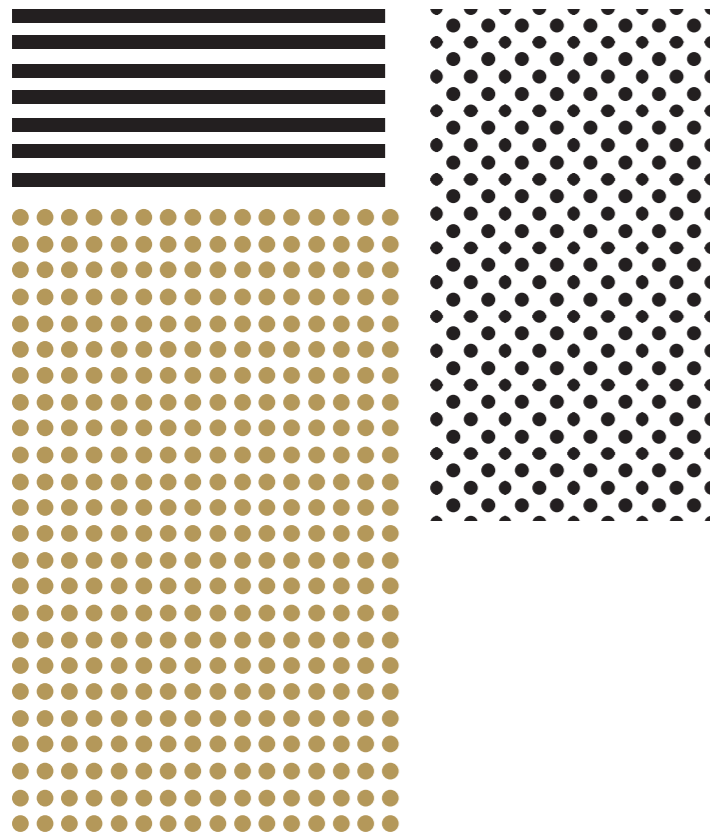

---

## MILLO

design: Marta Sansoni 2016

---

E' UNA LAMPADA DI GRANDI DIMENSIONI IN TESSUTO DALLE FORME MORBIDE ED ORGANICHE CHE DIFFONDE LA LUCE DALLE NOSTRE PARETI E SOFFITTI, UN OGGETTO D'ARREDO CHE RENDE L'AMBIENTE ESCLUSIVO.

IT IS AN HIGH VOLUME FABRIC LAMP, SOFT AND ORGANIC, DIFFUSING LIGHT AROUND THE ROOM AND AT THE SAME TIME FINISHING THE ENVIRONMENT IT IS IN.





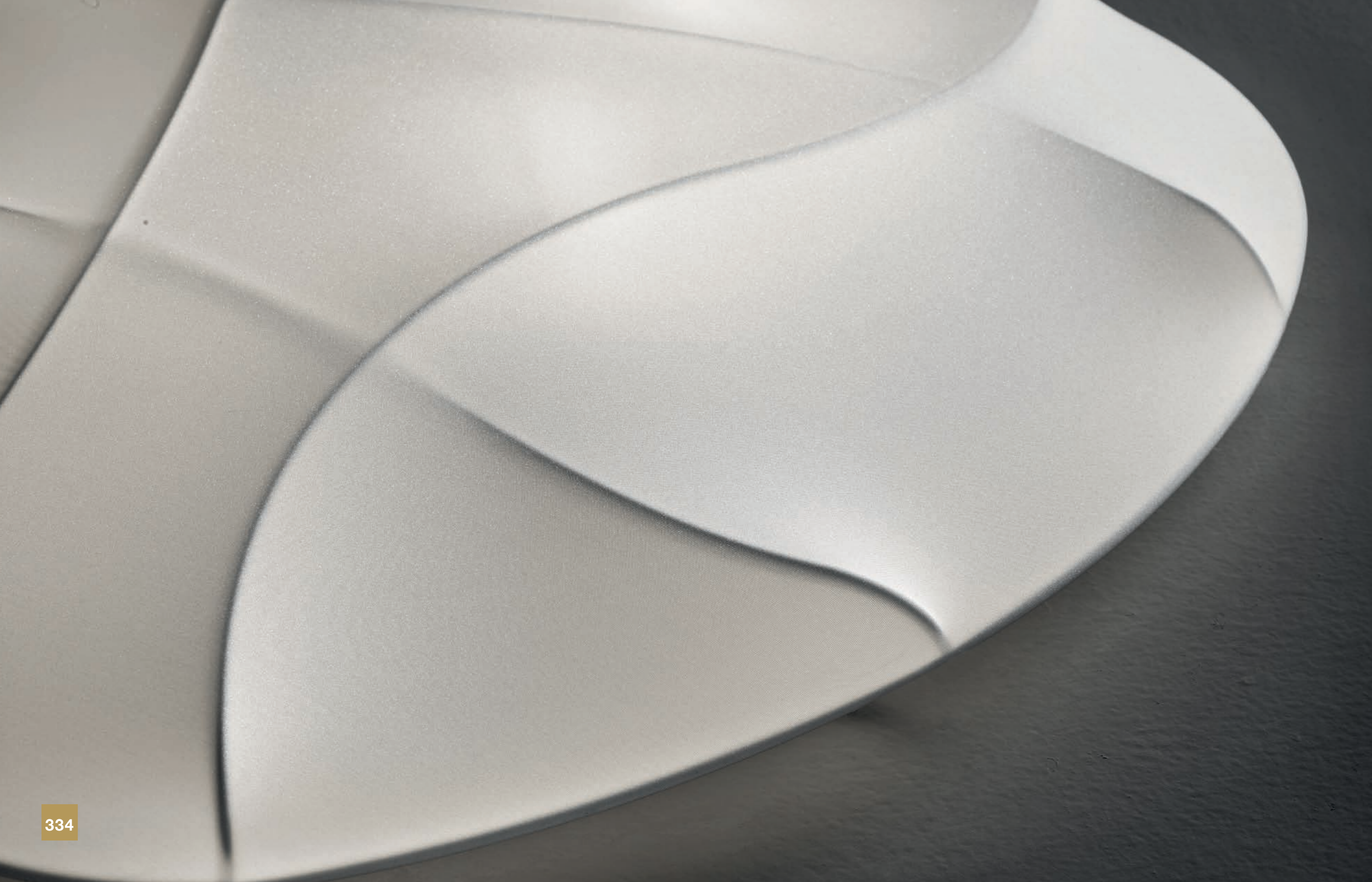

# MILLO

MODELLO | MODEL

LAMPADINA | LAMP

MONTATURA | FRAME

DIFFUSORE | DIFFUSER

CODICE | CODE

## Millo Small Wall & Ceiling | Parete & Plafoniera

<p>[AP1-PL1]</p> <p>cm 60 23.62"</p> <p>cm 50 19.68"</p> <p>Ø cm 23.5 9.25"</p> <p>cm 15 5.91"</p>	<p>E27 CFL 2x max 30W</p> <p>or</p> <p>E27 LED 2x max available</p> <p>Lampadine non include Bulbs not included</p>	<p>bianco opaco 9010 matt white 9010</p>	<p>bianco white</p>	<p>157001</p>
<p>0,5 m<sup>2</sup> CE Energy saving PG IP20 DIM</p>		<p>Peso netto: 1.1 Kg Weight net:</p>	<p><b>Confezione Packaging</b> Peso lordo: 1.73 Kg Weight gross:</p>	<p>n. Colli: 1 n. Pack: 1 Volume m<sup>3</sup>: 0.031 Volume m<sup>3</sup>:</p>

## Millo Medium Wall & Ceiling | Parete & Plafoniera

<p>[AP2-PL2]</p> <p>cm 90 35.43"</p> <p>cm 75 29.52"</p> <p>Ø cm 44.5 17.51"</p> <p>cm 22 8.66"</p>	<p>E27 CFL 4x max 30W</p> <p>or</p> <p>E27 LED 4x max available</p> <p>Lampadine non include Bulbs not included</p>	<p>bianco opaco 9010 matt white 9010</p>	<p>bianco white</p>	<p>157002</p>
<p>0,5 m<sup>2</sup> CE Energy saving PG IP20 DIM</p>		<p>Peso netto: 2.25 Kg Weight net:</p>	<p><b>Confezione Packaging</b> Peso lordo: 5.41 Kg Weight gross:</p>	<p>n. Colli: 1 n. Pack: 1 Volume m<sup>3</sup>: 0.122 Volume m<sup>3</sup>:</p>

## Millo Large Wall & Ceiling | Parete & Plafoniera

<p>[AP3-PL3]</p> <p>cm 120 47.24"</p> <p>cm 100 39.37"</p> <p>Ø cm 44.5 17.51"</p> <p>cm 28 11.02"</p>	<p>E27 CFL 4x max 30W</p> <p>or</p> <p>E27 LED 4x max available</p> <p>Lampadine non include Bulbs not included</p>	<p>bianco opaco 9010 matt white 9010</p>	<p>bianco white</p>	<p>157003</p>
<p>0,5 m<sup>2</sup> CE Energy saving PG IP20 DIM</p>		<p>Peso netto: 2.7 Kg Weight net:</p>	<p><b>Confezione Packaging</b> Peso lordo: 7.49 Kg Weight gross:</p>	<p>n. Colli: 1 n. Pack: 1 Volume m<sup>3</sup>: 0.22 Volume m<sup>3</sup>:</p>



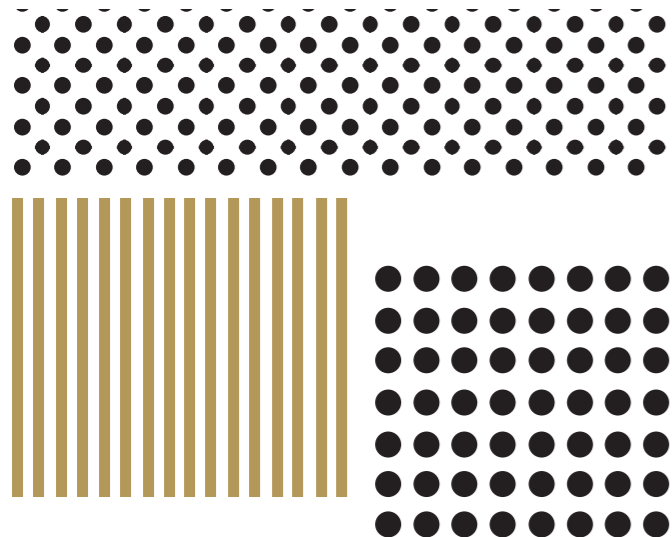

---

## VAPOR

design: Karim Rashid 2012

---

SINUOSA COME UN CORPO FEMMINILE COMPOSTA DAL SUO DIFFUSORE IN POLICARBONATO AD ONDE, È UN ELEMENTO IRRINUNCIABILE PER TUTTI GLI AMBIENTI DOVE È RICERCATO UN DESIGN ESCLUSIVO.

WELL-ROUNDED LIKE A FEMALE BODY WITH ITS WAVED POLYCARBONATE DIFFUSERS, IT IS AN PIECE THAT CANNOT BE ABSENT IN AN ENVIRONMENT WHERE YOUR GOAL IS EXCLUSIVE DESIGN.



# VAPOR

MODELLO | MODEL

LAMPADINA | LAMP

MONTATURA | FRAME

DIFFUSORE | DIFFUSER

CODICE | CODE

Vapor Floor | Terra

[LT1]

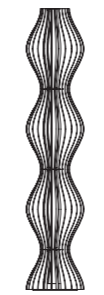

cm 196 77 1/8"

Ø cm 35.6  
14.01"



Ø cm 35.6  
14.01"

R7s QT-DE12 short  
1x max 80W eco

and

E27 Classic A60  
6x max 77W eco

or

E27 CFL  
6x max 30W

or

E27 LED  
6x max available

Lampadine non include  
Bulbs not included

○ bianco opaco 9010  
matt white 9010

○ bianco opaco  
matt white

129009

Metallo  
Metal

Polycarbonato  
Polycarbonate

0,5 m³ CE energy saving PG IP20 DIM DIMMER included

Peso netto: 24 Kg  
Weight net:

**Confezione Packaging**

Peso lordo: 32.55 Kg  
Weight gross:

n. Colli: 2  
n. Pack:

Volume m³: 0.414  
Volume m³:

## VAPOR STUDIO ITALIA DESIGN



340

THE  
LIGHTING  
MAKERS  
2017



Note | Notes:

COM  
PO  
SITIO-  
NS

# TRACK system

MODELLO | MODEL INFO | INFO COLORE | COLOR SISTEMA | SYSTEM CODICE | CODE

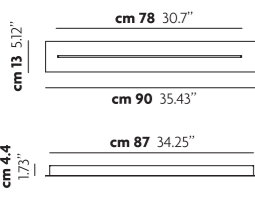

## Lights Track Short Linear Track | Binario Lineare

<p>[TR1]</p> 	<p>Binario lineare multiplo modello standard massimo 7 sospensioni</p> <p>Multiple linear track standard version max 7 suspensions</p>	<p> bianco opaco 9010 matt white 9010</p>	<p><b>Track system</b></p>	<p>154029</p>	
<p>CE </p>		<p>Peso netto: 5.5 Kg Weight net:</p>	<p><b>Confezione Packaging</b></p>	<p>Peso lordo: 6.37 Kg Weight gross:</p>	<p>n. Colli: 1 n. Pack: Volume m<sup>3</sup>: 0.019</p>

## Track System List Short Maximum Quantity | Quantità Installabili

pendenti allineati   pendants aligned		pendenti sfalsati   staggered pendants	
<b>in line</b>		<b>up&amp;down</b>	
max 7	mod. A-Tube	max 7	mod. A-Tube
max 7	mod. A-Tube Nano	max 7	mod. A-Tube Nano
max 4	mod. Kelly Cluster	max 7	mod. Kelly Cluster
max 7	mod. Nostalgia Small	max 7	mod. Nostalgia Small
max 4	mod. Nostalgia Medium	max 7	mod. Nostalgia Medium
max 3	mod. Nostalgia Large	max 5	mod. Nostalgia Large
max 7	mod. Rain	max 7	mod. Rain
max 3	mod. Random	max 5	mod. Random
max 7	mod. Spider	max 7	mod. Spider

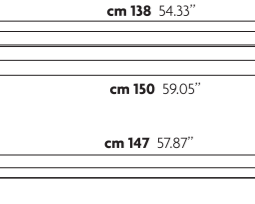
## Lights Track Long Linear Track | Binario Lineare

<p>[TR2]</p> 	<p>Binario lineare multiplo modello standard massimo 11 sospensioni</p> <p>Multiple linear track standard version max 11 suspensions</p>	<p> bianco opaco 9010 matt white 9010</p>	<p><b>Track system</b></p>	<p>154030</p>	
<p>CE </p>		<p>Peso netto: 8.8 Kg Weight net:</p>	<p><b>Confezione Packaging</b></p>	<p>Peso lordo: 10.15 Kg Weight gross:</p>	<p>n. Colli: 1 n. Pack: Volume m<sup>3</sup>: 0.031</p>

## Track System List Long Maximum Quantity | Quantità Installabili







pendenti allineati   pendants aligned		pendenti sfalsati   staggered pendants	
<b>in line</b>		<b>up&amp;down</b>	
max 11	mod. A-Tube	max 11	mod. A-Tube
max 11	mod. A-Tube Nano	max 11	mod. A-Tube Nano
max 8	mod. Kelly Cluster	max 11	mod. Kelly Cluster
max 11	mod. Nostalgia Small	max 11	mod. Nostalgia Small
max 7	mod. Nostalgia Medium	max 11	mod. Nostalgia Medium
max 5	mod. Nostalgia Large	max 9	mod. Nostalgia Large
max 11	mod. Rain	max 11	mod. Rain
max 5	mod. Random	max 9	mod. Random
max 11	mod. Spider	max 11	mod. Spider

Note | Notes: Le sospensioni **Sky-Fall** non possono essere installate su questi binari. Vedere alla pagina \*\*\*  
The **Sky-Fall** suspensions can not be installed on this track light. Shown page \*\*\*

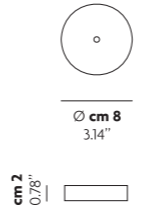



# CLUSTER system

MODELLO | MODEL INFO | INFO COLORE | COLOR SISTEMA | SYSTEM CODICE | CODE

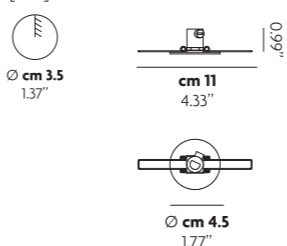

## Single Mini Canopy | Rosone

<p>[RM1]</p> 	<p>Rosone per lampada singola dimensioni ridotte</p> <p>Single ceiling bracket small size</p>	<p> bianco opaco 9010 matt white 9010</p> <p> nero opaco matt black</p> <p> bronzo ramato coppery bronze</p> <p> cromo chrome</p>	<p><b>Single</b></p>	<p>154033</p> <p>154034</p> <p>154035</p> <p>154036</p>	
<p>CE </p>		<p>Peso netto: 0.2 Kg Weight net:</p>	<p><b>Confezione Packaging</b></p>	<p>Peso lordo: 0.3 Kg Weight gross:</p>	<p>n. Colli: 1 n. Pack: Volume m<sup>3</sup>: 0.002</p>

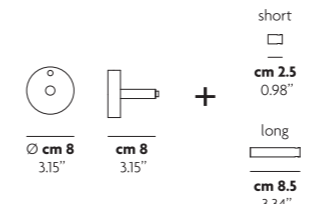

## Recessed Micro Canopy Canopy | Rosone

<p>[R11]</p> 	<p>Rosone da incasso per lampada singola</p> <p>Recessed bracket for single lamp</p>	<p> bianco opaco 9010 matt white 9010</p> <p> cromo chrome</p>	<p><b>Recessed system</b></p>	<p>154037</p> <p>154040</p>	
<p>CE </p>		<p>Peso netto: 0.032 Kg Weight net:</p>	<p><b>Confezione Packaging</b></p>	<p>Peso lordo: 0.2 Kg Weight gross:</p>	<p>n. Colli: 1 n. Pack: Volume m<sup>3</sup>: 0.002</p>

## Standard Wall Canopy Wall Canopy | Rosone Parete

<p>[RP1]</p> 	<p>Rosone a parete per sospensioni sistema componibile</p> <p>Wall bracket for pendant suspension modular system</p>	<p> cromo chrome</p>	<p><b>Wall system</b></p>	<p>154038</p>	
<p>CE </p>		<p>Peso netto: 0.8 Kg Weight net:</p>	<p><b>Confezione Packaging</b></p>	<p>Peso lordo: 1.1 Kg Weight gross:</p>	<p>n. Colli: 1 n. Pack: Volume m<sup>3</sup>: 0.002</p>

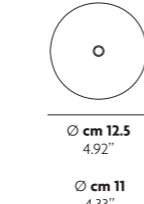
## Single Standard Canopy | Rosone



<p>[RO1]</p> 	<p>Rosone per lampada singola versione standard</p> <p>Single ceiling bracket standard size</p>	<p> bianco opaco 9010 matt white 9010</p>	<p><b>Single</b></p>	<p>154013</p>	
<p>CE </p>		<p>Peso netto: 0.4 Kg Weight net:</p>	<p><b>Confezione Packaging</b></p>	<p>Peso lordo: 0.48 Kg Weight gross:</p>	<p>n. Colli: 1 n. Pack: Volume m<sup>3</sup>: 0.002</p>

Note | Notes: .....

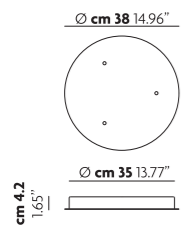

# CLUSTER system

MODELLO | MODEL      INFO | INFO      COLORE | COLOR      SISTEMA | SYSTEM      CODICE | CODE

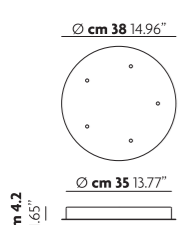

## Cluster 3 Lights Round Cluster Canopy | Rosone Cluster

<p>[RO3]</p> 	<p>Rosone circolare per 3 sospensioni Ceiling bracket for 3 suspensions</p>	<p>bianco opaco 9010 matt white 9010</p>	<p><b>Cluster system</b></p>	<p>154014</p>		
<p>CE </p>		<p>Peso netto: 3.55 Kg Weight net:</p>	<p><b>Confezione Packaging</b></p>	<p>Peso lordo: 4.3 Kg Weight gross:</p>	<p>n. Colli: 1 n. Pack:</p>	<p>Volume m<sup>3</sup>: 0.025 Volume m<sup>3</sup>:</p>

## Cluster 5 Lights Round Cluster Canopy | Rosone Cluster

<p>[RO5]</p> 	<p>Rosone circolare per 5 sospensioni Ceiling bracket for 5 suspensions</p>	<p>bianco opaco 9010 matt white 9010</p>	<p><b>Cluster system</b></p>	<p>154015</p>		
<p>CE </p>		<p>Peso netto: 3.55 Kg Weight net:</p>	<p><b>Confezione Packaging</b></p>	<p>Peso lordo: 4.3 Kg Weight gross:</p>	<p>n. Colli: 1 n. Pack:</p>	<p>Volume m<sup>3</sup>: 0.025 Volume m<sup>3</sup>:</p>

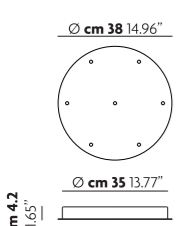
## Cluster 7 Lights Round Cluster Canopy | Rosone Cluster

<p>[RO7]</p> 	<p>Rosone circolare per 7 sospensioni Ceiling bracket for 7 suspensions</p>	<p>bianco opaco 9010 matt white 9010</p>	<p><b>Cluster system</b></p>	<p>154016</p>		
<p>CE </p>		<p>Peso netto: 3.55 Kg Weight net:</p>	<p><b>Confezione Packaging</b></p>	<p>Peso lordo: 4.3 Kg Weight gross:</p>	<p>n. Colli: 1 n. Pack:</p>	<p>Volume m<sup>3</sup>: 0.025 Volume m<sup>3</sup>:</p>

Note | Notes: .....

# CLUSTER system

MODELLO | MODEL      INFO | INFO      COLORE | COLOR      SISTEMA | SYSTEM      CODICE | CODE

## Cluster 14 Lights Round Cluster Canopy | Rosone Cluster

<p>[RO14]</p> 	<p>Rosone circolare per 14 sospensioni Ceiling bracket for 14 suspensions</p>	<p>bianco opaco 9010 matt white 9010</p>	<p><b>Cluster system</b></p>	<p>154017</p>		
<p>CE </p>		<p>Peso netto: 14.14 Kg Weight net:</p>	<p><b>Confezione Packaging</b></p>	<p>Peso lordo: 18.04 Kg Weight gross:</p>	<p>n. Colli: 1 n. Pack:</p>	<p>Volume m<sup>3</sup>: 0.122 Volume m<sup>3</sup>:</p>

## Cluster 24 Lights Round Cluster Canopy | Rosone Cluster

<p>[RO24]</p> 	<p>Rosone circolare per 24 sospensioni Ceiling bracket for 24 suspensions</p>	<p>bianco opaco 9010 matt white 9010</p>	<p><b>Cluster system</b></p>	<p>154025</p>		
<p>CE </p>		<p>Peso netto: 23.5 Kg Weight net:</p>	<p><b>Confezione Packaging</b></p>	<p>Peso lordo: 28.91 Kg Weight gross:</p>	<p>n. Colli: 1 n. Pack:</p>	<p>Volume m<sup>3</sup>: 0.22 Volume m<sup>3</sup>:</p>

## Cluster 36 Lights Round Cluster Canopy | Rosone Cluster

<p>[RO36]</p> 	<p>Rosone circolare per 36 sospensioni Ceiling bracket for 36 suspensions</p>	<p>bianco opaco 9010 matt white 9010</p>	<p><b>Cluster system</b></p>	<p>154018</p>		
<p>CE </p>		<p>Peso netto: 32.7 Kg Weight net:</p>	<p><b>Confezione Packaging</b></p>	<p>Peso lordo: 38.59 Kg Weight gross:</p>	<p>n. Colli: 1 n. Pack:</p>	<p>Volume m<sup>3</sup>: 0.19 Volume m<sup>3</sup>:</p>

Note | Notes: .....

# CLUSTER system

MODELLO | MODEL INFO | INFO COLORE | COLOR SISTEMA | SYSTEM CODICE | CODE

## Cluster 7 Lights Rectangular Cluster Canopy | Rosone Cluster

<p>[RE1]</p>	<p>Rosone rettangolare per 7 sospensioni Rectangular Canopy for 7 suspensions</p>	<p>bianco opaco 9010 matt white 9010</p>	<p><b>Cluster system</b></p>	<p>154019</p>	
<p>CE </p>		<p>Peso netto: 9.89 Kg Weight net:</p>	<p><b>Confezione Packaging</b></p>	<p>Peso lordo: 11.37 Kg Weight gross:</p>	<p>n. Colli: 1 n. Pack: Volume m<sup>3</sup>: 0.052</p>

## Cluster 14 Lights Rectangular Cluster Canopy | Rosone Cluster

<p>[RE2]</p>	<p>Rosone rettangolare per 14 sospensioni Rectangular Canopy for 14 suspensions</p>	<p>bianco opaco 9010 matt white 9010</p>	<p><b>Cluster system</b></p>	<p>154020</p>	
<p>CE </p>		<p>Peso netto: 17.1 Kg Weight net:</p>	<p><b>Confezione Packaging</b></p>	<p>Peso lordo: 20.10 Kg Weight gross:</p>	<p>n. Colli: 1 n. Pack: Volume m<sup>3</sup>: 0.098</p>

## Cluster 28 Lights Rectangular Cluster Canopy | Rosone Cluster

<p>[RE3]</p>	<p>Rosone rettangolare per 28 sospensioni Rectangular Canopy for 28 suspensions</p>	<p>bianco opaco 9010 matt white 9010</p>	<p><b>Cluster system</b></p>	<p>154021</p>	
<p>CE </p>		<p>Peso netto: 31.1 Kg Weight net:</p>	<p><b>Confezione Packaging</b></p>	<p>Peso lordo: 36.39 Kg Weight gross:</p>	<p>n. Colli: 1 n. Pack: Volume m<sup>3</sup>: 0.165</p>

Note | Notes: .....

# RADIAL system

## Decentralization Cylinder | Cilindro

<p>[accessory]</p>	<p>Cilindro di decentramento cavo Wall &amp; Ceiling anchor</p>	<p>trasparente clear</p>	<p><b>Radial system</b></p>	<p>130009</p>	
<p>CE</p>		<p>Peso netto: 0.02 Kg Weight net:</p>	<p><b>Confezione Packaging</b></p>	<p>Peso lordo: 0.08 Kg Weight gross:</p>	<p>n. Colli: 1 n. Pack: Volume m<sup>3</sup>: 0.002</p>

## Radial Single or Double Radial Canopy | Rosone Decentramento

<p>[RS1]</p>	<p>Rosone circolare per lampada singola decentrata o doppia contrapposte Ceiling bracket for single decentralized suspension or double opposed</p>	<p>bianco opaco 9010 matt white 9010</p>	<p><b>Radial system</b></p>	<p>154026</p>	
<p>CE </p>		<p>Peso netto: 0.35 Kg Weight net:</p>	<p><b>Confezione Packaging</b></p>	<p>Peso lordo: 0.41 Kg Weight gross:</p>	<p>n. Colli: 1 n. Pack: Volume m<sup>3</sup>: 0.002</p>

## Radial 12 Lights Round Radial Canopy | Rosone a Raggiera

<p>[RS6]</p>	<p>Rosone circolare massimo 12 sospensioni a raggiera Ceiling bracket max 12 suspensions radially</p>	<p>bianco opaco 9010 matt white 9010</p>	<p><b>Radial system</b></p>	<p>154027</p>	
<p>CE </p>		<p>Peso netto: 1.05 Kg Weight net:</p>	<p><b>Confezione Packaging</b></p>	<p>Peso lordo: 1.41 Kg Weight gross:</p>	<p>n. Colli: 1 n. Pack: Volume m<sup>3</sup>: 0.013</p>

## Radial 28 Lights Round Radial Canopy | Rosone a Raggiera

<p>[RS28]</p>	<p>Rosone circolare massimo 28 sospensioni a raggiera Ceiling bracket max 28 suspensions radially</p>	<p>bianco opaco 9010 matt white 9010</p>	<p><b>Radial system</b></p>	<p>154028</p>	
<p>CE </p>		<p>Peso netto: 3.35 Kg Weight net:</p>	<p><b>Confezione Packaging</b></p>	<p>Peso lordo: 4.19 Kg Weight gross:</p>	<p>n. Colli: 1 n. Pack: Volume m<sup>3</sup>: 0.031</p>





Note | Notes: .....





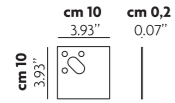

# ACCESSORY

MODELLO | MODEL      INFO | INFO      COLORE | COLOR      SISTEMA | SYSTEM      CODICE | CODE



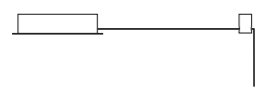

## Back Plate Puzzle Accessory | Accessorio

<p>[P]</p> 	<p>Piastra a muro opzionale per Puzzle e Puzzle Twist parete e plafoniera.</p> <p>Optional backplate for Puzzle and Puzzle Twist Wall and Ceiling</p>	<p> bianco opaco 9016 matt white 9016</p>	<p><b>Puzzle series</b> <b>Puzzle Twist series</b></p>	<p>146013</p>
<p>0,5 m  </p>		<p>Peso netto: 0,07 Kg Weight net:</p>	<p><b>Confezione Packaging</b>      Peso lordo: 0,13 Kg Weight gross:</p>	<p>n. Colli: 1      Volume m³: 0,002 n. Pack:      Volume m³:</p>

## Kit Cable

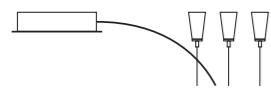
	<p>Decentramento per sospensioni con cavo elettrico portante</p> <p>Decentralization for suspension with single power cable</p>	<p> bianco opaco 9010 matt white 9010</p> <p>and </p> <p> trasparente clear</p>	<p><b>A-Tube series</b> <b>Sugegasa series</b></p>	<p>130010</p>
<p></p>		<p>Peso netto: 0,37 Kg Weight net:</p>	<p><b>Confezione Packaging</b>      Peso lordo: 0,43 Kg Weight gross:</p>	<p>n. Colli: 1      Volume m³: 0,002 n. Pack:      Volume m³:</p>

## Kit Steel

	<p>Decentramento per sospensioni con funi d'acciaio</p> <p>Decentralization for steel cable suspension</p>	<p> bianco opaco 9010 matt white 9010</p> <p>and </p> <p> cromo chrome</p>	<p><b>Kelly series</b> <b>Maggio series</b></p>	<p>130011</p>
<p></p>		<p>Peso netto: 0,5 Kg Weight net:</p>	<p><b>Confezione Packaging</b>      Peso lordo: 0,56 Kg Weight gross:</p>	<p>n. Colli: 1      Volume m³: 0,002 n. Pack:      Volume m³:</p>

[Ex: 1] Kelly Sphere with Kit Steel | Kelly Sphere con Kit Steel

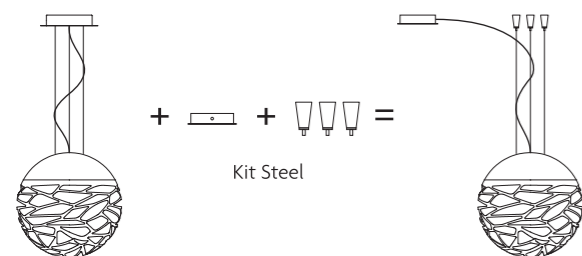

[Ex: 2] A-Tube with Kit Cable | A-Tube con Kit Cable

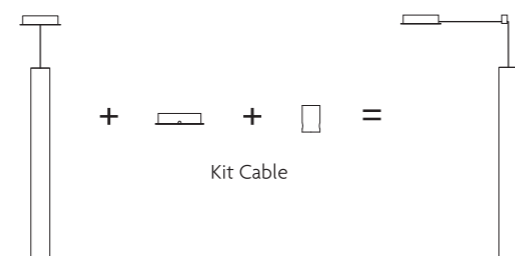

Note | Notes: .....

THE  
LIGHTING  
MAKERS  
2017

## CONDIZIONI GENERALI DI VENDITA



Art. 1 - Premessa - Salvo deroga risultante da apposito accordo scritto tra le parti, ogni compravendita di prodotti di Studio Italia Design S.r.l., P.IVA 02992370276 (di seguito: “SID”) è regolata dalle seguenti Condizioni Generali di Vendita che costituiscono parte essenziale del contratto e che si intendono pertanto accettate dal Compratore ancorché dallo stesso non sottoscritte. Qualsiasi clausola unilateralmente apposta dal Compratore nei documenti da lui sottoscritti e/o nella sua corrispondenza, che sia contraria o comunque in aggiunta alle seguenti condizioni generali od a quelle speciali espressamente approvate per iscritto dal Venditore, si intende come non scritta ed è priva di ogni effetto.

Art. 2 - Perfezionamento della compravendita, quantitativi e prezzi - La compravendita si intende perfezionata con la conferma d'ordine scritta del Venditore anche a mezzo fax e/o posta elettronica o con l'inizio delle consegne per i casi in cui è stata richiesta l'immediata consegna della fornitura anche in presenza di modifiche intervenute e quindi accettate dal cliente. I prezzi concordati si intendono per prodotti consegnati franco stabilimento del Venditore e non comprendono prestazioni ed oneri accessori (quali IVA, imballo speciale, spese di trasporto, di installazione e/o montaggi e così via).

Art. 3 - Consegna, trasferimento del rischio e trasporto - La merce viene consegnata al Compratore presso lo stabilimento del Venditore o in altro sito dallo stesso indicato per iscritto, ed il trasferimento del rischio avviene con la consegna della stessa al primo vettore o al Compratore nelle ipotesi di ritiro della merce da quest'ultimo direttamente eseguita. La merce viaggia sempre a rischio esclusivo del Compratore anche quando il vettore dovesse essere scelto ed incaricato dal Venditore, essendo quest'ultimo liberato da ogni responsabilità con la consegna dei prodotti al vettore, che ad ogni effetto si intende eseguita a mani dallo stesso Compratore. I termini di consegna pattuiti si intendono indicativi. In caso di ritardo nella consegna imputabile al Venditore per un periodo fino a 60 gg il Compratore non ha il diritto di rifiutare la fornitura, né di richiedere la risoluzione del contratto e/o il risarcimento di alcun danno. Se il ritardo nella consegna supera il termine di 60 gg il Compratore ha la facoltà di richiedere – con lettera raccomandata – l'annullamento dell'ordine e la restituzione degli anticipi eventualmente versati. Resta in ogni caso escluso qualsivoglia obbligo del Venditore di risarcimento danni diretti e/o indiretti di qualsiasi natura e per qualsiasi ragione, in dipendenza del ritardo ovvero della mancata esecuzione della fornitura.

Art. 4 - Riserva di proprietà - Il Compratore acquista la proprietà della merce solo con il pagamento integrale del prezzo fatturato delle forniture ma ne assume i rischi dal momento della consegna.

Art. 5 - Caratteristiche dei prodotti e condizioni di utilizzo – Salvo diverso ed espresso accordo scritto tra le parti, i parametri funzionali dei prodotti sono quelli espressi comunicati o comunque risultanti nei disegni e specifiche tecniche del Venditore se esistenti o su quanto indicato sul sito web [www.studioitaliadesign.com](http://www.studioitaliadesign.com) relativamente ai prodotti. I livelli di qualità dei prodotti forniti sono quelli standard del Venditore, evidenziati nelle relative specifiche o su quanto indicato e desumibile sul sito web del Venditore. E' onere del Compratore individuare e comunicare al Venditore le condizioni di utilizzo dei prodotti prima della relativa definizione tecnica. In mancanza di indicazioni da parte del Compratore il Venditore considera condizioni di utilizzo quelle di prassi dallo stesso considerate o esplicitate nei propri disegni e documentazione tecnica.

Art. 6 - Garanzie - I prodotti forniti sono coperti da garanzia per difetti di materiale e/o fabbricazione per un periodo di 24 mesi dalla consegna se il Compratore risulta essere una persona fisica, diversamente il periodo di garanzia sarà di 12 mesi dalla consegna. Il Venditore sostituisce i prodotti resi in detto periodo di garanzia e riconosciuti difettosi per vizi d'origine ovvero in alternativa ed a sua scelta accredita al Compratore una somma pari al prezzo già fatturato dei prodotti stessi, restando espressamente escluso e rinunciato qualsiasi diverso diritto o pretesa del Compratore anche a titolo di risarcimento danni diretti e/o indiretti o di rimborso di costi dallo stesso sostenuti (quali costo di riprese, di assistenza tecnica, di richiamo, ecc.). Eventuali difettosità o non conformità dei prodotti devono essere segnalate dal Compratore per iscritto al Venditore – a pena di decadenza – entro e non oltre 8 gg dalla data di ricevimento della merce; eventuali difetti occulti devono essere segnalati dal Compratore per iscritto al Venditore – sempre a pena di decadenza- entro 8 gg dalla relativa scoperta. Resta inteso che SID non sarà responsabile per alcun vizio ancorché occulto, comunicato per iscritto, oltre 24 mesi dalla consegna della merce. La garanzia non opera ove i difetti rilevati siano imputabili a negligenza del Compratore e/o ad impiego dei prodotti non conforme con le informazioni e le spiegazioni in ogni caso fornite dal Venditore, alle prescrizioni tecniche, ad errata progettazione, applicazione, montaggio o fabbricazione delle strutture ove sono installati, ad errata manutenzione operata da personale non autorizzato, a pulizia impropria in quanto effettuata con modalità o materiali non idonei, ad errato magazzinaggio, movimentazione e trasporto, ad uso improprio od incauto, anche in caso di impianto elettrico e portata dello stesso non idonea, ovvero a circostanze che comunque non possono ricollegarsi a difettosità di produzione da parte del Venditore. Ogni singolo prodotto SID è conforme alla marcatura richiesta dalla Comunità Europea con la direttiva 93/68 (ampliamento della direttiva 73/23) per confermare con una marcatura riconosciuta in tutta Europa, che le lampade sono state sottoposte alle prove di sicurezza elettrica richieste dalle norme Europee EN-60598-1-2 II ed. + CEI EN 60598-1 IV ed. corrispondenti norme italiane CEI 34-21 + CEI 34-23, norme per la sicurezza elettrica a cui fanno riferimento tutti gli istituti, compreso l'IMQ. I prodotti indicati con il marchio UL e/o ETL sono conformi alla normativa UL 1598/CAN/USA C22.2 No.250.0 o UL 153.

Art. 7 - Obblighi del Compratore - Il Compratore è tenuto a prendere immediatamente in consegna i prodotti affidati dal Venditore al vettore, ovvero – se diversamente concordato – a puntualmente ritirarli presso lo stabilimento del Venditore alla data di comunicazione di merce pronta che potrà avvenire con ogni mezzo da parte del Venditore. Ove il Compratore ritardi il ritiro dei prodotti per un periodo superiore a 10 gg, oltre al pagamento del prezzo deve corrispondere al Venditore un adeguato compenso pari al 2% al giorno dell'importo fatturato per il magazzino degli stessi. Il Compratore deve effettuare i pagamenti normalmente, con le modalità e nei termini precisati in fattura. Sui ritardati pagamenti decorreranno, di pieno diritto e senza necessità di costituzione in mora, gli interessi di cui al D.lgs. n. 231/2002. In caso di ritardo dei pagamenti il Venditore ha diritto a sospendere immediatamente ogni fornitura, anche se dipendente da altri contratti con lo stesso Compratore. Il mancato pagamento nei termini pattuiti comporta in ogni caso la decadenza del Compratore dal beneficio del termine.

Art. 8 - Forza maggiore - Qualora il Venditore sia impossibilitato a rispettare il contratto per cause di forza maggiore o comunque indipendenti dalla sua volontà, i termini previsti per l'esecuzione della fornitura sono automaticamente prorogati per un periodo equivalente al perdurare degli effetti di tali cause. Qualora la causa impeditiva continui per più di 6 mesi entrambe le parti possono chiedere la risoluzione del contratto ed in tal caso il Venditore restituisce al Compratore gli anticipi eventualmente ricevuti, con esclusione di ogni e qualsiasi onere ulteriore a suo carico.

Art. 9 - Contratto – In caso di sottoscrizione di apposito contratto lo stesso con i suoi allegati contiene e riassume le obbligazioni validamente assunte dalle parti e per esse vincolanti. L'adempimento delle parti sarà oggetto di valutazione dell'effettiva esecuzione dei compiti e doveri contrattuali, da effettuarsi in buona fede, onestà e con equità. Le presenti Condizioni Generali di Vendita si applicheranno al contratto salvo deroga risultante da atto scritto o in esso contratto esplicitamente prevista.

Art. 10 - Controversie - Qualora dovesse verificarsi una qualsivoglia controversia avente ad oggetto la formazione, validità, interpretazione, esecuzione, modifica e risoluzione del contratto o delle presenti Condizioni Generali di Vendita, questa sarà risolta secondo i principi e le regole indicate nell'articolo 11 che segue.

Art. 11 - Foro competente e legge applicabile - Foro esclusivamente competente sarà quello di Venezia con esplicita esclusione di ogni altro foro alternativamente competente, e la legge applicabile quella italiana.

Art. 12 - Sito Web - Le presenti Condizioni Generali di Vendita, sono quelle risultanti sul sito web [www.studioitaliadesign.com](http://www.studioitaliadesign.com) e sono stampabili e riproducibili su supporto cartaceo. SID si impegna ad aggiornare il sito web [www.studioitaliadesign.com](http://www.studioitaliadesign.com) mediante la pubblicazione sullo stesso della versione di Condizioni Generali di Vendita di volta in volta modificata.

## GENERAL CONDITIONS OF SALE



Art. 1 – Recital – Unless otherwise provided for in a separate written agreement between the parties, every sale of products of Studio Italia Design S.r.l., VAT 02992370276 (hereinafter, “SID”) is governed by the following General Conditions of Sale that must be considered as an essential part of this agreement and shall be deemed to have been accepted by the Buyer even though the latter has not signed them. Any clause unilaterally added by the Buyer in the documentation signed by it and/or in its correspondence, being against or in any case in addition to the general conditions or to those specific expressly approved in writing by the Seller, shall be deemed as not written and shall be of no effect.

Art. 2 - Completion of the sale, quantities and prices - The sale is deemed to be completed once the Seller gives the written order confirmation also by fax and/or email or when deliveries are commenced in cases where the immediate delivery of the supply is requested, also in consideration of changes occurred and then accepted by the customer. The prices agreed are understood for products delivered ex works of the Seller and do not include services and accessory charges (such as VAT, special packaging, transport and installation costs, and/or assemblages and so on).

Art. 3 - Delivery, risk transfer and transport - Products are delivered to the Buyer at the Seller's plant or at another place indicated in writing by the Seller, and the risk transfer takes place with the delivery of the goods to the first carrier or Buyer in the events of collection of goods directly carried out by the latter. The products always travel at the Buyer's sole risk also when the carrier is selected and appointed by the Seller, being the latter freed from all responsibilities after having delivered the products to the carrier, this delivery is deemed to all effects being carried out directly by the said Buyer. The delivery terms agreed are to be understood as indicative. If the Seller is responsible for delay of delivery for a period of up to 60 days, the Buyer is not entitled either to refuse the supply or to request the termination of the agreement and/or the compensation for any damages. If the delay in delivery exceeds 60 days, the Buyer is entitled to request – by registered letter- the cancellation of the order and the reimbursement of the advances if paid. In any event, the Seller shall not be liable for and/or direct and indirect damages of any nature and for any reason due to the delay or the failure to carry out the supply.

Art. 4 - Reservation of title - The Buyer acquires property rights over the goods with the full payment of the price invoiced of the supplies but it takes the risks thereof as of the delivery.

Art. 5 - Products features and conditions of use – Unless otherwise expressly agreed in writing by the parties, the conditions for using of the products are those communicated or in any case resulting from the drawings and technical specifications of the Seller, if any, or as described in the website [www.studioitaliadesign.com](http://www.studioitaliadesign.com) in relation to products. The quality levels of products are the standard quality levels of the Sellers, indicated in the relevant specifications as described on the Seller's website. It is always the Buyer's responsibility to identify and notify the Seller of the conditions of use of products before technically defining them. Failing any particular instructions from the Buyer, the Seller considers as usual conditions of use those it considered or described in its designs and technical documentation.

Art. 6 - Warranties - The products delivered are covered by a warranty for defects in material and manufacture for a period of 24 months as of the delivery if the Buyer is a natural person, otherwise the warranty period will be of 12 months as of the delivery. The Seller shall replace the products delivered in this warranty period being faulty due to factory defects or in alternative, at its discretion, pay the Buyer an amount equal to the price already invoiced of the said products, being expressly excluded and waived any other right or claim by the Buyer also as compensation for direct and/or indirect damages or cost repayment borne by it (such as recovery, technical assistance, recalling costs, etc.). Any defectiveness or non-compliance of products shall be reported by the Buyer by writing to the Seller – in order to be valid – within 8 days from receipt of goods; any hidden defects shall be reported by the Buyer by writing to the Seller – always in order to be valid - within 8 days as of the relevant discovery. It being understood that SID will not be responsible for any defect even though hidden, being notified in writing, after 24 months of the delivery of goods. The warranty does not apply where the defects identified are due to the Buyer's negligence and/or to the use of products being not compliant with the information and explanations in any case gave by the Seller, technical provisions, to incorrect design, application, assembly or manufacture of the facilities in which they are installed, to incorrect maintenance carried out by unauthorized personnel, to improper cleaning since it is made with materials and manners being not suitable, to incorrect storage, handling and transport, to improper or imprudent use, also in the event of electrical system and its capacity being not suitable, or to circumstances that in any case cannot be related to the production defectiveness by the Seller. Every single product of SID corresponds to the mark laid down by the European Community with Directive 93/68 (extension of Directive 73/23) to confirm, with a mark recognized all over Europe, that the lights have undergone the electrical safety test required by European standards EN-60598-1-2 II ed. + CEI EN 60598-1 IV ed. corresponding to Italian standards CEI 34-21 + CEI 34-23, electrical safety standards referred to by all institutions, including the IMQ. The products indicated with the logo UL and/or ETL corresponds to the standards UL 1598/CAN/USA C22.2 No.250.0 o UL 153.

Art. 7 - Buyer's Obligations - The Buyer is required to immediately take delivery of the goods given by the Seller to the carrier, or – where otherwise agreed – to timely collect them at the Seller's plant on the date on which the Seller communicates, by any means, that the goods are ready. Where the Buyer delays the collection of the production for a period exceeding 10 days, in addition to the payment of price it shall pay the Seller a proper compensation equal to 2% per day of the price invoiced for storing such products. The Buyer shall carry out the payments normally, in accordance with the terms and conditions specified in the invoice. For late payments it will be accrued by default without need of further notification interest under Legislative Decree no. 231/2002. In the event of payment delays, the Seller is entitled to immediately suspend any supply, even though it has concluded other agreements with the same Buyer. The failure to pay within the terms agreed will cause in any event the loss of favourable terms for the Buyer.

Art. 8 - Force majeure - If the Seller is unable to comply with the agreement due to force majeure or beyond its control events, the deadlines set for the supply are automatically extended for a period in which these effects continue. Where the obstacle to comply with the agreement is longer than 6 months, both parties may request the termination of the agreement and, in such event, the Seller repay the Buyer the advances received, if any, releasing itself from any additional obligation on it.

Art. 9 - Agreement – In the event of execution of a specific agreement signed by the parties, the said agreement together with its Annexes provides for and summarizes the obligations validly undertaken by the parties and being binding for them. The fulfilment by the parties will be subject to effective evaluation of the actual performance of the contractual tasks and duties to be carried out in good faith, with honesty and fairness. These General Conditions of Sale shall apply to the agreement, unless otherwise provided in writing by the parties or expressly provided in the said agreement.

Art. 10 - Disputes - Any dispute which may arise concerning the signing, validity, interpretation, performance, amendment and termination of the agreement or of these General Conditions of Sale will be settled according to principles and rule set forth in Article 11 below.

Art. 11 - Jurisdiction and Applicable Law - The Court of Venice shall be held exclusively competent, being any other court of competent jurisdiction expressly excluded, and the Italian Law shall be applicable.

Art. 12 - Website - These General Conditions of Sale are those indicated on the website [www.studioitaliadesign.com](http://www.studioitaliadesign.com) and may be printed and reproduced on paper. SID undertakes to update the website [www.studioitaliadesign.com](http://www.studioitaliadesign.com) by publishing on it the version of the General Conditions of Sale as amended from time to time.

THE  
LIGHTING  
MAKERS  
2017

STUDIO  
ITALIA DESIGN  
LIGHTING MAKERS

THE  
LIGHTING  
MAKERS  
2017



STUDIO  
ITALIA DESIGN

LIGHTING MAKERS

Art Direction and set design:  
Raimondo Sandri

Photos:  
Studio Pointer  
Stefano Scatà  
Andrea Pancino

Printer:  
Grafiche Tintoretto

Special thanks to:  
Renzo Tortato  
Loris Casonato  
Gatti VilleVenete Treviso  
Enrico  
Ometto Arredamenti  
Solinfo  
Glamora

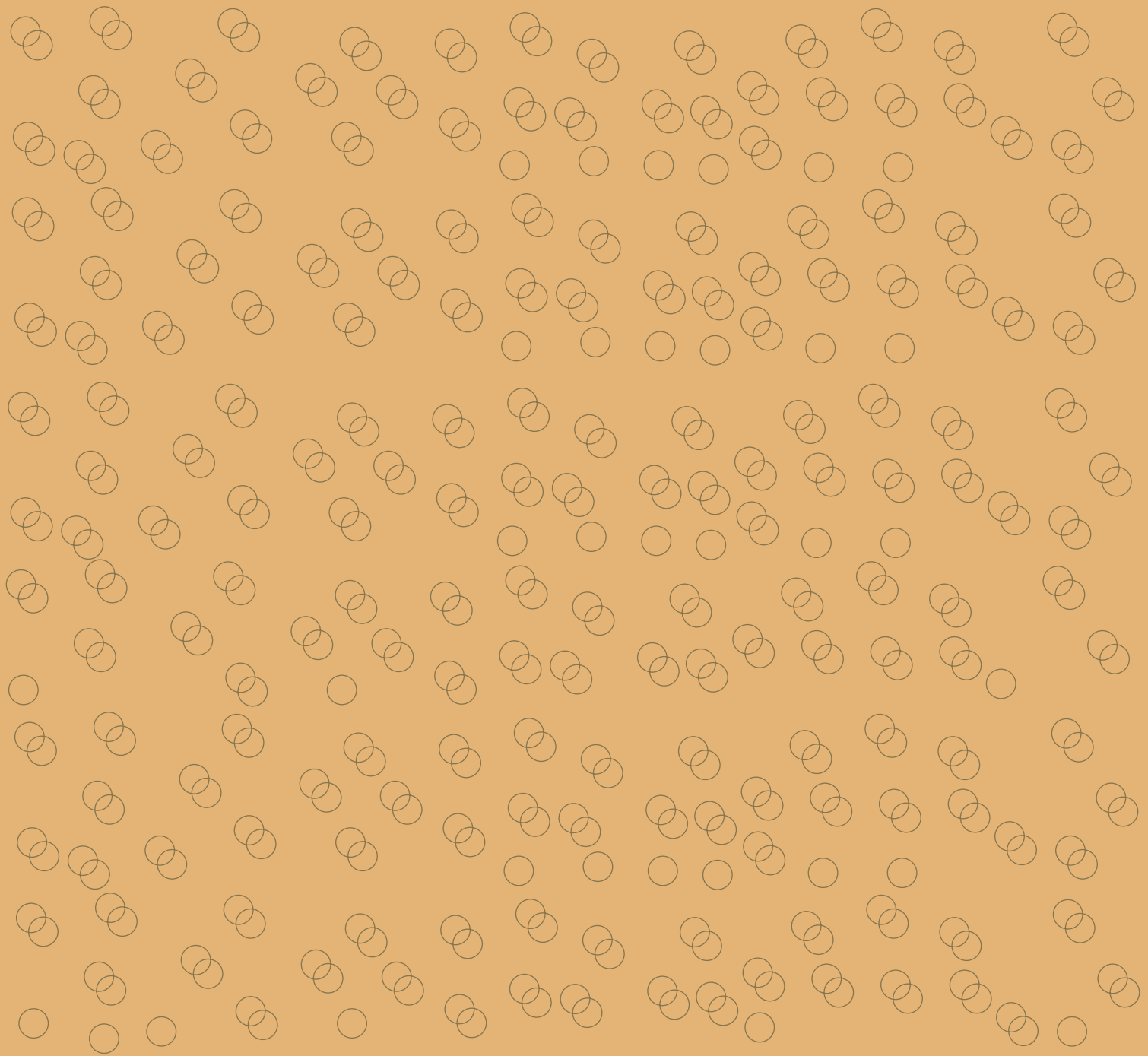

STUDIO ITALIA DESIGN  
Via Pialoi, 32  
30020 Marcon - Venezia - ITALY  
tel +39 041 4569266  
fax +39 041 4567337  
info@studioitaliadesign.com  
www.studioitaliadesign.com