

news

**S** **vistosi** **i**<sup>®</sup>















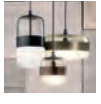







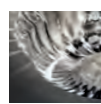

 **Vistosi**<sup>®</sup>

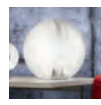
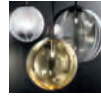



# indice / index

		pagina page
ARIA		42
CRISTALLINA		46
DIADEMA		99
ECOS		96
ESSENCE		78
FUTURA		12
GIOGALI		92
IMPLODE		58
JUBE		22
KIRA		41
MINIGIOGALI		95
MIRAGE		38
MUNEGA		57

		pagina page
NODO		70
NOVECENTO		84
OTO		50
PEGGY		8
POC		82
PUPPET		29
SATA		19
SEMAI		64
STARDUST		72
STARNET		80
STONE		5
SURFACE		60
TUBES		83



# STONE

design Hangar Design Group 2017

Stone è caratterizzata da volumi quasi scolpiti, dove la leggerezza del vetro soffiato si oppone alla solidità di geometrie lineari. In questo contrappunto, tra l'utilizzo di un materiale che naturalmente tende alla forma tonda e un design rigoroso che impone spigoli e linee ortogonali, si esprime l'equilibrio di una composizione luminosa di carattere, inedita.

Sorgente luminosa a LED.

Tonalità del vetro esterno: fumè, cristallo.

Tonalità del vetro interno: bianco.

Parti metalliche: nickel nero.

*Stone is characterized by almost sculptured volumes, where the lightness of blown glass is opposed to the solidity of linear geometries. In this counterpoint, between the use of a material naturally tending to round shapes, and a rigorous design requiring edges and orthogonal lines, the balance of a bright, original composition is expressed. LED light source.*

*Outer glass colour tone: smoky, crystal.*

*Inner glass colour tone: white.*

*Metal parts: nickel black.*









# PEGGY

design Hangar Design Group 2014 - restyling 2017

Il vetro soffiato bianco lavorato a mano insieme al metallo lucido color piombo, interpretano la polarità cromatica del black&white con la leggerezza di un segno razionale ed elegante. Con un'installazione di grande effetto, il lighting system Peggy illumina il Cafè del Peggy Guggenheim Museum di Venezia.

Tonalità del vetro: bianco.

Parti metalliche: nero lucido.

*The white, blown handmade glass together with the glossy black metal, with a lead-effect treatment, interpret the polarity between black&white with the lightness of a rational and elegant design. With an impressive installation the lighting system lights up the Museum Café at Peggy Guggenheim Museum in Venice.*

*Glass colour tone: white.*

*Metal parts: glossy black.*













# FUTURA

design Hangar Design Group 2015

Collezione di lampade in vetro soffiato disponibile in tre esclusive colorazioni abbinata a differenti finiture dell'anello metallico. Il vetro soffiato è in pezzo unico ma la particolare lavorazione lo rende di colore trasparente nella parte superiore e di colore diffusore nella parte inferiore.

Tonalità del vetro: bianco/cristallo, grigio/fumè, topazio/ambra.

Parti metalliche: nero opaco; anello metallico: bronzo, grigio antracite, marrone anticato.

*Collection of lamps in blown glass available in three exclusive colors combined with different finishes of the metal ring. The glass is blown in one piece but the particular handcraft process makes the colour transparent in the upper part and diffuser in the bottom part.*

*Glass colour tone: white/crystal, grey/fumè, topaz/amber.*

*Metal parts: matt black; metal ring in: bronze, anthracite grey, antique brown.*

























# SATA

design Favaretto&Partners 2017

Questo sistema di illuminazione prosegue la riflessione stilistica di Trepai, mettendo ancora più in risalto il legno, sulla cui struttura rigorosa e geometrica poggia il corpo illuminante in vetro soffiato. La collezione è declinata in più versioni per adattarsi a diversi contesti, sia classici sia moderni.

Tonalità del vetro: ambra sfumato, bianco sfumato.

Tonalità del legno: naturale, nero.

*This lighting system carries on with the stylistic reflection of Trepai, and gives even more emphasis to wood, that forms the rigorous and geometric structure where the blown glass light source rests. The collection is available in several versions to suit different contexts, both classic and modern.*

*Glass colour tone: shaded white, shaded amber.*

*Wood colour tone: natural, black.*











# JUBE

design Favaretto&Partners 2017

Essenziale, sinuosa e delicata, nasce dall'unione di due vetri soffiati che, una volta assemblati, danno vita a un gioco di sovrapposizioni e creano un effetto tono su tono dal fascino retrò. Grazie a un potente waterjet, che permette di effettuare sul vetro fori di diametri molto grandi, si integra al meglio la fusione dei due vetri, facendoli apparire come un pezzo unico.

Sorgente luminosa a LED.

Tonalità del vetro superiore: fumè, terra bruciata, verde antico, cristallo.

Tonalità del vetro inferiore: bianco.

Parti metalliche: oro satinato.

*Essential, sinuous and delicate, was born from the union of two blown glasses that, once assembled together, create an overlapping, ton sur ton effect with a retro charm. Thanks to a powerful waterjet, which perforates glass with holes of a very large diameter, the fusion of the glasses is perfectly integrated, so two glasses look like a single piece.*

*LED light source.*

*Top glass colour tone: smoky, burnt sienna, navy green, crystal.*

*Bottom glass colour tone: white.*

*Metal parts: satin gold.*













Jube SP 1G









# PUPPET

design Romani Sacconi Architetti Associati 2015

Collezione di lampade con diffusori in vetro soffiato sfumato e rigato irregolarmente. Le braccia del lampadario sono appese singolarmente a piacere del cliente.

Tonalità del vetro: fumè, topazio, bianco sfumato, cristallo.

Parti metalliche: cromo/cavo grigio, nero/cavo nero.

*Collection of lamps with blown glass diffuser with an original irregularly lined 'dégradé' finish. The arms of the chandelier are hungged individually to customer delight.*

*Glass colour tone: fumè, topaz, shaded white, crystal.*

*Metal parts: chrome/grey cable, black/black cable.*





































# MIRAGE

design Giovanni Barbato 2017

Il vetro soffiato restituisce alla luce il suo ruolo centrale, direzionandola e diffondendola nell'ambiente in modo confortevole, sottolineandone la luminosità.

Sorgente luminosa LED.

Tonalità del vetro: bianco/cristallo, ambra/cristallo, fumè/cristallo.

Parti metalliche: bianco

*The blown glass gives light its central role, by comfortably directing and spreading it in the environment, and emphasizing its brightness.*

*LED lighting source.*

*Glass colour tone: white/crystal, amber/crystal, smoky/crystal.*

*Metal parts: white.*











# KIRA

design Alberto Saggia e Valerio Sommella 2017

Kira è una famiglia di lampade che combina il vetro soffiato con il metallo, generando una serie di apparecchi composti da due metà antitetiche: un diffusore in vetro cristallo, decorato e impreziosito da una ricca texture superficiale, sormontato da un cappello in metallo tornito, dall'aspetto più minimale e pulito. Questa collezione combina forme contemporanee alla preziosità e allo sfarzo luminoso del cristallo dei classici lampadari veneziani.

Tonalità del vetro: cristallo 'baloton'.

Parti metalliche: ottone, bronzo, nero opaco.

*Kira is a collection of lamps combining metal with blown glass. The result is a set of lighting systems composed of two antithetical halves: a diffuser in crystal glass, decorated and embellished with a rich surface texture, topped with a turned metal cap, with a minimal and simple look. This collection combines contemporary forms to the preciousness and brightness of classical Venetian crystal chandeliers.*

*Glass colour tone: 'baloton' crystal.*

*Metal parts: brass, bronze, matt black.*



# ARIA

design Giovanni Barbato 2017

Due vetri semplicemente appoggiati a un anello rendono la montatura elemento significativo e caratterizzante della lampada, valorizzando la leggerezza del vetro. I tagli inclinati dei vetri permettono infinite composizioni.

Tonalità del vetro esterno: cromo, rame, bianco sfumato.

Tonalità del vetro interno: bianco.

Parti metalliche: nickel.

*Two glasses simply fixed on a ring make the frame a significant feature of the lamp and give more value to the lightness of the glass. Sloping glass slides allow infinite compositions.*

*Outer glass colour tone: chrome, copper, shaded white.*

*Inner glass colour tone: white.*

*Metal parts: nickel.*











# CRISTALLINA

design Romani Sacconi Architetti Associati 2017

L'idea guida della collezione si sviluppa attorno a un paralume, caratterizzato dalla bombatura sulla sommità e dalla tecnica dello sfumato nel cristallo, che permette alla luce di irradiarsi e diffondersi in modo confortevole nell'ambiente.

Sorgente luminosa a LED.

Tonalità del vetro: bianco sfumato, nero sfumato, cromo sfumato.

Parti metalliche: bianco.

*The main idea of the collection is built around a lampshade, characterized by the curvature at the top and the sfumato technique of the crystal, which allows light to radiate and spread comfortably in the environment.*

*LED light source.*

*Glass colour tone: shaded white, shaded black, shaded chrome.*

*Metal parts: white.*

















# OTO

design Pio e Tito Tosso 2015

Elementi sferici in vetro soffiato disponibili in 4 misure e due decori, con e senza sorgente luminosa. Il particolare design permette l'installazione verticale di più elementi in vetro ed infinite composizioni a scelta del cliente.

Tonalità del vetro: bianco 'rigadin', cristallo 'rigadin'.  
Parti metalliche: nickel lucido

*Spherical blown glass elements available in four sizes and two decorations, with and without lighting source. The special design allows the installation of more vertical glass element and infinite custom combinations.*

*Glass colour tone: 'rigadin' white, 'rigadin' crystal.  
Metal parts: polished nickel*



























# MUNEGA

design Luciano Vistosi 1978

Collezione di lampade in vetro soffiato e modellato a mano libera per creare una forma iconica di Vistosi.  
Tonalità del vetro: bianco lucido.  
Parti metalliche: bianco

*Collection of blown glass lamps and modelled freehand to create an iconic Vistosi shape.  
Glass colour tone: polished white.  
Metal parts: glossy white.*

# IMPLODE

design Gregorio Spini 2011

Questa linea rappresenta l'illusione di una superficie creata dall'implosione di un volume. Il vetro, grazie alla sua densità, lascia trasparire le gradazioni di strati multipli di cristallo bianco e trasparente.

Tonalità del vetro: bianco lucido.

Parti metalliche: bianco.

*A collection that represents the illusion of a surface created by the implosion of a volume. The glass, due to the thickness, shows a gradation of multiple layers of white and transparent crystal.*

*Glass colour tone: glossy white.*

*Metal parts: white.*







Implode LT 38/16

# SURFACE

design Giovanni Barbato 2017

Surface ridefinisce il concetto di superficie: un'estensione del vetro la cui forma è in continuo mutamento. Generata dall'unione e l'intersezione di due solidi in rotazione, assume figure diverse a seconda del punto di vista, lasciando all'osservatore il compito di interpretarlo e reinterpretarlo volta per volta.

Tonalità interna del vetro: fumè, terra bruciata, verde antico, bianco (esterno sempre bianco).  
Parti metalliche: nickel.

*Surface redefines the concept of surface: an extension of glass whose shape is constantly changing. The light source, which is generated by the union and intersection of two solids of revolution, takes different shapes depending on the observer's point of view, thus letting them interpret it over and over again.*

*Internal glass colour tone: smoky, burnt sienna, navy green, white (outside always white).  
Metal parts: nickel.*













# SEMAI

design Alberto Saggia e Valerio Sommella 2015

Collezione di lampade in vetro soffiato a bocca all'interno di una gabbia di acciaio. La tecnica di soffiaggio libera rende ciascuna lampada sempre diversa.

Tonalità del vetro: bianco lucido.

Parti metalliche: gabbia inox scuro.

*Collection of lamps made of a glass mouth blown into a steel cage. This free blowing technique makes each lamp always different.*

*Glass colour tone: glossy white.*

*Metal parts: cage in dark inox.*



















# NODO

design Pio e Tito Toso 2015

Elemento soffiato e lavorato a mano libera. Disponibile in due dimensioni anche componibili a piacere. Illuminazione direzionale verso il basso e diffusa nell'ambiente.

Tonalità del vetro: bianco.

Parti metalliche: cromo.

*Element freehand blown. Available in two sizes also for custom installations. Directional lighting downward and widespread in the ambient.*

*Glass colour tone: white.*

*Metal parts: chrome.*









# STARDUST

design Francesco Lucchese 2015

Collezioni di lampade con braccia in vetro soffiato e lavorato a mano. Le strutture in metallo nascondono un originale sistema di fissaggio dei bracci e del sistema di cablaggio.

Tonalità del vetro: cristallo rigadin.

Parti metalliche: nickel nero.

*Collections of lamps with arms made of blown and handcrafted crystal glass. The metal frames hide an original fastening system of the arms and of the cabling system.*

*Glass colour tone: 'rigadin' crystal.*

*Metal parts: black nickel.*













5

6







Stardust AP 1



Stardust AP 3

# ESSENCE

design atelier oi' 2015

Collezione di lampade con diffusore in canne di vetro lavorato a mano. La superficie è parzialmente opacizzata da una sabbiatura sfumata. Sorgente luminosa a LED.  
Tonalità del vetro: cristallo sfumato, topazio sfumato.  
Parti metalliche: bronzo chiaro.

*Collection of lamps with diffuser in handmade glass rods. The surface is partially opaque by sandblasting nuanced. LED light source.  
Glass colour tone: dégradé crystal, dégradé topaz.  
Metal parts: light bronze.*









Starnet SP 1



## STARNET

design Gianni Veneziano e Luciana Di Virgilio | Veneziano+Team 2015

Infinite trame di tessuti di cristallo permettono di realizzare le composizioni preferite e di modificarle a proprio piacimento in qualsiasi momento.

Tonalità del vetro: cristallo.

Parti metalliche: cromo.

*Infinite crystal wefts allow to realize the preferred compositions and to change them anytime on request.*

*Glass colour tone: crystal.*

*Metal parts: chrome.*







# POC

design Barbara Maggiolo 2003

L'esclusivo impiego della membrana interna nella collezione Poc genera, come una lente, l'effetto di una sfera composta da due metà. La resa di ogni membrana è diversa, creando per ciascun pezzo dinamiche variazioni di intensità di luce e colore sulla superficie.

Tonalità del vetro: bianco e membrana in cristallo, nero e membrana in cristallo o cristallo e membrana bianca e nera.

Parti metalliche: nichel satinato.

*The spherical glass presents an internal membrane that acts as a lens to create the illusion of being made in two halves and adds a sense of dynamic change of intensity and colour to the surface, that allows the uniqueness of each piece.*

*Glass colour tone: white with crystal membrane, black with crystal membrane or crystal with white and black membrane.*

*Metal parts: satin-finish nickel.*





# TUBES

design Matthias Hickl per Lissoni Associati 2005

Una serie di cinque elementi lineari di diversa lunghezza in vetro soffiato, che si possono usare come singole sospensioni, lampade da tavolo, lampade a soffitto o in combinazioni multiple.

Tonalità del vetro: bianco lucido, fumè semitrasparente.

Parti metalliche: nichel opaco.

*A series of five elements of straight lines in different lengths, made of mouthblown glass and that can be used as standalone pendants, table lamps and ceiling fixtures or for multiple combinations.*

*Glass colour tone: glossy white, smoky.*

*Metal parts: opaque nickel.*



# NOVECENTO

design Romani Saccani Architetti Associati 2013 - restyling 2017

La chiave di lettura della collezione Novecento è la volontà di sintetizzare la tradizione muranese del lampadario, nel suo elemento più riconoscibile: il profilo. Lo riproduce un guscio di cristallo che è il prodotto della rotazione a 360° della silhouette del lampadario, mantenendo così le caratteristiche delle forme originali, e risultando perfetto per atmosfere sia classiche che contemporanee.

Tonalità del vetro: bianco, cristallo rigadin.

Parti metalliche: cromo.

*The idea behind the collection Novecento is to reduce the traditional Murano chandelier to its most recognizable elements, its profile. This shape is then reconstructed in a 360° glass outline, that keeps the same characteristics of the original design and is therefore suitable for both classic and contemporary ambiances.*

*Glass colour tone: white, rigadin crystal.*

*Metal parts: chrome.*













Novecento LT



Novecento PT



















# GIOGALI

design Angelo Mangiarotti 1967

Un sistema decorativo d'illuminazione basato sull'elemento del gancio di cristallo componibile. Disponibile in diversi colori, montabile in versione da tavolo, da soffitto, sospensione, da parete e da terra. Può essere impiegato in grandi lampadari e strutture di qualsiasi dimensione.

Tonalità del vetro: cristallo, bianco, nero, cromo, oro, bronzo o colorato a richiesta.

Parti metalliche: cromo.

*A decorative lighting system based on a single element, the handmade glass link. It is available in different colours, as standard table, ceiling, pendant, wall fixture and floor or that can be arranged to offer chandeliers and structures of any dimension.*

*Glass colour tone: crystal, white, black, chrome, gold, bronze, or custom colour.*

*Metal parts: chrome.*















Minigiogali SP RAI

# MINIGIOGALI

design Angelo Mangiarotti 1967 - restyling 2009

La versione ridotta di Giogali, che permette di impiegare i ganci in cristallo per installazioni a parete di minori dimensioni, standard o su misura.  
Tonalità del vetro: cristallo, bianco, nero, cromo, oro, bronzo o colorato a richiesta.  
Parti metalliche: cromo.

*The small size version that helps to expand the range of Giogali to smaller wall fixtures, both standard and custom made.  
Glass colour tone: crystal, white, black, chrome, gold, bronze or custom colour.  
Metal parts: chrome.*

# ECOS

design Renato Toso, Noti Massari & Ass.ti 2007

Collezione di lampade componibili con anelli di vetro di diversi colori e textures. È una soluzione d'illuminazione che offre grandissima possibilità di personalizzazione in termini di forme e misure.

Tonalità del vetro: bianco, alessandrite 'rigadin', cristallo 'rigadin'.

Parti metalliche: cromo.

*A system made with multiple glass rings, available in different colours and textures that offer a high level of personalization in terms of shape and size.*

*Glass colour tone: white, alexandrite 'rigadin', crystal 'rigadin'.*

*Metal parts: chrome.*













# DIADEMA

design Romani Sacconi Architetti Associati 2005

Diadema è un sistema di illuminazione basato sul singolo elemento della canna in puro vetro. Combinando canne di diverse dimensioni, la luce si riflette e si trasmette in una sensazione di movimento. La montatura metallica permette numerose varianti e ampi margini per versioni su misura, sempre a scomparsa, grazie al sistema di fissaggio ideato appositamente per questo modello. Tonalità del vetro: cristallo, topazio. Parti metalliche: cromo.

*Diadema is a lighting system based on a single element, the rod of pure glass. It takes advantage of the way it reflects and transmits the light, while offering a sense of movement by using rods of different sizes. The metal body allows to offer multiple variations and ample space for custom-made versions with concealed metal body, thanks to the fixing system developed for this collection. Glass colour tone: crystal, topaz. Metal parts: chrome.*







# ARIA

Tonalità del vetro  
Glass colour tone

BC/SF BC/CM BC/RA

Parti metalliche  
Metal parts

NI

E27	1x77W E27
<b>technical data USA &amp; Canada</b>	
E26	1x60W E26

max cm 120  
max 47"  
cm 35  
14"

ARIA SP

# CRISTALLINA

Tonalità del vetro  
Glass colour tone

BC/SF CR/CM NE/SF

Parti metalliche  
Metal parts

BC NE

LED	1x12,5W LED
<b>technical data USA &amp; Canada</b>	
LED	1x12,5W LED

max cm 120  
max 47"  
cm 24  
9"

CRISTALLINA SP

# DIADEMA

Romani Sacconi Architetti Associati 2005

Tonalità del vetro  
Glass colour tone

CR TO

Parti metalliche  
Metal parts

CR

E27	1x77W E27
<b>technical data USA &amp; Canada</b>	
E26	1x60W E26

max cm 300  
max 118"  
cm 35  
14"

DIADEMA SP 30 A

E27	1x77W E27
<b>technical data USA &amp; Canada</b>	
E26	1x60W E26

max cm 120  
max 47"  
cm 35  
14"  
cm 18  
7"

DIADEMA SP 18 A

ALO	1x60W G9
<b>technical data USA &amp; Canada</b>	
ALO	1x60W G9

max cm 120  
max 47"  
cm 35  
14"  
cm 7  
3"

DIADEMA SP 07 A

segue / continues



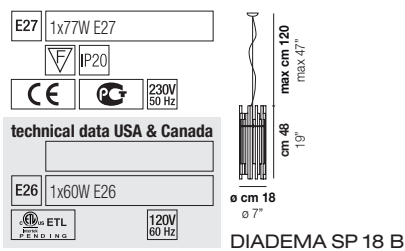

DIADEMA SP 18 B

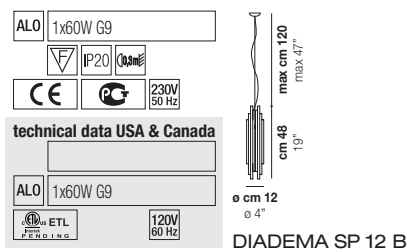

DIADEMA SP 12 B

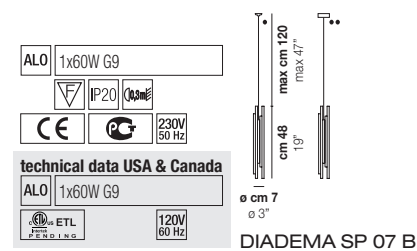

DIADEMA SP 07 B

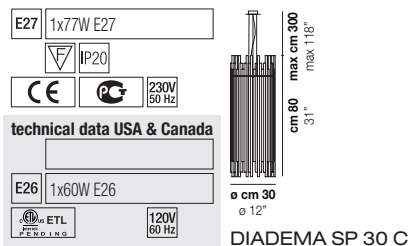

DIADEMA SP 30 C

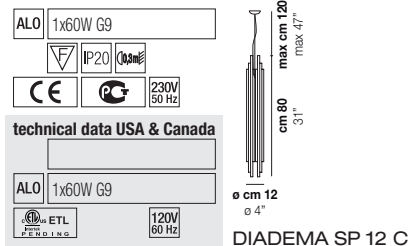

DIADEMA SP 12 C

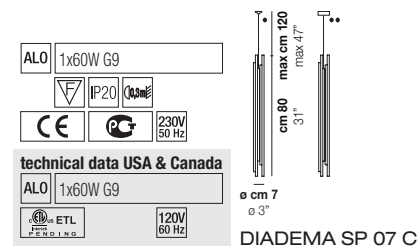

DIADEMA SP 07 C

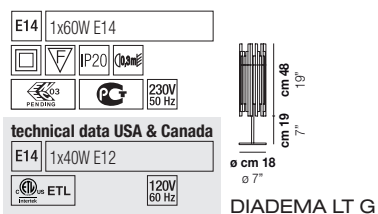

DIADEMA LT G

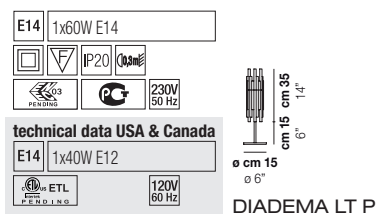

DIADEMA LT P

# ECOS

Renato Toso, Noti Massari & Associati 2007

Tonalità del vetro  
Glass colour tone

- AL
- AR
- BC
- CR/TR
- NE

Parti metalliche  
Metal parts

- CR

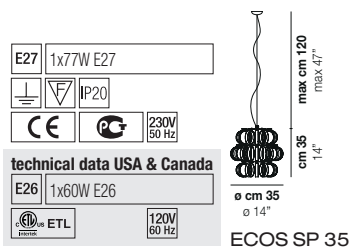

ECOS SP 35

# ESSENCE

atelier oi 2015

Tonalità del vetro  
Glass colour tone

CR/SF TO/SF

Parti metalliche  
Metal parts

AB

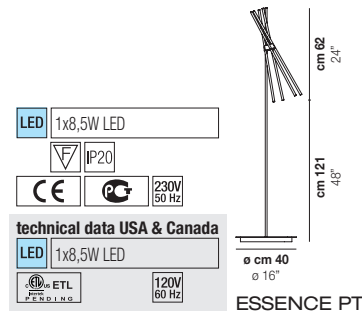
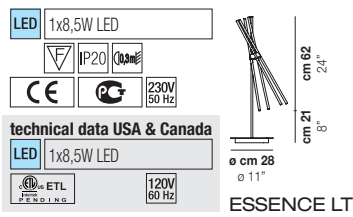
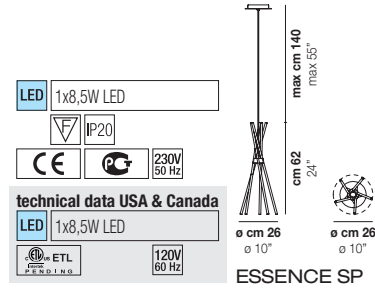
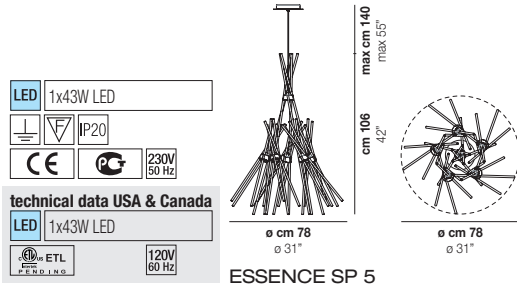

# FUTURA

Hangar Design Group 2015

Tonalità del vetro  
Glass colour tone

BC/CR GR/FU TO/AM

Parti metalliche  
Metal parts

GR MA OT

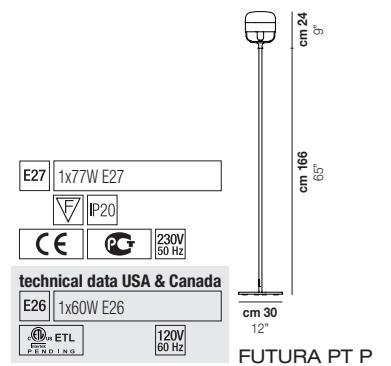
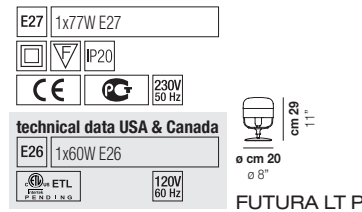
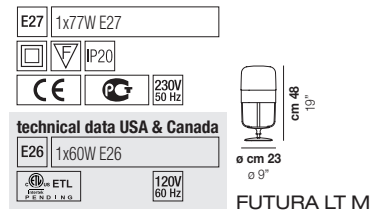
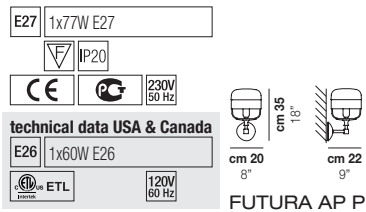
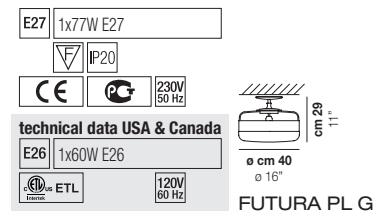
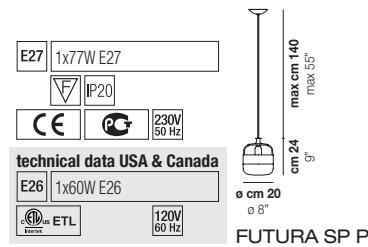
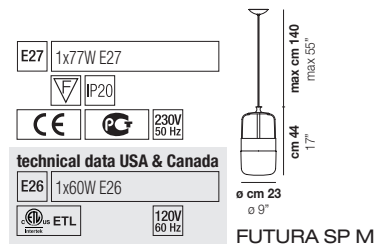
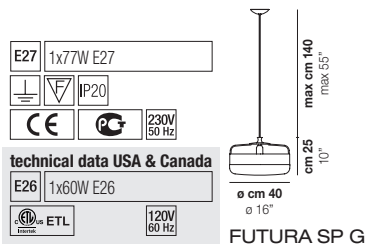



# GIOGALI

Angelo Mangiarotti 1967

Tonalità del vetro  
Glass colour tone

CR/TR CR/FU CR/AM BC NE

Parti metalliche  
Metal parts

CR

E27	1x77W E27
IP20	
CE	230V 50 Hz
<b>technical data USA &amp; Canada</b>	
E26	1x60W E26
ETL	120V 60 Hz

GIOGALI SP JEL

E27	3x77W E27
IP20	
CE	230V 50 Hz
<b>technical data USA &amp; Canada</b>	
E26	3x60W E26
ETL	120V 60 Hz

GIOGALI SP CUB

# MINIGIOGALI

Angelo Mangiarotti 1967 - restyling 2009

Tonalità del vetro  
Glass colour tone

CR/TR CR/FU CR/AM BC NE

Parti metalliche  
Metal parts

CR

ALO	1x60W G9
IP20	
CE	230V 50 Hz
<b>technical data USA &amp; Canada</b>	
ALO	1x60W G9
ETL	120V 60 Hz

MINIGIOGALI SP RAI

ALO	3x60W G9
IP20	
CE	230V 50 Hz
<b>technical data USA &amp; Canada</b>	
ALO	3x60W G9
ETL	120V 60 Hz

MINIGIOGALI SP CLO

E27	3x77W E27
IP20	
CE	230V 50 Hz
<b>technical data USA &amp; Canada</b>	
E26	3x60W E26
ETL	120V 60 Hz

MINIGIOGALI SP CLA

ALO	6x60W G9
IP20	
CE	230V 50 Hz
<b>technical data USA &amp; Canada</b>	
ALO	6x60W G9
ETL	120V 60 Hz

MINIGIOGALI SP CHA

# IMPLODE

Gregorio Spini 2011

Tonalità del vetro  
Glass colour tone

BC/CR

Parti metalliche  
Metal parts

BC

E27	3x77W E27
IP20	
230V 50 Hz	
<b>technical data USA &amp; Canada</b>	
E26	3x60W E26
120V 60 Hz	

IMPLODE LT 38

ALO	1x60W G9
IP20	
230V 50 Hz	
<b>technical data USA &amp; Canada</b>	
ALO	1x60W G9
120V 60 Hz	

IMPLODE LT 16

# JUBE

Tonalità del vetro  
Glass colour tone

CR FU TB VA BC/CR BC/FU BC/TB BC/VA

Parti metalliche  
Metal parts

OS

LED	1x19,5W LED
IP20	
230V 50 Hz	
<b>technical data USA &amp; Canada</b>	
LED	1x19,5W LED
120V 60 Hz	

JUBE SP 1 G

LED	1x19,5W LED
IP20	
230V 50 Hz	
<b>technical data USA &amp; Canada</b>	
LED	1x19,5W LED
120V 60 Hz	

JUBE SP G

LED	1x19,5W LED
IP20	
230V 50 Hz	
<b>technical data USA &amp; Canada</b>	
LED	1x19,5W LED
120V 60 Hz	

JUBE SP 1 P

LED	1x19,5W LED
IP20	
230V 50 Hz	
<b>technical data USA &amp; Canada</b>	
LED	1x19,5W LED
120V 60 Hz	

JUBE SP P



# KIRA

Tonalità del vetro  
Glass colour tone

CR/BT

Parti metalliche  
Metal parts

BV NO OT

E27	1x77W E27
<b>technical data USA &amp; Canada</b>	
E26	1x60W E26

max cm 120  
max 47"  
cm 20  
8"  
ø cm 32  
ø 12"

KIRA SP P

# MIRAGE

Tonalità del vetro  
Glass colour tone

AM BC/CR FU

Parti metalliche  
Metal parts

BC

LED	1x17,5W LED
<b>technical data USA &amp; Canada</b>	
LED	1x17,5W LED

max cm 120  
max 47"  
cm 30  
12"  
ø cm 37  
ø 14"

MIRAGE SP

# MUNEGA

Luciano Vistosi 1978

Tonalità del vetro  
Glass colour tone

BC

Parti metalliche  
Metal parts

NI

E27	1x77W E27
<b>technical data USA &amp; Canada</b>	
E26	1x60W E26

max cm 120  
max 47"  
cm 35  
14"  
cm 48  
19"

MUNEGA SP G

E27	1x77W E27
<b>technical data USA &amp; Canada</b>	
E26	1x60W E26

max cm 120  
max 47"  
cm 27  
11"  
cm 20  
8"

MUNEGA SP P

# NODO

Pio e Tito Toso 2015

Tonalità del vetro  
Glass colour tone

BC

Parti metalliche  
Metal parts

CR

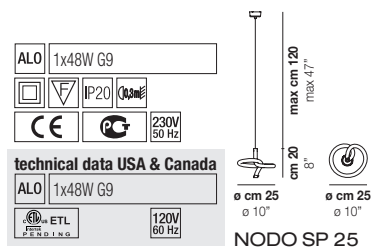
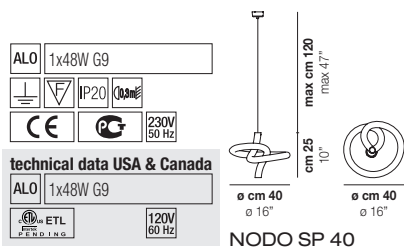

# NOVECENTO

Romani Saccani Architetti Associati 2013

Tonalità del vetro  
Glass colour tone

BC CR/RI

Parti metalliche  
Metal parts

CR

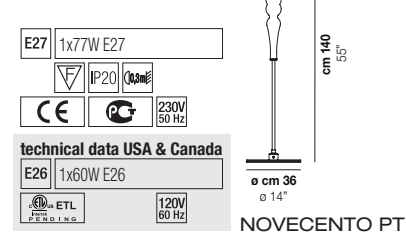
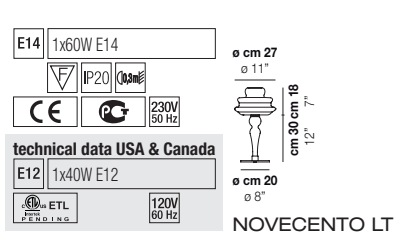
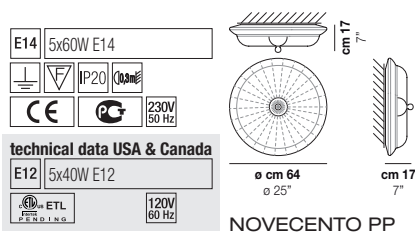
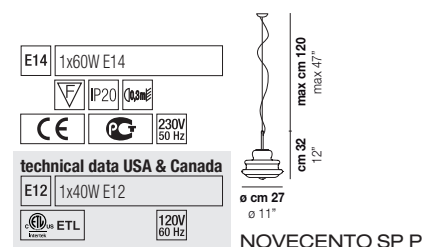
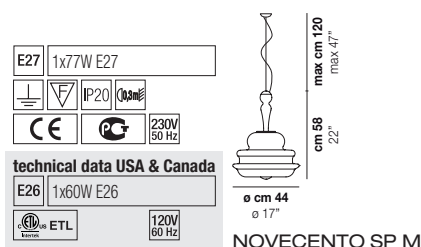
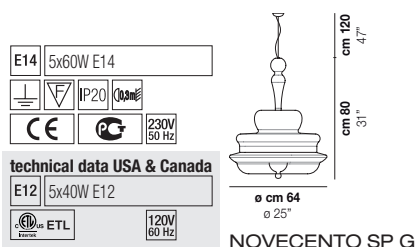



# OTO

Pio e Tito Toso 2015

Tonalità del vetro  
Glass colour tone

BC/RI CR/RI

Parti metalliche  
Metal parts

AS BC NI

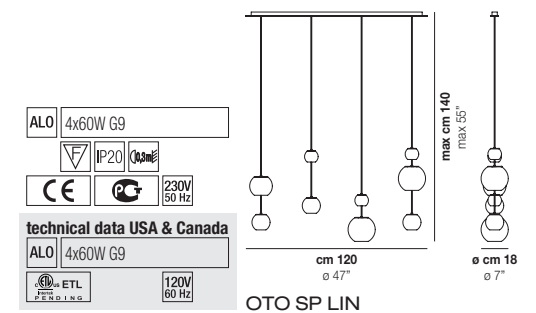
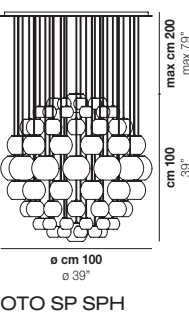
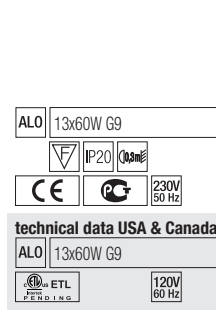
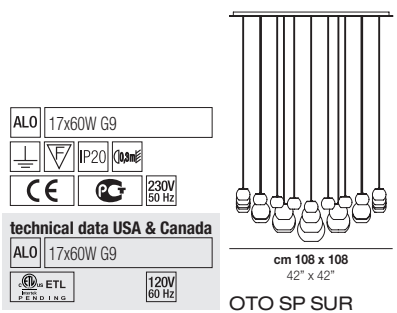
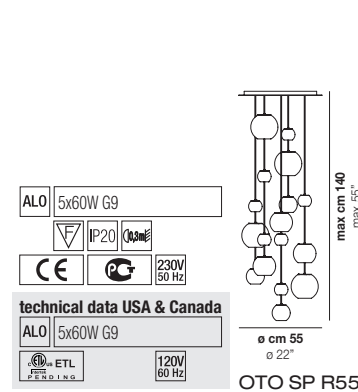
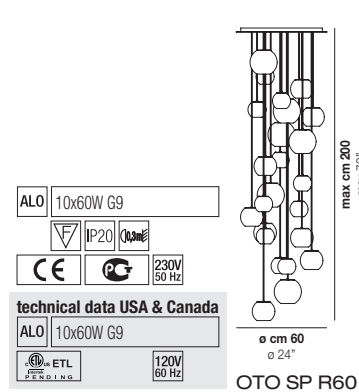
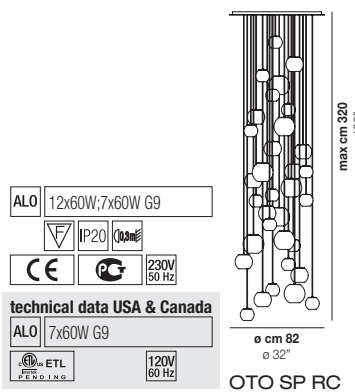
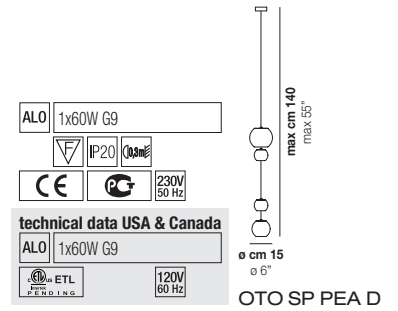
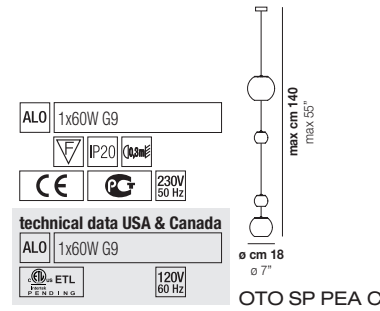
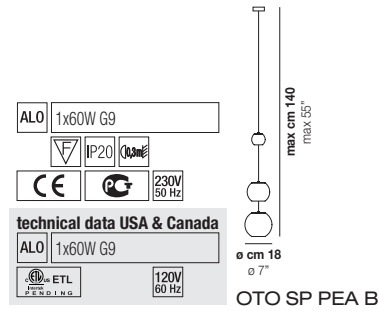
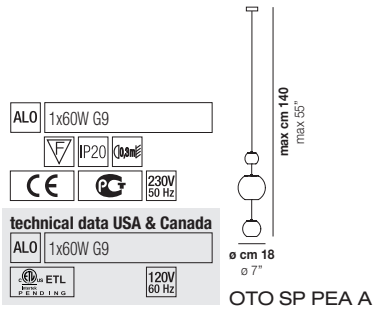
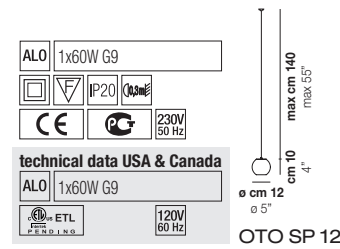
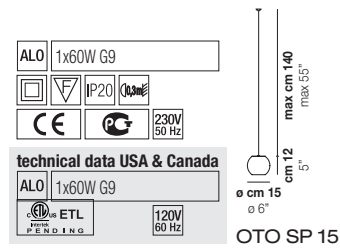
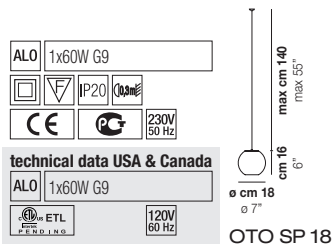

segue / continues

ALO 12x60W G9

IP20

CE

230V  
50 Hz

technical data USA & Canada

ALO 12x60W G9

ETL  
FERRING

120V  
60 Hz

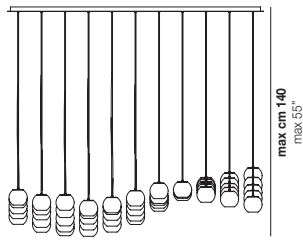

max cm 140  
max 55"

cm 169 x 76  
66" x 30"

OTO SP FC

ALO 12x60W G9

IP20

CE

230V  
50 Hz

technical data USA & Canada

ALO 12x60W G9

ETL  
FERRING

120V  
60 Hz

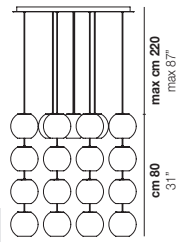

max cm 220  
max 87"

cm 80 x 80  
31" x 31"

OTO SP CUB

ALO 9x60W G9

IP20

CE

230V  
50 Hz

technical data USA & Canada

ALO 9x60W G9

ETL  
FERRING

120V  
60 Hz

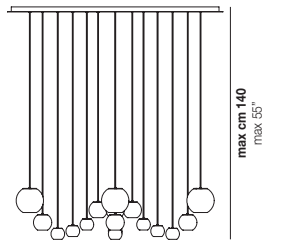

max cm 140  
max 55"

ø cm 140  
ø 55"

OTO SP CHA

# PEGGY

Tonalità del vetro  
Glass colour tone

BC

Parti metalliche  
Metal parts

NE

ALO 9x60W G9

IP20

CE

230V  
50 Hz

technical data USA & Canada

ALO 9x60W G9

ETL  
FERRING

120V  
60 Hz

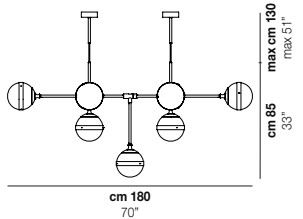

max cm 130  
max 51"

cm 85  
33"

cm 180  
70"

PEGGY SP 9

ALO 1x60W G9

IP20

CE

230V  
50 Hz

technical data USA & Canada

ALO 1x60W G9

ETL  
FERRING

120V  
60 Hz

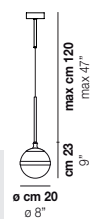

max cm 120  
max 47"

cm 23  
9"

ø cm 20  
ø 8"

PEGGY SP

ALO 1x60W G9

IP20

CE

230V  
50 Hz

technical data USA & Canada

ALO 1x60W G9

ETL  
FERRING

120V  
60 Hz

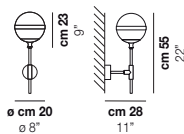

cm 23  
9"

cm 15  
22"

ø cm 20  
ø 8"

cm 28  
11"

PEGGY AP



# POC

Barbara Maggiolo 2003

Tonalità del vetro  
Glass colour tone

CR/BC CR/BN

Parti metalliche  
Metal parts

NI

ALO	1x60W G9
	IP20
	CE
	230V 50 Hz
<b>technical data USA &amp; Canada</b>	
ALO	1x60W G9
	ETL 120V 60 Hz



POC LT 35

ALO	1x60W G9
	IP20
	CE
	230V 50 Hz
<b>technical data USA &amp; Canada</b>	
ALO	1x60W G9
	ETL 120V 60 Hz

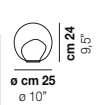

POC LT 25

# PUPPET

Romani Saccani Architetti Associati 2015

Tonalità del vetro  
Glass colour tone

BC/SF CR FU TO

Parti metalliche  
Metal parts

C/G N/N

ALO	6x60W G9
	IP20
	CE
	230V 50 Hz
<b>technical data USA &amp; Canada</b>	
ALO	6x60W G9
	ETL 120V 60 Hz

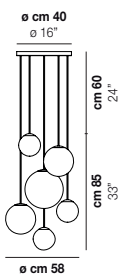

PUPPET SP R6

ALO	3x60W G9
	IP20
	CE
	230V 50 Hz
<b>technical data USA &amp; Canada</b>	
ALO	3x60W G9
	ETL 120V 60 Hz

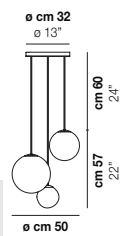

PUPPET SP R3

ALO	24x60W G9
	IP20
	CE
	230V 50 Hz
<b>technical data USA &amp; Canada</b>	
ALO	24x60W G9
	ETL 120V 60 Hz

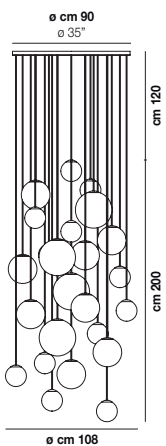

PUPPET SP R24

ALO	12x60W G9
	IP20
	CE
	230V 50 Hz
<b>technical data USA &amp; Canada</b>	
ALO	12x60W G9
	ETL 120V 60 Hz

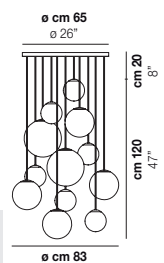

PUPPET SP R12

segue / continues

ALO 9x60W G9

IP20

CE

230V 50 Hz

technical data USA & Canada

ALO 9x60W G9

ETL PERDING

120V 60 Hz

PUPPET SP L9

ALO 6x60W G9

IP20

CE

230V 50 Hz

technical data USA & Canada

ALO 6x60W G9

ETL PERDING

120V 60 Hz

PUPPET SP L6

ALO 1x60W G9

IP20

CE

230V 50 Hz

technical data USA & Canada

ALO 1x60W G9

ETL PERDING

120V 60 Hz

PUPPET SP G

ALO 1x60W G9

IP20

CE

230V 50 Hz

technical data USA & Canada

ALO 1x60W G9

ETL PERDING

120V 60 Hz

PUPPET SP M

ALO 1x60W G9

IP20

CE

230V 50 Hz

technical data USA & Canada

ALO 1x60W G9

ETL PERDING

120V 60 Hz

PUPPET SP P

ALO 1x60W G9

IP20

CE

230V 50 Hz

technical data USA & Canada

ALO 1x60W G9

ETL PERDING

120V 60 Hz

PUPPET SP D26 P

ALO 1x60W G9

IP20

CE

230V 50 Hz

technical data USA & Canada

ALO 1x60W G9

ETL PERDING

120V 60 Hz

PUPPET SP D20 P

ALO 1x60W G9

IP20

CE

230V 50 Hz

technical data USA & Canada

ALO 1x60W G9

ETL PERDING

120V 60 Hz

PUPPET SP D14 P

ALO 1x60W G9

IP20

CE

230V 50 Hz

technical data USA & Canada

ALO 1x60W G9

ETL PERDING

120V 60 Hz

PUPPET AP P

ALO 1x60W G9

IP20

CE

230V 50 Hz

technical data USA & Canada

ALO 1x60W G9

ETL PERDING

120V 60 Hz

PUPPET LT P

ALO 6x60W G9

IP20

CE

230V 50 Hz

technical data USA & Canada

ALO 6x60W G9

ETL PERDING

120V 60 Hz

PUPPET SP 6 P

ALO 12x60W G9

IP20

CE

230V 50 Hz

technical data USA & Canada

ALO 12x60W G9

ETL PERDING

120V 60 Hz

PUPPET SP 12 P

ALO 18x60W G9

IP20

CE

230V 50 Hz

technical data USA & Canada

ALO 18x40W G9

ETL PERDING

120V 60 Hz

PUPPET SP 18 P

segue / continues



ALO 36x40W G9

IP20

CE

230V  
50 Hz

**technical data USA & Canada**

ALO 36x25W G9

ETL  
FERRING

120V  
60 Hz

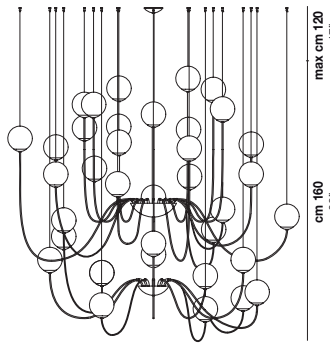

o cm min 150 - max 190  
o min 59" - max 75"

PUPPET SP 36 P

ALO 24x60W G9

IP20

CE

230V  
50 Hz

**technical data USA & Canada**

ALO 24x25W G9

ETL  
FERRING

120V  
60 Hz

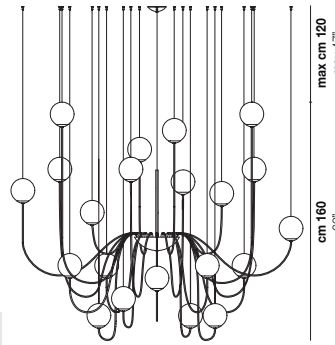

o cm min 150 - max 190  
o min 59" - max 75"

PUPPET SP 24 P

ALO 6x60W G9

IP20

CE

230V  
50 Hz

**technical data USA & Canada**

ALO 6x60W G9

ETL  
FERRING

120V  
60 Hz

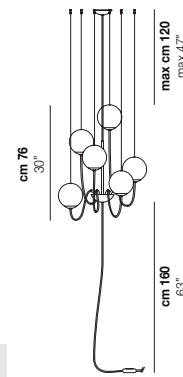

o cm 58  
o 23"

PUPPET PT 6 P

## SATA

Tonalità del vetro  
Glass colour tone

AM/SF BC/SF

Parti metalliche  
Metal parts

LE NE

E27 1x77W E27

IP20

CE

230V  
50 Hz

**technical data USA & Canada**

E26 1x60W E26

ETL  
FERRING

120V  
60 Hz

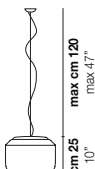

o cm 33  
o 13"

SATA SP

E27 1x77W E27

IP20

CE

230V  
50 Hz

**technical data USA & Canada**

E26 1x60W E26

ETL  
FERRING

120V  
60 Hz

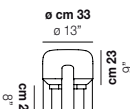

o cm 33  
o 13"

o cm 35  
o 14"

SATA LT

E27 1x77W E27

IP20

CE

230V  
50 Hz

**technical data USA & Canada**

E26 1x60W E26

ETL  
FERRING

120V  
60 Hz

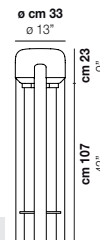

o cm 33  
o 13"

o cm 35  
o 14"

SATA PT

## SEMAI

Alberto Saggia e Valerio Sommella 2015

Tonalità del vetro  
Glass colour tone

BC/LU

Parti metalliche  
Metal parts

BC

E27 2x77W E27

IP20

CE

230V  
50 Hz

**technical data USA & Canada**

E26 2x60W E26

ETL  
FERRING

120V  
60 Hz

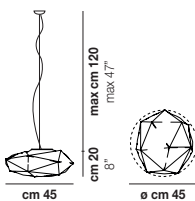

SEMAI SP G

E27 1x77W E27

IP20

CE

230V  
50 Hz

**technical data USA & Canada**

E26 1x60W E26

ETL  
FERRING

120V  
60 Hz

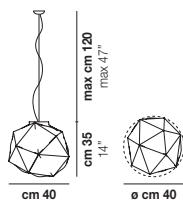

SEMAI SP M

E27 1x77W E27

LED 1x6W LED

IP20

CE

230V  
50 Hz

**technical data USA & Canada**

E26 1x60W E26

ETL  
FERRING

120V  
60 Hz

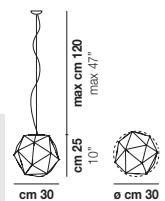

SEMAI SP P

segue / continues

E27	1x77W E27
IP20	
CE	230V 50 Hz

**technical data USA & Canada**

E26	1x60W E26
ETL	120V 60 Hz

SEM AI PL M

E14	1x46W E14
LED	1x6W LED
IP20	
CE	230V 50 Hz

**technical data USA & Canada**

E12	1x40W E12
ETL	120V 60 Hz

SEM AI PL P

E27	2x77W E27
LED	1x12,5W; 1x17,5W LED
LED	Disponibile / Available <b>F</b>
IP20	
CE	230V 50 Hz

**technical data USA & Canada**

E26	2x60W E26
LED	1x17,5W LED
ETL	120V 60 Hz

SEM AI PP G

E14	1x46W E14
IP20	
CE	230V 50 Hz

**technical data USA & Canada**

E12	1x40W E12
ETL	120V 60 Hz

SEM AI LT P

# STARDUST

Francesco Lucchese 2015

Tonalità del vetro  
Glass colour tone

CR/RI

Parti metalliche  
Metal parts

NN

ALO	12x48W G9
IP20	
CE	230V 50 Hz

**technical data USA & Canada**

ALO	12x48W G9
ETL	120V 60 Hz

STARDUST SP R

ALO	8x48W G9
IP20	
CE	230V 50 Hz

**technical data USA & Canada**

ALO	8x48W G9
ETL	120V 60 Hz

STARDUST SP Q

ALO	16x48W G9
IP20	
CE	230V 50 Hz

**technical data USA & Canada**

ALO	16x48W G9
ETL	120V 60 Hz

STARDUST SP DOP

ALO	1x48W G9
IP20	
CE	230V 50 Hz

**technical data USA & Canada**

ALO	1x48W G9
ETL	120V 60 Hz

STARDUST SP

segue / continues



ALO	3x60W G9
IP20	
CE	230V 50 Hz
<b>technical data USA &amp; Canada</b>	
ALO	3x60W G9
ETL	120V 60 Hz

STARLUST AP 3

ALO	1x60W G9
IP20	
CE	230V 50 Hz
<b>technical data USA &amp; Canada</b>	
ALO	1x60W G9
ETL	120V 60 Hz

STARLUST AP 1

ALO	1x48W G9
IP20	
CE	230V 50 Hz
<b>technical data USA &amp; Canada</b>	
ALO	1x48W G9
ETL	120V 60 Hz

STARLUST LT

# STARNET

Gianni Veneziano e Luciana Di Virgilio | Veneziano+Team 2015

Tonalità del vetro  
Glass colour tone

CR/BC

Parti metalliche  
Metal parts

CR

E27	1x77W E27
LED	1x12,5W;1x17,5W LED
IP20	
CE	230V 50 Hz
<b>technical data USA &amp; Canada</b>	
E27	1x77W E27
LED	1x17,5W LED
ETL	120V 60 Hz

STARNET SP 2

E27	1x77W E27
LED	1x12,5W;1x17,5W LED
IP20	
CE	230V 50 Hz
<b>technical data USA &amp; Canada</b>	
E27	1x77W E27
LED	1x17,5W LED
ETL	120V 60 Hz

STARNET SP 1

# STONE

Tonalità del vetro  
Glass colour tone

BC/CR | BC/FU

Parti metalliche  
Metal parts

NN

LED	1x5W LED
IP20	
CE	230V 50 Hz
<b>technical data USA &amp; Canada</b>	
LED	1x5W LED
ETL	120V 60 Hz

STONE SP

# SURFACE

Tonalità del vetro  
Glass colour tone

BC/FU BC BC/TB BC/VA

Parti metalliche  
Metal parts

NI

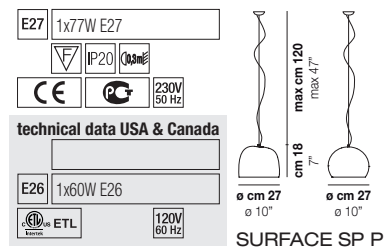
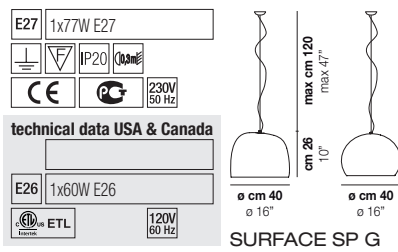

# TUBES

Matthias Hickl per Lissoni Associati 2005

Tonalità del vetro  
Glass colour tone

BC FU

Parti metalliche  
Metal parts

NI

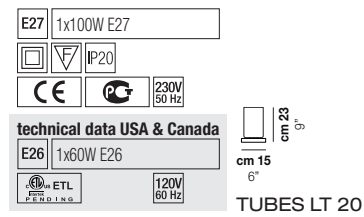
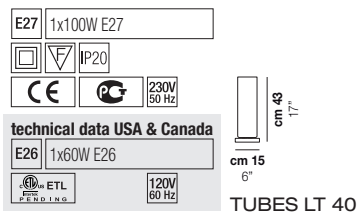





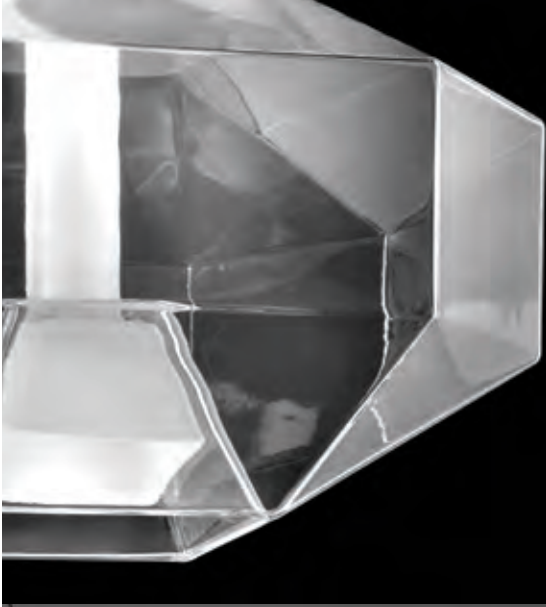





**Fotografia**  
Studio Pointer  
Max Zambelli  
Paolo Utimpergher-design Studio Gobbo (pag. 31)

**Fotolito**  
Studio Pointer

**Stampa**  
Trevisostampa

Edizione n° 1 - Settembre 2017  
Catalogo NEWS (15.16.17)- Rev. n° 07

© Copyright - Vetreria Vistosi s.r.l.  
Proprietà artistica e letteraria  
riservata in tutto il mondo.  
È vietata la riproduzione, anche parziale,  
dei testi e delle fotografie senza autorizzazione.

**Vetreria Vistosi S.r.l.**  
Via Galileo Galilei, 9-9/A-11  
31021 Mogliano Veneto · Treviso · Italy  
Tel. +39 041 5903480 · +39 041 5900170  
Fax +39 041 5900992 · +39 041 5904540  
vistosi@vistosi.it · www.vistosi.it



AZIENDA CERTIFICATA UNI EN ISO 9001:2000





